

**City of Alexandria, Virginia
Park and Recreation Commission**

**REGULAR MEETING
Thursday, May 17, 2012, 7:00 p.m.
Charles Houston Recreation Center
901 Wythe Street, Alexandria, Virginia**

Agenda

- I.** Call to Order by Vice Chair - Robert Moir.
- II.** **Aquatics Facilities Work Session - 7:00 p.m. to 8:00 p.m.**
- III.** Approval of Summary Minutes from April 19, 2012.
- IV.** Division Updates:
 - A. Recreation Programs and Service Update - William Chesley
 - B. Park Operations Report - Jack Browand
 - C. Office of the Arts Update- Cheryl Anne Colton
 - D. Park Planning Updates – Ron Kagawa and Division Team
 - i. Division Updates:
 - Citizen CIP Request for period of November 2011 to April 2012
 - Active Rec CFMP Projects
 - E. Marketing, Public Relations & Special Events – Cheryl Lawrence
- V.** Director’s Report - James Spengler (verbal updates):
 - A. FY 2013 Budget and CIP
 - B. Jones Point Park-Update
 - C. Update on Beauregard Corridor Small Area Plan Letter
- VI.** 2012 CIVIC Awards Subcommittee - Jack Browand
- VII.** Report from Commissioners (verbal updates):
 - A. Waterfront Committee - Gina Baum
 - B. Youth Sport Committee - Bob Moir
 - C. Four Mile Run - Ripley Forbes
 - D. Freedman’s Cemetery - Bob Moir
 - E. ACPS & Capital Improvements - Judy Guse-Noritake
 - F. Jones Point Park Liaison Group - Judy Guse-Noritake
 - G. Community Gardens Policy - Judy Guse-Noritake
 - H. Ft. Ward- Ripley Forbes, Bob Moir
 - I. ACPS School Projects- Judy Guse-Noritake
 - J. Jefferson Houston School - William Cromley
- VIII.** At the close of the meeting, the Commission will take comments on any other topic from the public.
- IX.** Agenda items for June meeting and location.

**City of Alexandria, Virginia
Park and Recreation Commission**

REGULAR MEETING
Thursday, April 19, 2012, 7:00 p.m.
Charles Houston Recreation Center
901 Wythe Street, Alexandria, Virginia

Summary Minutes

Commission Members: Chairperson Judy Guse-Noritake, Gina Baum, Stephen Beggs, Richard Brune, William Cromley, Brian McPherson, Robert Moir, John Sullivan, Mollie Timmons, Caleb Vogt. **Absent:** Robert Moir (Excused), Ripley Forbes (Excused).

RPCA Staff: Director James Spengler; Robin DeShields, Executive Assistant; William Chesley, Deputy Director Recreation Services; Jack Browand, Acting Deputy Director Park Operations; Ron Kagawa, Division Chief Park Planning; Laura Durham, Open Space Planner Park Planning; Dana Wedeles, Park Planner, Judy Lo, Park Planner. **Absent:** Cheryl Lawrence, Acting Director Special Events/Marina, Alisa Carrel, Deputy Director, Office of the Arts, Bethany Carton, Park Planner, David Ghezzi, Architect.

Guest Speakers: Carrie Fesperman Redden, Health Planner with the Alexandria Health Department, and Co-Chair Childhood Obesity Action Network (COAN), Rashad Friday, Department of Transportation and Environmental Services (T&ES).

I. Call to Order by Chair.

The Chair called the meeting to order at 7:00 p.m. and introduced the guest speakers.

II. Approval of Summary Minutes from March 22, 2012, and follow-up of February 16

Approved Minutes:

March 22, 2012: Rich Brune motioned to approve the minutes; the motion was seconded by Mr. Sullivan. All were in favor – the minutes were approved.

February 16, 2012: The Chair entered a clarification and “Comments for the record regarding a portion of the Approved Draft minutes from February 16, 2012”, (copy attached). The minutes will be appended to note the Chair’s corrections/clarifications. Rich Brune motioned to approve the amendment to the minutes, Gina Baum seconded. All were in favor.

III. Alexandria Playspace Assessment by the Childhood Obesity Action Network.

Presentation by Carrie Fesperman Redden – Partnership for a Healthier Alexandria.

Ms. Fesperman Redden, Health Planner with the Alexandria Health Department, and Co-Chair of the Alexandria Childhood Obesity Action Network (A-COAN), gave a presentation on the Alexandria Playspace Assessment (the Assessment). A-COAN is citizen-led coalition with over 100 partners, including many government agencies, non-profits, businesses, faith organizations, and city residents. In Alexandria, 43.5% of children ages 2-5 are overweight or obese, according to a study conducted by Inova Health Systems in 2007. Many of A-COAN’s partners were involved in reviewing and providing oversight to the assessment including RPCA; a multi-disciplinary prospective was taken. Providing better opportunities for healthy play is one of A-COAN’s strategies to reduce childhood obesity. **See Attachments and information sheets.** www.HealthierAlexandria.org/HealthyLifestyes

- **Purpose-** today’s presentation will focus on improving playspaces for children. When they first started looking at childhood obesity, and how to encourage healthy living, a number of focus groups and surveys were held with playgroups and WIC participants. A reoccurring theme was the need for more playspaces and playgrounds for 2-5 year olds in Alexandria. Given that the

City has invested a lot of money in playgrounds, A-COAN felt it was important to explore this further. In February 2012, a Playground Assessment was completed of all playgrounds both public and private. Its goal was to better understand the City's play environment for toddlers and preschoolers, and to provide recommendations for improving the accessibility, quality, and awareness of Alexandria playspaces.

- A-COAN hired consultants; a firm called Design Concepts who has done park and playground planning for several jurisdictions in the metropolitan area, to inventory and assess all of Alexandria's playspaces, provide level of service analyses, conduct focus groups with users and land owner/playground providers, and provide recommendations to improve play for children ages 2-5.
- In concert with the consultants' work, A-COAN launched a Photovoice project with playgroup parents and childcare providers. The coalition gave cameras to 30 participants, many of who did not speak English as their first language, and asked them to photograph what they considered to be the best and worst playgrounds in Alexandria. Over 20 playgrounds were photographed. Photovoice provided insight into key playground features that users considered important and that would be more likely to draw families to the playground, including shade and benches.
- **Photovoice Project Key Findings:** Safety is a concern, with some perception and nervousness about non-caretaker adults and older kids being in areas with younger children. The importance of shade was highlighted over and over again. Parents showed a definite preference for bouncy surfacing, as well as natural play elements. Age-appropriate equipment for children, seating for adults needed, amenities, and indoor play spaces were highly desirable.
- **Inventory and Level of Service Analysis** – Design Concepts assessed and categorized 86 playspaces (public/private, indoor/outdoor) used by all children. All playspaces were mapped and catchment areas were identified. For example, the catchment area for public playspaces is considered the area walkable within 1/3 of a mile, and for private playspaces the area is confined to the parcel or development. The study reviewed 2010 U.S. Census demographic highlights, including data on where the most Alexandria children live including those areas with the highest percentage and highest number of children in the 2-5 year age group. The assessment's recommendations reflect this data and provided maps and level of service analyses for children ages 2-5, as well as children of all ages. As ACPS playgrounds were not open during the school day, they were not included on playground maps for children ages 2-5. Based on the assessment, the consultants made recommendations on how to improve playground accessibility and quality. They also identified several key areas where less quality play was available, including the West End and the northern most part of Arlandria.
- **Focus Groups**- over 70 stakeholders were included in six focus groups held ~~over~~, including meetings with playgroups, parents and childcare providers, city agencies such as Planning and Development, RPCA, and Transportation and Environmental Services, ARHA, Developers, and other direct service providers.

Key Findings (pg. 6) Issues highlighted were the need for improved accessibility and safety (including concerns about risks of having to cross highways to reach playgrounds), and the lack of playspaces near large apartment buildings, particularly in the West End. Participants talked about the desire for different types of play and play equipment, and the importance of amenities, including shade, benches, water fountains and bathrooms. There is a desire for varied play and playgroups to encourage interaction with children. The need for additional indoor play opportunities was also highlighted. Apartment complexes in the West End were particularly isolated from play opportunities where children are not able to walk as easily to parks and play areas. Fesperman Redden said the Assessment identified that there is a perception of inequity and that wealthy children have more places to play than poor

children. This is felt particularly in the West End.

- **Key Recommendations** – Consultants arranged recommendations into three key areas, improving the quality, accessibility, and awareness of playspaces. Consultants were asked to focus recommendations on all playgrounds in the city, not just publicly-owned playgrounds.
 1. **Improve quality** – Focus on improving playspaces in the West End and Arlandria; these are areas that have less access to playgrounds. Overall, try to ensure that the City’s playspaces offer a varied components for play that encourages physical activity, social interaction, intellectual stimulation, and includes natural element. Ensure that all playspaces are appropriate for children aged 2-5. Add amenities that draw families to use the playgrounds, including benches and shade.
 2. **Increase accessibility**- Accessibility is particularly an issue in the West End. It is important to increase walkable access to key playgrounds in that area. Consultants also recommended finding ways to add new spaces at areas where lots of children live. Given that there is not as much public park space in the West, forming creative partnerships could serve to fill this gap. For instance, offer partnering incentives to groups such as homeowners associations and churches that may have available land, or explore the ideas of pop-up and mobile playgrounds, which are growing in popularity.
 3. **Improve awareness of playspaces.** Many playgroup families had trouble finding playgrounds in their neighborhoods. A goal is to inform and improve awareness of playground locations. A website is one idea being considered to serve as a resource to the public. Another idea is to create playgrounds that draw families from across the community, such as destination playgrounds, particularly in areas where there is a perception of inequity. Other ways to highlight locations of playgrounds is to include information about the playgrounds and playgroups in the RPCA Program Guide, and on the Alexandria bike map.

Ms. Fesperman Redden said A-COAN has begun discussing the Assessment with groups like the Park and Recreation Commission, and have formed a Project Play Task Force to study recommendations, and implementation. Several playground initiatives are already underway, such as the ARHA/KaBoom project. The KaBoom playground will be built in Tancil Square in September. A-COAN is also supporting the William Ramsey School PTA.

Questions/Comments:

Q. Chair - What are next steps?

R. Fesperman Redden - The Project Play Task Force is meeting to develop specific recommendations, including developing a website for playground locations, and supporting existing playground efforts, and bringing other groups together to leverage interests and assets. The Task Force is also working with the City’s Department of Planning and Zoning (P&Z), RPCA, and T&ES to see how through City policy to continue to support playgrounds. The Chair agreed a broader effort is needed among City departments and P&Z.

Q. McPherson- When was the Childhood Obesity study completed; asked if 6 to 9 year-olds have the same obesity rate as 2-5 year olds 43.5% - no number is listed for this age group. What is considered “walking distance” to a playground?

R. Fesperman Redden-The Childhood Obesity study by Inova Health Systems was completed in 2007; the obesity rate for children aged 6-9 years of age was 23.5%. Regarding what is considered walking distance, this is debatable. Consultants consider one-third of a mile from home as ‘walking distance’; other experts use one-quarter of a mile. When mapping

catchment areas, there was a cut-off at some highways and major intersections and boundaries that are considered “unwalkable”. P&Z and RPCA provided the major pedestrian hazardous roads.

Q. McPherson- What is considered “private”- churches, private schools, we have a lot of fields but they are locked. Around his neighborhood, some churches have signs that say “play at your own risk”.

R. Fesperman Redden- They have not yet explored the feasibility of using private playgrounds. She was referring to private schools, churches and developers. Regarding playgrounds on church property, this is a gray area. Maryland has done some creative work in partnership with the City in order to take liability off private partners.

Chair - This is a litigious issue. For example, this is why sledding has been prohibited at the Masonic Temple. Caution should be used when using private playground equipment, you could run into problems if the equipment is not kept up to code/standard.

Q. Brune: Is there data that shows how much 2- 5 year olds use play areas? As the City looks at redesigning play areas for this age group, it would be useful to know if the costs are justified. From age 0-2 children are increasingly gaining weight, need to look at root causes.

R. Fesperman Redden - from her assessment, there appears to be a lot of interest in this age group. Regarding justification of costs, you would have to look at the number of children – currently there are over 6000 in this age group and the overall health costs of such a young generation being obese for the rest of their lives.

Chair- There are many factors, including underlying sociological ones that contribute to children becoming overweight or obese. For a long time the Park and Recreation Commission has worked to improve park and recreation facilities in the City, including the West End and Arlandria. The RPCA Needs Assessment, completed in 2011 should be used as a supporting document to the Alexandria Playspace Assessment. It should be understood, that no matter what the Commission proposes for use of public land, there will always be some pushback from some sector of the community and we are always required to go through a public process. In some cases, it may be easier to target private land, particularly in the West End. It comes down to incentives and partnerships, however, the process to get this done on public land is arduous, and might require going through a Development Special Use Permit (DSUP) process, going before the Planning Commission and/or City Council. In contrast it might be possible to find, for example, a church willing to put a playground on their land. The Planning Department may be able to do more to help, in some recent plans there has been some push back on playgrounds. The P&RC has continuously mentioned the need for more visible destination playgrounds, during discussions of the Waterfront Plan. During the Jones Point Park planning process. Making playspaces a part of the City’s overall Planning process is very important. In the Beauregard Corridor Plan, and at Potomac Yards, the Chair has consistently asked for data on the number of new residents expected to move into these areas, as this would require more athletic fields, dog parks, community gardens, and schools. The Commission will need to be more vocal in future about getting more playspaces. The challenge right now for the Department of RPCA is to have sufficient City funding is to keep current playgrounds maintained and with good equipment. Funds for building new playgrounds is currently backlogged years.

- **The Chair-** thanked Ms. Fesperman Redden having brought this work before the Commission; she said the Commission will help where they can. She cautioned that when working with William Ramsey PTA, that Ramsey will have upgrades at some point. Near the Duron/Four Mile Run building the improvements there will not be in the form of playground equipment, but will be big climbing boulders. Playspaces don’t always have to be equipment,

they could be natural areas.

- **Fesperman Redden**- This is part of the education piece, along providing better information on the location of playspaces, but also, broadening the definition of the types of playspaces, including natural play areas.
- **Chair**-the City has completed approximately three pocket parks in the last five years. Pocket parks are small spaces, in urbanized environment, amenities here are limited due to their small space. We need to have playspaces and other places that offer primarily passive uses. Pop up playgrounds are a good idea; incentives from private landowners are needed.

Q. Vogt- What are destination playgrounds? He commented that a website showing the location of playgrounds is a good idea; it could also be used for people to leave comments on, to encourage use.

R. Fesperman Redden- said destination playgrounds are really unique playgrounds that people are willing to travel further distances to get to (vs. pocket parks which are more local). There are destination playgrounds in Arlington and Maryland, where parents take children to for weekend play.

Q. Brune- In the study groups with parents of 2-5 year olds, what number are at home during work hours or cared for at a childcare facility during the day - particularly in the West End? . Parents should be aware that children may not always have access to activities during the day, if cared for at a family daycare provider

R. Fesperman Redden. The numbers are unknown. There are a lot of family day care providers in the West End. A lot of parents can't afford to send children to Day Care Centers.

Baum- said there are a limited number of Day Care Centers in the West End, there are more independent providers. Regarding the website, it would be great if it popped up with a map that would show the locations and information on particular parks.

Chair- City has this information for the public parks but not the private ones.

Fesperman Redden – A-COAN brings together many different groups. The playground website would probably not be a City website, but could link.

Q. Beggs- Is the information updated regularly and does the age range change?

R. Fesperman Redden- This would be a good idea. However, with the Photovoice project, the group is mostly word-of-mouth. They could go back to playgroups.

The Chair thanked Ms. Fesperman Redden for the presentation and asked her to stay in touch with the Commission.

IV. Aquatics Facilities Study briefing. Public Meeting and Presentation to be held on April 25, 2012.

- **See Staff Report/Memo**- Laura Durham, Open Space Coordinator gave an update on the Aquatics Facility Study.
- **Background**: The City currently operates and maintains a municipal outdoor aquatic program that includes seven (7) aquatic facilities at the following sites: Chinquapin, Charles Houston, Old Town, Warwick Village, Nannie J. Lee, Nicholas Colosanto, and John Ewald. Of these pools, Nannie J. Lee and Nicholas Colosanto are currently closed due to budget reductions and the pool at Ewald is proposed to be closed in the FY2013 budget. Chinquapin is the only indoor facility; however, it was not constructed in a manner that can

accommodate sanctioned competitive swimming events. Many of the existing facilities have limited opportunities for expansion and are reaching the end of their functional/physical life expectancy with facilities ages of over 25 to 30 years.

- The professional consulting services of Kimley-Horn/Cousilman-Hunsaker were retained with AMEC Engineering as the Prime Consultant to conduct the Aquatics Facilities Study (the Consultants). This team brings internationally recognized expertise in aquatics facilities.
- A brief summary of the key recommendations is provided in the report, including an estimated cost for each facility (See report). The total cost for implementing all options is estimated to be \$48,823,000, including contingencies. A meeting is scheduled for April 25, 2012, 7:00 p.m. at Lee Center with the Consultants to present their final report and recommendations. The goal is to see how to meet community needs within available funding. **See brief synopsis of study in packet – and key recommendations.**
- Phasing the plan in is recommended by the consultants. Phasing recommendations will be looked with various stakeholder groups. The FY13-22 budget, includes a total of approximately \$9 million for improvements to Chinquapin and spray grounds, however, the recommended rebuilding Chinquapin alone would cost more than \$9 million. Using the budgeted funds to improve other sites is another option. The consultants recommend phasing that would first renovate the Old Town Pool, at a cost of approximately \$5.5 million. The Consultants reviewed all scenarios including costs and revenue. The City Manager and OMB are also reviewing the report. Ms. Durham said the report is a study to provide guidance for the future.
- **Question/Comments:**
 - Cromley- asked what can the \$9 million for Chinquapin be used for; is it roof repair, new HVAC system.
 - Durham- RPCA has been making improvements to Chinquapin. The money would be phased in over years for maintenance to keep the facility operable until it can be replaced.
 - Director Spengler- Currently there is \$9 million in the 10 year CIP. \$3 million is allotted for spray parks, placeholder for outdoor facilities. The Chinquapin estimate looking back several years started out much higher. A Concept Study was completed as part of T.C. Williams rebuilding that was close to \$20 million for renovation of the Recreation Center. A lot is for HVAC replacement, new lockers, equipment is worn out, and infrastructure of building needs to be replaced. The Aquatics study recommends an array of facilities for the Alexandria community. At Chinquapin which is the only indoor facility in Alexandria, the report recommends two options: replacing the current pool with a 25' x 25' meter pool, or 50 meter pool, to include optional leisure elements, renovation of auxiliary rooms for fitness activities.
 - Director- as Ms. Durham mentioned, this study provides some goals. From an engineering, architectural standpoint we have to fill in the gaps.
 - Cromley- commented that both he and his children are swimmers. He said that the Chinquapin facility is beautiful and provides natural light, and that he hopes that they would build a new competitive-size pool before tearing it down. Regarding spray parks, some consider them more of an entertainment type of water activity. The Commission has discussed that the goal should be to focus on life, health, and safety issues. Swimming is an activity that can be done by people of all ages 1-99. We should look at how to serve the most people over the greatest amount of time.

- The Chair- stated that all other park issues need to be considered, along with renovation and/or building new aquatics facilities, balance is needed.
- Durham- the Consultants provided a formula in order to meet broad community needs that includes, having: one indoor pool, one pool in the East End, and one in the West End, where currently there is no public pool.
- Baum- Old Town Pool needs attention because a lot of swim meets are held there.
- Sullivan- asked if the study considered the changing City demographics, and redevelopment in the West End. He stated looking at Pickett, and Van Dorn Streets he doesn't see any new public pools coming on-line there.
- Ms. Durham- responded yes, there is a chapter in the Aquatics Study on demographics, which was completed with inputs from P&Z, ACPS, and Economic Development staff.
- The Chair- said similar to the playground study, there are more private pools in the West End. She would also expect the Beaugard Corridor plan to contain a number of private pools.
- Baum- in the Potomac Yards development, currently being built, there are no public pools.
- Director- confirmed that there are many private pools in the West End. When staff researched information to draft the budget memo regarding proposed closing of Ewald Pool, the data showed that there were 43 private pools within one mile of this pool.
- Chair- when looking at the Beaugard Corridor Plan she assumed there would be workout facilities as part of their planning process so as not to overburden public facilities.

V. Open Space- discussion of issues from April 11th group meeting. Chair Guse-Noritake:

- The Chair reported that after ten years of implementation of the Open Space Plan, the original group is being re-formed. Members will include representatives of the Park and Recreation Commission, Environmental Policy Commission, Planning Commission, and the Archeology/Historic Resources Commission. They are starting to review a list of issues that have come up, and will likely work over several session to craft recommendations. The Open Space Summit that was discussed for May will be deferred if held at all. The group may opt to complete their report and forward it to staff and City Council. The Chair will provide questions for Commission feedback at the next several meetings. This group will look at things like Small Area Plans (SAP) in general, how roof top gardens and fields might count toward open space, if at all. Currently there are no requirements for specific amounts of open space in developments as they come forward.
- Questions include how we protect the financial integrity of the Open Space Fund, particularly in cases like the Beachcomber restaurant that was purchased with open space funds, with the intent that it was to be torn down. If it now stays, will the revenue generated go back into the Open Space Fund? The Group will be meeting soon; the Chair will poll the Commission for comments and questions.

VI. Follow-up Discussion on Beaugard Corridor Small Area Plan Letter: Chair Judy Guse-Noritake:

The Park and Recreation Commission held a public hearing at their regular monthly meeting on March 22 , The Planning Commission will hold a Special Public Hearing on May 3, 2012 on the Plan. The Chair will review the relevant minutes of the hearing, draft a letter reflecting the P&RC's comments and send it to the Planning Commission prior to their hearing. Some key issues, not all inclusive are: 1. Request expenditure of the 1.5

million the City received from the DoD/BRAC mitigation funds for use in acquiring additional open space within the next 3-6 months in the SAP area; 2. Support of the athletic field with artificial turf and lights, positioned as far from the stream valley as possible; 3. The new road planned along the perimeter of Dora Kelley Park needs to be designed as a park road and not a neighborhood road; 4. Support the enlarged park area near the Foster Fairbanks Tract at the intersection of Beauregard St. and Seminary Rd. This park is larger and more publically accessible from the first draft plan the Commission had seen. This is a positive step for the development; 5. Storm-water Detention Pond - the Chair will include language in the letter regarding designing this to be as small as possible. In response to question from McPherson, the Chair explained that as the Plan goes forward the technology will improve, likely reducing the area needed for this Storm Water Detention Pond; 6. Commissioner Sullivan also asked for the roads in this planning area to be designed using pervious pavement. The Chair will include this in the letter. Action- the Chair will review relevant notes and draft a letter reflecting the Park and Recreation Commission's position on the Plan. Ms. Durham suggested that the Chair review the revised draft plan for Beauregard Corridor first.

VII. Division Updates: To View Full Staff Reports go to www.Alexandriava.gov/Recreation/Commission Reports:

- A. **Recreation Programs and Service Update** - William Chesley. See Staff Report. No questions or comments.

- B. **Park Operations Report-** Jack Browand. See Staff Report. No questions. The Chair pointed out that the Four Mile Run Farmers Market will open in May, the site work is proceeding rapidly. Durham said that May 1st is the deadline for the completion of the paving and site work (construction) and that planting will be done over the month of May. The Chair asked that a ribbon cutting and opening be scheduled for June.

- C. **Office of the Arts Update** – report by Alisa Carrel (absent). See Staff Report. The Chair noted that there is a lot going on with the Arts.

- D. **Park Planning Updates** – Ron Kagawa and Division Team.
 - i. Division Updates:
 - **Windmill Hill Park Update-** Dana Wedeles, Park Planner, RPCA, and Rashad Friday of T&ES gave a brief presentation and updates (**See copy of presentation attached**). Wedeles reviewed funding available to implement elements of the Windmill Hill Park Concept Plan as approved by City Council in 2002. The Chair provided background on the project and noted that some of the project's elements involve heavy construction along the waterfront. For example, the plan calls for repair and/or replacement of the seriously deteriorated bulkhead. Over time there have been some complaints from residents and others about the lack of action on implementing the Concept Plan's recommendations. Staff is reviewing the next steps to take. Wedeles said approximately \$1.35 million is available for Windmill Hill Park improvements. Staff has dedicated an estimated \$25,000 to install a safety fence around the bulkhead to bar access to it until repairs can be made. The safety fence was recommended after a March 2012 condition analysis of the deteriorating bulkhead. The fence will improve safety, review of the proposed fence is on the agenda of the Old and Historic District Board of Architectural Review (BAR) meeting scheduled for June. About \$1 million has been set aside for the study and design of a new bulkhead. Funding for the repair work will be available in FY16. The approved Concept Plan elements that could be implemented now with the funding available include family-oriented park furniture, replacement of park perimeter fencing west of Union Street,

playground renovation, and installation of dog park enhancements and interpretive signage at Lee Street and replacing existing signage with way finding signage. Adding landscaping near the dog exercise area is estimated at \$10,000 to \$15,000 and the playground renovation is estimated at \$300,000. These elements would use up large portion of the budget. Two traffic calming projects have been proposed by the Concept Plan -installing speed bumps at the corner of Gibbon and Union Streets and installing a mid-block cross-walk. This area is included within the Union Street Corridor Traffic Mitigation Study that T&ES plans to be released in the fall. In response to a question about whether the Waterfront Commission favors moving ahead with the crosswalk now, Browand said the Commissioners had discussed the plan to defer any changes until after the Union Street Study had been completed and that Councilman Smedberg and other Commissioners had suggested that installing a pedestrian crosswalk now would alert drivers to pedestrians crossing to the park. The Chair said that while this is important, she thought that a lot of money on improvements should not be spent until the Waterfront Plan had been fully adopted. Since 2003 staff has supported the idea of giving the entire street down to the waterfront a different look that says “park” and there are many options for how to do that, for example, putting brick down, painting, etc. When cars drive there they need to understand that there is a park here with people coming and going. She said this street needs to be treated differently and should be integrated into the Union Street Corridor Traffic Study. Cromley said the concern works both ways since if the street area were too park-like; people will be encouraged to cross anywhere.

- Chair- We have some fencing, look at how to open it up and treat area. Simply, installing three crosswalks is not enough. Wedeles said another recommendation from the plan was to include a brick wall on the top walkway. However, staff didn’t feel this was necessary since the walkway was recently renovated and is in good condition. Two other items underway for FY 12 are renovating the basketball court and replacing the fence along basketball court. Wedeles referred Commissioners to the bulkhead pictures to illustrate the extent of the safety and repair issues there. She reviewed a summary of estimated costs for 2012/2013 actions and noted that the balance available to spend is \$335,000.

Comments and Discussion:

- Cromley- commented that he doesn’t support having interpretive signs.
- Q. Sullivan- asked is the cost of the bulkhead or the cost of the bulkhead design.
- R. Director- said estimate came from T&ES. Wedeles-said staff thought it better to over-estimate here.
- **Windmill Hill - Dog Park discussion**- The Chair and Commission members discussed that the safety of pedestrians be considered at the off-leash dog area. It will be important to ensure that dog owners can control their dogs in this area, or alternatively use other fenced in dog parks. The Chair said dog owners may desire a fence, however the plan for this calls for low shrubs. In the past there have been discussions about relocating the dog park away from here for safety reasons, as it is close to the waterfront. McPherson-who is a new Commissioner, questioned whether the dog park should remain in this area at all. The Chair and Baum said that they have brought up the issue of relocating the dog park at Windmill Hill Park in the past. A concern for some Commissioners is that a dog park should not be located this close to the

waterfront for safety reasons, including safety of pets. Baum- who is a dog owner, expressed concern with the proposed location for new furniture/tables planned near the Windmill Hill Park are, as a critical safety issue and asked that the proposed location be reconsidered.

- Wedeles – said if benches were installed now, they could be moved during construction and relocated within the park afterwards.
- Baum- Reported that replacing the bulkhead had been discussed at length at the Waterfront Commission meeting earlier that week and that some Commissioners had hoped that alternatives to the 2002 design might will be considered, noting for example that technology has changed over the years and interest has also grown in having natural shorelines. The idea of breaking up the bulkhead so that its pieces could be used as rip rap in a natural shoreline had been briefly discussed.

Capital Projects Update: See Staff Reports. Kagawa gave updates. See Slide Presentation- Selected Projects Updates April 2012.

- o Four Mile Run Park Expansion- Anticipated completion Phase 1, April 30, plantings to be installed in May.
- o Potomac Yard Park piling- piles have been installed for the belvederes and promenade, 1100 trees total are slated to be installed. The former Simpson restroom building will be replaced with a park manager's office, and new restrooms, etc.
- o Witter Recreation Fields- artificial turf is 75% complete (6.8 acres of turf), on right bathhouse will include control building. The Chair noted that the 85 ft. between the two fields is there to protect a historic cemetery is in between t fields. There is also a walking path around fields. Kagawa- ½ mile field- 10 ft. wide, asphalt.
- o Other- McPherson- asked when the building at Simpson field will be completed. Kagawa- said approximately December.

Capital Facilities Maintenance Projects (CFMP) Recreation Centers –Update March 2012 - See Staff Report.

Capital Project Processes memo dated April 16 to Youth Sports Advisory Board from Ron Kagawa, ASLA LEED AP, Division Chief, RPCA and Monika Szczepaniec, Acting Director of Facilities ACPS.- See Staff Report.

E. Marketing, Public Relations & Special Events – Cheryl Lawrence (absent).

Jack Browand reminded staff that Earth Day is this Saturday April 21, and that the "Spring for Alexandria" community service days are May 4/5. The Chair reminded staff that the City's birthday party is coming up in July, and that it's time to begin working on the Civic Awards Nominations. Mr. Browand will draft and send out the announcement requesting nominations. The P&RC will appoint a sub-committee to work on this project.

VIII. Director's Report - James Spengler: See Staff Report –Item VIII-A.

- A. FY 2013 Budget and CIP Updates- See Staff Report. The Director gave an update on the FY2013 Budget and CIP and RPCA budget memos submitted: The following budget memos can be found on the City website:
[http://alexandriava.gov/budget/info/default.aspx?id=56546:](http://alexandriava.gov/budget/info/default.aspx?id=56546)
#6, Windmill Hill Park; #11, Ewald Pool closure, #16, Holiday Tree display Market Sq.
#21, Jefferson Houston proposal for turf field as part of new school project,
#25, Recreation Fees- proposed increases to begin FY13, #37, Old Town Pool –operation

during construction of Jefferson Houston School, #40 Witter and Hensley Park repair.

- B. Jones Point Park-Update- See Director's Report. The project is proceeding on schedule and will be completed by June 25. The next meeting of the JPP Community Liaison Group will be Saturday April 28, as a construction site tour.
- C. Cell Tower Request Lockett Field-See Director's Report and map of area.
Background: Crown Castle a cellular tower company has a need for a cell phone tower near the intersection of Wheeler Ave. and Duke St. and has submitted a request to the City. The Director and staff have reviewed the request and sites; at this time staff does not recommend conversion of open space for this request. The Chair agreed saying that open space is valuable and that this would set a precedent for other requests. The Director of General Services is preparing a cost estimate for lease of the property. In response to question from Mr. McPherson, the Director said the City does not currently have a policy on this issue. Cromley- asked what is advantage. The Director said the only advantage is accumulated lease payments, which is not substantial. Brune- asked why they aren't looking at Wheeler Ave. as a possible location near Lockett field. The Chair said the other option is for company to find private land to lease.
Action: The Chair said she will put this on the list to ask the Open Space Committee.

IX. Report from Commissioners (verbal updates):

- A. Waterfront Commission - Gina Baum. Reported that the Windmill Hill Concept Plan briefing had also been discussed in the Waterfront Commission that week. (See item D.) A question was raised at its meeting regarding the appropriate procedure to consider a Waterfront Commissioner's proposal that Waterfront Park be renamed John Fitzgerald Park in honor of George Washington's aide. The Director said there is a City Naming Committee. The Chair reviewed the history and background of naming parks. She stated that Pat Troy spoke before the P&RC regarding renaming Waterfront Park to John Fitzgerald Park a number of years ago. The Chair said the Commission's position at that time was not to judge which historical figure deserves to have a park or space named after them. It is her opinion now and was the opinion of the P&RC at the time Troy came to them, that parks and places should be named for and descriptive of their location, not after people. Brune agreed and cited as an example 1 & 7 E. Del Ray Ave. Parks, where a proposal was forwarded to name the park after Kevin Shifflett who is deceased. The proposal was declined by the City Council Naming Committee. He asked also for whom Ewald Pool is named. Baum noted that the Waterfront Plan has a Fitzgerald Park proposed at the foot of King Street.
Action: Gina Baum will send the request to Department of RPCA for follow-up.

Other- Bikeshare Proposal- The Commission had discussed T&ES' proposal to locate a waterfront Bikeshare dock in an area near the Torpedo Factory Art Center, and Chart House restaurant near the waterfront. The Waterfront Commission disagreed with placing a Bikeshare dock there and has asked T&ES to review alternative locations, including near the Beachcomber restaurant, and next to Waterfront Park. The Chair commented that if a Bikeshare station is being considered to be placed at extension of Wales Alley there is already a bike shop there. Baum said the Bikeshare bikes differ in type from the bike shop's those more rented by the bike which offers heavier bikes more suited for traveling long distances along the bike path.
Action: The Chair said the Bikeshare proposal would be an item for the new Waterfront Commission to decide.

- B. Youth Sport Committee - Bob Moir (excused absence) - No report.
- C. Four Mile Run - Ripley Forbes (absent) - No report.
- D. Freedman's Cemetery - Bob Moir (absent). Construction expected to begin May 1st.

- E. **ACPS & Capital Improvements** - Judy Guse-Noritake. The Chair was unable to attend the previous Tuesday's meeting. The site plan has come together/approved.
- F. **Jones Point Park Liaison Group** - Judy Guse-Noritake. No update.
- G. **Community Gardens Policy**: Request for Braddock Station Gardens. The Chair said that she and Laura Durham, Open Space Coordinator, have met and had preliminary discussion with the informal group being assembled to work on developing a garden policy for the City. Durham said the intent is to be able to have a response for new requests for community gardens, and to look at how to promote gardens on private land. RPCA staff reviewed a citizen request for a community garden near the Braddock Rd. Metro Station, and determined that this would not be feasible, due to a lack of irrigation and other uses of the site. Durham- sent a response and indicated group is reviewing garden policy. During this process staff also discovered that placing a community garden on park property in the City may require an SUP. The Chair will take this item up with the Open Space Summit. In the interim, she and Ms. Durham may meet with requestor to update them on status of request.
- H. **Ft. Ward**- Ripley Forbes, Bob Moir, (excused absences) - no report.
- I. **ACPS School Projects**- Judy Guse-Noritake.
- J. **Jefferson Houston School** - William Cromley. It is a huge success to get a turf field approved at Jefferson Houston. The Educational Specifications will drive the design. The Director reported that the other change on project school requires, if the City wants a Head Start class replaced at the school it would cost \$1.5 million. The City Council asked ACPS to do value engineering for classrooms. The Chair- asked the Director RPCA to let her know when the next City/Schools sub-committee meeting will be held. The Chair asked if there were other comments.

Other Discussion:

Francis Hammond Track- Beggs- stated that he feels that installing an asphalt track is substandard; particularly at a proposed estimate of \$200,000 ACPS could possibly include a rubberized surface. There may be ways to value engineer project. He can't recall the cost to install the fence around the field and questions why is there a double fence (one at the field and then another at the site perimeter). Director responded that the issue is whenever the track is open; the field would be open as well.

Beggs- he feels cost is overestimated. There is also a drain around the track, he asked isn't the field itself a drain. The \$200,000 could be spent better. It should cost \$100,000- look at how many kids run track. Expressed concern that there is only one track in the City.

Suggested engineering track now for asphalt allowing for change in the future. There are people who are supportive but there is no money. Discussions are being held with the School Board. Kagawa- one-third of the cost of field is the storm water management system; the cost is folded into field. Currently not in compliance with the Chesapeake Bay Act. In response to the Chair's question on how the Commission could help, Beggs suggested taking it to the School Board members.

Kagawa- they are working with staff.

Action- Beggs will email Mr. Cromley the name of ACPS contacts.

Potomac Yard Metro Update- Baum- asked about the three options for the Metro Station at Potomac Yards, and what is the timing for a decision. Kagawa said process is lengthy going through end of June. There is a meeting tonight for public comments. The Chair said the Commission will weigh in at some point, and asked Mr. Kagawa and RPCA staff to draft a letter for her –to use as a basis to write a Commission comment letter

- X. Public comments on topics not otherwise covered. **None.**

XI. Agenda items for May meeting and location. The Chair noted that she will not be able to attend the next P&RC meeting on May 17. Caleb Vogt noted that he will also be absent, due to taking Advanced Placement Exams at school. The Chair noted that both Caleb Vogt and Mollie Timmons will be graduating from T.C. Williams H.S. in June. She asked that they submit their resignations at June meeting and also asked them for referrals of other youth that may be interested in serving on the Commission. Mollie will attend the University of Washington in Seattle, and Caleb will attend the University of Michigan.

The meeting adjourned: 9:10 p.m.

City of Alexandria, Virginia

MEMORANDUM

DATE: MAY 17, 2012

TO: PARK AND RECREATION COMMISSION MEMBERS

**FROM: WILLIAM CHESLEY, DEPUTY DIRECTOR
RECREATION SERVICES DIVISION**

**SUBJECT: MAY 17, 2012 COMMISSION MEETING ITEM #IV-A
RECREATION PROGRAMS AND SERVICES REPORT**

Youth Activities

- We enrolled and provided services for 499 students in the Titan Lounge after school program. The last day of the program was May 4. The average daily attendance for the program was 125 students. Margaret Orlando and I participated on a planning committee led by ACPS to develop program options for the 2012-2013 program. ACPS submitted a 21st Century Grant this spring seeking funding to offer more program options for students.
- Registration for spring and summer classes and programs is underway. The Department's spring/summer brochure and summer of fun (youth programs) are available (hard copy and online).
- We held the Opening Day Ceremony and Game for the Miracle League on Saturday, April 21 at the Lee Field, Girls Softball Opening Day Ceremony and Game on May 2 at the Cora Kelly Softball Field, and the Annual Cheerleader Invitational at T.C. William HS on April 28. All of the events were well attended. The cheerleader event was attended by 1,500 people. The cheerleader event generated \$3,800 in revenue.
- We will hold the Hershey Track and Field event at T.C. Williams HS on May 19 at noon, a Jump Rope Arts event on May 20 at 3:00 p.m., and Olympic Family Fun Day on June 22, 1p.m. to 6:00 p.m. at Lee Field/Nannie Lee Center.
- We have enrolled 170 children for the Girls Field Hockey Program. We anticipate more enrollment before the program starts. We enrolled 112 girls in year one of the program and more than 200 girls participated in the program last summer.
- Wahoos Swim Team Registration YTD – 60. Registration deadline is May 29. FY 2011-130 total registration.
- We are collaborating with Kelley Cares on their Run/Walk on May 19 at 8:30 a.m. in addition, with ARHA on their Youth Arts Festival at Jefferson-Houston Elementary School on June 9 from noon to 4:00 p.m.
- Charles Houston will work to reschedule the second annual RPCA-ACPS Jazz Concert from June 15, 6:00 pm to 8:00 p.m. to September or October. We agreed it was best to reschedule

because many of the students involved with the middle school bands will be on a field trip on the date of the event. Staff is planning an alternate community event on June 15 to fill that program slot.

- The Alexandria Cooperative Extension/4-H held a 4-H Junior Camp counselor training on April 14 at the Fairlington Community Center. 4-H also exhibited at the Alexandria Earth Day event on April 21 at Ben Brenman Park. On April 24 4-H hosted a recycling fashion show for the students participating in the Henderson Hall USMC event and learned about the value of recycling everyday items. Finally, 4-H participated in the Wired for Wind experiment at the Army National Guard Earth Day event on April 26 where youth learned about how wind turbines create renewable energy and test out a real wind turbine!
- The Recreation Centers displayed projects related to this year's Out of School Time Program theme of "Let's Go Green" at Earth Day on April 21. The display included recycled arts & crafts projects and fashion items from many of the centers, picture boards of gardening projects done at Nannie J. Lee and Mt. Vernon Recreation Centers, and a furniture restoration project done at Power-Up.

Adult Activities

- Virginia Cooperative Extension staff conducted nutrition and other health related workshops for senior adults at recreation centers, schools and the St. Martin Seniors Center.
- The pickle ball program at Charles Houston continues to attract about twenty-five seniors per week.
- The new bowling league implemented this winter included teams of seniors from four of our recreation centers. The program ended in April. We will offer the program again this summer.
- FY 2012 Men's Softball League has 41 teams, up 2 teams from last year. Co-ed Softball is equal at 10 teams this year. Co-ed Soccer at 17 teams, up one team from last year and co-ed volleyball remains the same at 14 teams this year.
- Staff will implement a Kickball and Frisbee Program this spring.
- TR will host an Adult Luau for program participants at Lee Center on May 19, 2:00 p.m.
- The Successful Aging Committee, which includes representatives from RPCA, DCHS, ARHA and the Fire Department, sponsor three senior events throughout the year. The next event for the Successful Aging Committee is the Senior Health Fair held at Lee Center on May 30 in recognition of National Senior Health and Fitness Day.

Recreation Centers

- As of April 30, we have 1,424 children enrolled in our Power-On/Power-Up after school programs. Program enrollment is up by 7.7% this year.
- Mid-school year survey results for the Power-On/Power-Up after school programs reflect an overall 90% satisfaction rate for the program. I will present results for the full school year program in my June report.
- Registration is underway for the summer Power-On and Power-Up programs. The theme of the summer program is "Let's Get F.I.T." F.I.T. stands for Friends in Training Together. Staff set the theme around sports, fitness, competition and teamwork in recognition of the 2012 Summer Olympics.
- Staff is planning the second Annual Olympic Family Fun Day. The event will be held at Lee Center on June 22 from 1-6:00p.m.

- Staff is planning workshops in May and June and a Job Fair in June in partnership with Job Link.

Aquatic Program

- We will implement the new minimum age policy increasing the age from seven to 12 for children to come to outdoor pools without adult supervision. I included a memo on this matter with comparative data from neighboring jurisdictions in my April report.
- Staff will implement a Water Safety Initiative for all children enrolled in RPCA sponsored summer programs beginning with the start of programs on June 25.

Environmental Programs

- Nature Center Director Mark Kelly will implement a “Travelling Nature Center Program” this spring. The goal of the program is to reach more children with nature and environmental education programs by bringing programs to recreation centers and other venues.

Other

- Leslie Clark, Recreation Services Division Chief, is retiring on June 1 after 33 year with the Department. Leslie served in the Division Chief capacity since 2006 and prior to that served as the Department’s Special Events Supervisor.
- GreenPlay, LLC, a Lafayette, Colorado based management-consulting firm that works for Parks, Recreation, Open Space, and related agencies nationwide. The firm will provide consulting services in developing a cost recovery philosophy for all RPCA programs and services.
- I attended the May 9 meeting of the Children, Youth and Families Collaborative Commission (CYFC). The Commission is concerned about reductions in the FY-2013 budget tied to programs with impacts on children, youth and families. The Commission will hold a four-hour retreat on June 13, 5:30 p.m. to 9:30 p.m., at T.C. Williams HS.
- Becky Domokos-Bays of ACPS applied for a grant to offer a pilot supper program at Ramsay. We are supporting the grant submission. As you know, Ramsay is at 85% for free/reduced price school meals. About 400 youth stay after school every day in either after school clubs, tutoring or at the rec. The supper program is a new USDA program for areas like Ramsay where kids may need another meal in addition to lunch. The meal would be similar to a summer program lunch – a unitized meal with a sandwich, fruit, milk, etc. We expect the program to begin in late May provided the grant is approved.
- City Council will hold Miracle Field Appreciation Night in Council Chambers on June 12 at 7:00 p.m. City Council will recognize donors who made it possible to match City funding to build the Miracle Field as well as Miracle League participants, coaches and volunteers.
- City Council will participate in the Ground Breaking Ceremony for the Miracle Field on June 16, 8:30 a.m., at the Lee Field.
- City Council will participate in the Mount Vernon Recreation Center Enhancement Unveiling (Washington Mystics) on June 16, 5:00 p.m., at Mount Vernon Recreation Center.

City of Alexandria, Virginia

MEMORANDUM

DATE: MAY 17, 2012

TO: PARK AND RECREATION COMMISSION MEMBERS

FROM: JACK BROWAND, ACTING DEPUTY DIRECTOR, PARK OPERATIONS
DEPARTMENT OF RECREATION, PARKS & CULTURAL ACTIVITIES

SUBJECT: PARK AND RECREATION COMMISSION - ITEM IV-B
PARK OPERATIONS UPDATE

2012 SPRING FOR ALEXANDRIA

On Friday May 4, more than 100 volunteers working at Four Mile Park, Beverley Park, Ft. Ward Park, George Washington Middle School, Ben Brenman Park, Founder's Park and Angel Park removed truckloads of weeds, tree branches, rocks and other debris from park flower beds, playground areas, and walking trails. See attached photos of work completed by these dedicated and appreciated volunteers.



Beverley Park Playground



Fort Ward Park Planting Beds

4TH ANNUAL STATEWIDE INVASIVE PLANT REMOVAL DAY

Natural Resources staff coordinated the 4th Annual Statewide Invasive Plant Removal Day on Saturday, May 5. A total of 44 volunteers in three teams removed 36 bags of Garlic Mustard from Chinquapin Park and adjoining Forest Park. Volunteers also removed a colony of Periwinkle and a colony of

English Ivy from the stream bank of Taylor Run along the main trail at Chinquapin Park. In addition, in late April, fourteen T.C. Williams High School students removed 25 bags of Garlic Mustard from Chinquapin Park.

CITY ARBORIST OFFICE SPONSORS URBAN FORESTRY WALKS

Throughout the year, staff from the City's Arborist Office sponsors educational and tree identification walks to City tree stewards and school-aged children. On April 18, 21 Tree Stewards of Arlington and Alexandria participated in a Tree Walk at Fort Ward Park; on May 12, 7 Tree Stewards of Arlington and Alexandria participated in a tree walk on the National Capital grounds; and on May 11, 14 first through fourth grade students at Maury Elementary School participated in a tree walk of school grounds. Fourteen Tree Stewards have registered for a send walk of the National Capital grounds scheduled for May 19.

FOREST PARK DEADFALL CLEANUP WORK COMPLETED

Work has been completed in providing cleanup of deadfall and other trail improvements along the trail in Forest Park between Chinquapin Park and Francis Hammond Parkway, and along the trail behind Maple Hill Place. The work is completed in response to concerns from residents and the Alexandria Fire Marshall to reduce available fuel for potential fires to be set along the path.

City of Alexandria, Virginia

MEMORANDUM

DATE: MAY 17, 2012

TO: PARK AND RECREATION COMMISSION MEMBERS

FROM: CHERYL ANNE COLTON, CPRP, REGIONAL PROGRAM DIRECTOR
OFFICE OF THE ARTS
DEPARTMENT OF RECREATION, PARKS AND CULTURAL ACTIVITIES

SUBJECT: **MAY 2012 COMMISSION MEETING, ITEM IV-C
UPDATE ON THE OFFICE OF THE ARTS AND ARTS COMMISSION
ACTIVITIES**

Please see Attachment:
OFFICE OF THE ARTS MONTHLY STAFF REPORT – MAY 2012.

**OFFICE OF THE ARTS MONTHLY STAFF REPORT
MAY 2012**

BUDGET:

Team Lead: Alisa Carrel

Status: On May 7, City Council approved the FY13 Budget, as well as the FY12 Fund Balance allocation. The following arts-related funding was approved:

- Grants Funding through the Arts Commission = \$179,937 - same as previous few years
- Public Art Master Plan = \$60,000 – from the FY12 Fund Balance
- Public Art Acquisition – FY13 – FY22 CIP: \$50,000 beginning July 1, 2012 with a projected incremental increase of \$50,000 each year through FY22 for a total of \$2.75 million. The 10-year CIP must be approved each year so it is subject to change.
- Public Art Conservation = \$15,000/year – Capital Funds
- Public Art Maintenance = \$15,000/year – Operating Funds

GRANTS PROGRAM:

Alexandria Commission for the Arts Grants Program

Team Lead: Cheryl Anne Colton

Status: The Arts Commission determined the conditional grant awards for Fiscal Year 2013. The conditional awards represented 24 grants in the amount of \$184,937 (pending \$179,937 City and \$5,000 Virginia Commission for the Arts (VCA) Funds). This accounts for approximately 73% of the total eligible requests of \$254,936.

The Arts Commission will confirm the awards after City Council approves the budget on May 7. This confirmation will not include VCA funds because Virginia's budget is approved in mid-June.

Grantees will receive notification of the pending grant awards at the Grant Recipient Recognition and City Galleries Artists Reception

Important Date(s): Grant Recipient Recognition and City Galleries Reception, Monday, May 21, 5:30 pm, formal program 6 pm, Chet & Sabra Avery Room 2000, City Hall.

PUBLIC ART POLICY:

Team Lead: Alisa Carrel

Status: At the May 8 Council meeting, the draft Public Art Policy was presented by staff and received by City Council. The Policy will be sent to the June 5 Planning Commission meeting through the Director of Planning and Zoning's report. Over the summer, meetings will be held with developers and their representatives. The Policy will be docketed for a September City Council public hearing. Meetings with stakeholders are ongoing. The link to the docket memo is: <http://dockets.alexandriava.gov/fy11/050812rm/di15.pdf>

PUBLIC ART PROJECTS:

Outdoor Temporary Public Art Projects – Special Opportunity Grant

Team Lead: Alisa Carrel

Status: The Selection Panel which includes members of the ACA Interdisciplinary Panel and members of the Public Art Committee met on April 30 and reviewed the 17 applications voted to award the grants to Matthew Harwood, Linda Hesh and Jane Franklin. All three artists are from the area. Staff, the Public Art Committee and interns will assist with obtaining the proper approvals necessary for implementation.

The former Duron Paint Building, Mount Vernon Avenue, Arlandria

Team Lead: Alisa Carrel

Status: The stage has been installed. Staff will submit a final report to the Virginia Commission for the Arts before June 1, 2012. The Four Mile Run Farmer's & Artisans Market opened the season on Sunday, May 6, 2012.

Contrabands & Freedmen's Cemetery Memorial Sculpture

Team Lead: Alisa Carrel

Status: It is anticipated that the artist presentations will occur in early July, followed by a two to four week public comment period. Commissioners will be notified as soon as the date is confirmed with the artists and selection panel. The three finalists are: Erik Blome, Crystal Spring, Illinois; Mario Chiodo, Oakland, California and Edward Dwight, Denver, Colorado. A ceremony to commemorate the beginning of construction will be held on July 7, 9am on site.

Police Memorial

Team Lead: Alisa Carrel

Status: A bake sale was held on May 10 to help raise funds for the Alexandria Police Memorial. The event took place at the Community Room at the new Alexandria Police Department headquarters on Wheeler Avenue and was sponsored by the Alexandria Government Employees Association.

Charles Hamilton Houston Memorial

Team Lead: Alisa Carrel

Status: A fundraising meeting was held which included Pat Miller, Beth Temple, Mame Reilly, Jim Henson and Alisa Carrel. Plans for a fall gala were discussed.

King Street Gardens Park

Team Lead: Cheryl Anne Colton

Status: On April 2, staff met with Rodger Digilio, Chair, King Street Gardens Park Foundation. Mr. Digilio wishes to obtain additional information on the following: the irrigation completed work, the planting plan for 2012 and, the white lights.

A future meeting will be held with Rodger Digilio, Marlin Lord and Department staff to discuss the above mentioned issues.

Important Date(s): Quarterly King Street Gardens Park Foundation Meeting, Wednesday, May 23, 7 pm, Durant Arts Center.

Captain Rocky Versace Plaza and Vietnam Veterans Memorial

Team Lead: Cheryl Anne Colton

Status: The Guilders' Studio will complete pointing work for the Memorial prior to the May 28 Memorial Day Ceremony.

Planning efforts have begun for the May 28, Memorial Day Ceremony. The Friends of Rocky Versace are leading the planning efforts. Councilman Frank Fannon has agreed to be a speaker for the event.

Important Date(s): Memorial Day Ceremony, May 28, 11 am, Captain Rocky Versace and Vietnam Veterans Memorial, 3701 Commonwealth Ave.

PUBLIC ART IN URBAN PLANNING:

Waterfront Plan

Team Lead: Alisa Carrel

Status: Pat Miller will be the Arts Commission's representative to the newly reconfigured Waterfront Commission.

ALEXANDRIA POET LAUREATE:

Team Lead: Cheryl Anne Colton

Status: Amy Young continues to host the “Writers Group” on Monday nights through the end of April in the Durant Arts Center’s Community Arts Room.

Two hundred and sixty-two people participated in Alexandria’s National Poetry Month activities. (Apr. 13, Poetry Slam, 90; Apr. 21, Earth Day Booth, 80; Apr. 22, Tribute to Jean Elliot, 35; Apr. 26, Poem in Your Pocket Day, 37; Apr. 26, Celebration of Small Poems, 20).

Ms. Young has designed two initiatives to encourage people to write poetry:

- “MAPP (*Mapping Alexandria in Poems and Pictures*),” a citywide art and poetry project. Residents of Alexandria (adults and children) are invited to write poems, paint or draw pictures or take photos that capture the spirit of the street they live on. Artwork and poems will be collected from April-August. Exhibits of these items will be held in the fall.
- “*Dog Days of August*,” Poems and photos of dogs will also be collected for the “Dog Days of August,” exhibition that will be held August 16 through August 26 in local businesses throughout the City.
- *Deadline for to submit poetry for both initiatives is August 10.*

Important Date(s): Writers Group meetings, Mondays, 7-9 pm, Community Arts Room, Durant Arts Center; Deadline to submit poetry for MAPP and Dog Days of August initiatives is August 10.

COLLABORATION:

Anti-Stigma/Mental Health Awareness

Team Lead: Cheryl Anne Colton

Status: The “Art Uniting People” artist reception and event was held on May 10, 6:30 pm, Lee Center, 1108 Jefferson St. Dr. Margaret Dowell, Maryland based award winning artist and professor at the College of Southern Maryland was the keynote speaker. Dr. Dowell discussed the emerging role of art as a powerful force in fostering an environment and society more supportive of recovery.

Ann Lee, a native Alexandria, performed the Prelude in B-Flat, Op. 23, No. 2 by Sergei Rachmaninoff. This piece was composed following his breakthrough after an experience of severe depression. This movement, marked “maestoso,” or characterized by majesty or a lofty breadth, is an expression of Rachmaninoff’s own feeling of victory, renewed energy and ardor for life, and a creative expression that could only come from depth of experience.

The “Art Uniting People” exhibition will be at the Lee Center through the end of September. The exhibit will then move to the Beatley Library and be on exhibit until the first week in January.

The wrap-up and pot-luck meeting is scheduled for Thursday, May 24, 4:30 pm, Lee Center.

Important Date(s): Art Uniting People wrap-up and potluck meeting, Thursday, May 24, 4:30 pm, Lee Center.

ARTS MARKETING INITIATIVES/SPECIAL EVENTS:

Alex Arts Awards

Team Lead(s): Alisa Carrel and Cheryl Anne Colton

Status: On April 24, 7 pm, the Alexandria City Council and the Commission for the Arts presented the Alex Arts Awards to Ulysses S. James, Music Director, Washington Metropolitan Philharmonic, the Little Theatre of Alexandria and Leah Valtin-Erwin, senior, TC Williams High School. Accepting the awards were Abigail Spangler for UI James, and Rachel Alberts, Vice Chair, Public Relations for the Little Theatre of Alexandria, and Leah-Valtin-Erwin. Award recipients received a beautiful ceramic window bowl created by artist Karin Abromaitis, a

Torpedo Factory artist, and the beautifully redesigned brass star created and donated by David Martin of Gold Works. The awardees will also be recognized at an event of their choice. U James will be recognized at the May 19, 3 pm Washington Metropolitan Philharmonic concert. The Little Theatre of Alexandria will be recognized at their annual meeting on for June 11, 6 pm at the Little Theatre of Alexandria. Ms. Valtin-Erwin has not yet chosen a second recognition date.

Important Date(s): Alex Arts Award Recognition for U James, May 19, 3 pm, Bishop Ireton High School; Recognition for Little Theatre, June 11, 6 pm, Little Theatre of Alexandria.

Branding Project

Team Lead: Alisa Carrel

Status: No new information.

Film Festival

Team Lead: Alisa Carrel

Status: No new information.

Youth Arts Festival

Team Lead: Cheryl Anne Colton

Status: The City's Interagency Special Events Committee approved the 3rd annual Youth Arts Festival for Saturday, June 9, noon - 4 pm, Buchanan Field, behind Jefferson Houston School.

The Festival is spearheaded by the Alexandria Redevelopment and Housing Authority in partnership with the Alexandria Department of Recreation, Parks and Cultural Activities, the Alexandria City Public Schools, the Northern Virginia Urban League, the Alexandria Commission for the Arts and the Campagna Center.

Youth Arts Festival Auditions are scheduled for Thursday, May 24, 12 noon – 5 pm, TC Williams High School, 3330 King St. Interested students should contact Jason Ellis 703-535-3175 or Shawn Thorpe 703-824-6875 to secure an audition time.

Important Date(s): 2012 Youth Arts Festival Committee Meetings, Thursdays, May 17, 24, and May 31, 10 am, Durant Arts Center; Auditions, Thursday, May 24, 12 noon – 5 pm, TC Williams High School, 3330 King St.; Youth Arts Festival, Saturday, June 9, noon – 4 pm, Buchanan Field, behind Jefferson Houston School.

CITY GALLERIES PROGRAM:

Call for Artists/Placements

Team Lead: Cheryl Anne Colton

Status: Ali Ringenburg, Director, Principle Gallery juried in 43 artists for the current Art in City Hall exhibition. The Art in City Hall exhibit is located on the 2nd floor of City Hall. The awards will be presented at Grant Recipient Recognition and City Galleries Reception, Monday, May 21. The exhibit runs until September 14, 2012

Northern Virginia High School Clay Connection Competition and Exhibit will be at the Durant Center through May 16. An awards ceremony is scheduled for May 16.

Important Date(s): Northern Virginia High School Clay Connection Competition and Exhibit through May 16, Awards Ceremony, 7 pm, Durant Arts Center; Grant Recipient Recognition and City Galleries Reception, Monday, May 21, 5:30 pm, formal program 6 pm, Chet & Sabra Avery Room 2000, City Hall, 301 King St.; Art in City Hall Exhibition through September 14, 2nd Floor, City Hall, 301 King St. Hours are 8 am – 5 pm, Mon. – Fri.

PROFESSIONAL DEVELOPMENT

Internship Program

Team Lead: Cheryl Anne Colton

Status: Lian-Yao Wang's last day was May 4. Four summer interns are secured: Washington Center for Internships and Seminars candidate: Philippe Ostigay, Senior, Concordia University, Montreal; Irene Dellest, Junior, James Madison University, Harrisonburg, VA; Sarah Strobel, Brigham Young University Washington Experience; and Mackenzie Tucker, Junior, College of William and Mary, Williamsburg, VA. The intern team will be in place by the end of May.

Staff is working to establish a department-wide internship program. Several internship opportunities were posted for the Department of Recreation Parks and Cultural Activities.

The Alexandria Collaborators will meet on May 14 to plan their June 13 workshop. The workshop will focus on fund-raising. It was suggested that members from United Way and corporations could provide insights on the best way to approach them for funding.

Important Date(s): Alexandria Collaborators Fundraising Workshop, Wednesday, June 13, 8:30 am-10:30 am, Durant Arts Center.

RESEARCH:

Local Arts Index & the Arts and Economic Prosperity IV Study

Team Leads: Alisa Carrel and Cheryl Anne Colton

Status: No new information for the Arts and Economic Prosperity IV Study.

Alexandria Quality of Life Indicators

Team Leads: Alisa Carrel and Cheryl Anne Colton

Status: No new information.

Submitted by Alisa Carrel and Cheryl Anne Colton

###

CALENDAR [May/June 2012]

Collection of poems from April through August:

MAPP (Mapping Alexandria in Poems and Pictures) – a citywide art and poetry project and Dog Days of August.” Send poems, art pieces and photos to: poet@alexandriava.gov

Youth Arts Festival Planning Meeting (s)

Thursdays, May 17, 24 and May 31, 10 am, Durant Arts Center

Alexandria Commission for the Arts Meeting and Public Hearing City's Public Art Policy

Tuesday, May 15, 7 pm, regular monthly meeting immediately following, Durant Arts Center

Northern Virginia High School Clay Connection Competition and Exhibition

Wednesday, May 16, 5:30 pm, Awards ceremony and closing for exhibition, Durant Arts Center

Fiscal Year 2013 Grant Recipient Recognition and City Galleries Artists reception

Monday, May 21, 5:30 pm, formal program begins at 6 pm, Room 2000, 2nd floor, Chet & Sabra Avery, Room 2000, City Hall, 301 King St.

King Street Gardens Park Foundation Meeting

Wednesday, May 23, 7 pm, Durant Arts Center

Art Uniting People/Anti-Stigma Exhibit and Program

Thursday, May 24, 4:30 pm, Lee Center, Wrap-up meeting.

Alexandria Arts Forum

Thursday, May 24, 12 noon, Durant Arts Center

Youth Arts Festival Auditions

May 24, 12 noon – 5 pm, TC Williams High School, 3330 King St., Interested students should contact Jason Ellis 703-535-3175 or Shawn Thorpe 703-824-6875 to secure an audition time.

Memorial Day Ceremony

Monday, May 28, 11 am, sponsored by the Friends of Rocky Versace, Captain Rocky Versace and Vietnam Veterans Memorial, 2701 Commonwealth Ave.

Executive Committee Meeting/Alexandria Commission for the Arts

Friday, June 8, 3 pm, Durant Arts Center

ACA Public Art Committee Meeting

Wednesday, June 13, 7 pm, Durant Arts Center

City Galleries:

- **City Council's Office**, Rm 2204, City Hall, Cianne Fragione, paintings, through July 2012.
- **Mayor's Office**, Rm 2331, City Hall, Inmates Art Exhibit through December, 2012.
- **Department of Planning and Zoning**, 2nd Floor, Rm 2100, City Hall, Charles Whestone, paintings through July 2012.
- **City Manager's Office**, Patsie Uchello, paintings, through July, 2012.
- **Second Floor, City Hall**, Art in City Hall Exhibit, various media, through September 14, 2012
- **Third Floor, City Hall**, "Growing Pains," mixed mediums, through July, 2012.
- **Market Square Lobby**, City Hall, Living Legends of Alexandria, photographed by Nina Tisara, through March 2013.
- **Department of Transportation and Environmental Services**, 4th Fl, City Hall, Gary Meus, photography, through July, 2012.
- **Main Gallery, Beatley Library**, Carol Dupre, paintings, through July, 2012.
- **Lee Center**, 1108 Jefferson Street. Upstairs Gallery, David Camero, paintings/collages, through July 2012; Director's Gallery, Matthew D. Kiehl, pen and ink, mixed media, through December 2012.
- **Durant Arts Center**, Matthew D. Kiehl, pen and ink, mixed media, through December 2012, community arts room; Living Legends of Alexandria, main gallery, through September 2012; Northern Virginia High School Clay Competition and Exhibit through May 16.

City of Alexandria, Virginia

MEMORANDUM

DATE: MAY 17, 2012

TO: PARK & RECREATION COMMISSION MEMBERS

FROM: PARK PLANNING, DESIGN & CAPITAL DEVELOPMENT TEAM
BETHANY A. CARTON, ASLA PARK PLANNER
LAURA D. DURHAM, CITY OPEN SPACE COORDINATOR
DAVID H. GHEZZI, AIA LEED AP ARCHITECT
JUDY LO, ASLA LANDSCAPE ARCHITECT
DANA W. WEDELES, PARK PLANNER
RON M. KAGAWA, ASLA LEED AP DIVISION CHIEF

SUBJECT: **ACTIVITIES UPDATE, APRIL-MAY, 2012**
OVERVIEW – SELECTED PROJECTS AT A GLANCE, ITEM V-D-i

Please see that attached items:

1. Active Park Projects including Capital Improvement Projects – Update
2. Active CFMP Projects Report – Update
3. External Request Projects – Update
4. Division Update Item V.ii

###

Active Park Planning Projects

Friday, May 11, 2012

8:57:48 AM

Lead	Project Name	Team	%Complete	Est. Completion
VDOT/NPS/PCC				
	Jones Point Improvement/Renovation	RMK JB		12-Jun-12
	Notes: RPCA Staff as City lead. Completion date remains June 25, 2012.			
VDOT				
	Four Mile Pedestrian Bridge	DW RK		01-Mar-12
	Notes: Contract drafting between NVRC and design consultant(s). Scope is being refined based on cost constraints.			
	Freedman's Cemetery	LD RMK DG		01-Nov-12
	Notes: Preconstruction meeting 10 April. Construction mobilization start on 01 May. 365 days of construction. Anticipated completion May, 2013.			
	Freedman's Cemetery Sculpture	AC RK	Preliminary Plan	
	Notes: Alisa Carrel coordinating RFP for artists. Timing based on anticipated construction schedule. 3 artists shortlisted.			
	Witter	BC RK	40% CA	01-Nov-12
	Notes: Final earthwork elements are concluding and field construction is underway. The project is 75% complete. Anticipated rectangular field delivery Summer 2012 and softball field/plantings Fall 2012.			
TE&S				
	Holmes Run trail Feasibility Study	DW		15-Feb-12
	Notes: TE&S is working with consultant team to improve trail between Brookvalley Park and 395. Three concepts have been proposed.			
	S. Washington St. Improvements	RPCA: DG, RK, J		
	Notes: 100% documents received 16 April. Construction start anticipated June 2012 with completion December, 2012			
	Trail Improvements			
	Notes: Demonstration using pourous paving, in collaboration with TES. Project in procurement. Expected to construct in spring.			
RPCA				
	1 & 7 East Del Ray	LD JL	99%	18-Aug-11
	Notes: Gameboards to be installed weather permitting. Plantings installed late September. Park dedication with DRCA to occur next Spring. Playground open to the public in mid-August.			
	ADA Study	LD, DG		
	Notes: Study in final draft. Anticipated delivery at end of April, 2012			

Lead	Project Name	Team	%Complete	Est. Completion
	Ben Brenman Dugouts and Press Box	DG BC		21-May-12
	Notes: To be replaced as part of the FY12 CIP. Investigation for structures/site requirements underway.			
	Ben Brenman Supervisor Room	DHG		10-May-12
	Notes: Scope is revised: BB office to be covered to new muster room so that existing muster room shall be returned to original use, field maintenance equipment storage. Drawings sent to GS for pricing.			
	Boothe Park Playground Renovations	JL, BC	10%	14-Dec-12
	Notes: Engineer Services Task Order(MASC Engineer of Record) to be submitted to Purchasing Department. Memo regarding scope sent to ACPS.			
	Brookvalley Playground repairs	JL, WP		01-Jun-12
	Notes: Replace swing set because of structural failure.			
	CAPRA Policies	JB RMK		
	Notes: Ongoing to sustain accreditation requirements.			
	Chinquapin Horticulture Improvements			
	Notes: Several landscape projects and site improvements in the areas surrounding the building to support horticultural sites			
	Chinquapin Light Pole improvements			
	Notes: Replacement as identified in the 2011 Engineering Analysis for Ball Field, Tennis and Sport Field Light Poles.			
	Dora Kelley Trail Improvements			01-Aug-12
	Notes: Sole Source Justification complete. Waiting for funding on July 1 to schedule project.			
	Drainage Issues into Colasanto Center	AC RK		26-May-12
	Notes: TES to proceed with regrading to divert field runoff, add 2 curb inlets to handle additional runoff, and tie in of RWL to Stormwater. Project underway.			
	Ewald Playground Repairs	JL, DC, TT		25-May-12
	Notes: Replace parts on order. Estimated delivery mid-April.			
	Fort Ward Ball Court Renovations	TT, BC		01-Aug-12
	Notes: Complete renovation scheduled for the last week in June 2012. Anticipated to be complete in August.			
	Fort Ward Furniture Replacement	DW TT	90%	
	Notes: All Picnic benches in Picnic Area 2 order. To be received in May. Two benches ordered. Two Grills remain to be ordered.			

Lead	Project Name	Team	%Complete	Est. Completion
	Founders park irrigation replacement	RK		01-Sep-12
	Notes: RFP for project in initial stages.			
	Four Mile Run Restoration	DW, RMK	90% design	
	Notes: Congressional reauthorization required to qualify for Army Corp permitting. Waiting on passage of Senate bill.			
	Ft Ward Park	LD		
	Notes: Interdept. MOU signed by all depts. Sept. 2011. Draft Management Plan RFP provided to Advisory Group for comment April 11, 2012.			
	Furniture Replacement	DW BC & Ops		01-Jul-12
	Notes: All furniture except Washington Way benches and grills ordered. Furniture to arrive in June.			
	Hensley Park Event Shelter	DG RK		
	Notes: Large open air shelter coordinated with Festival Event Area project. Allocation request submitted in April.			
	Hensley Park Festival Area			
	Notes: Site renovations to provide additional infrastructure capable of supporting large private/public events. Allocation request submitted in April.			
	Holmes Run Play area ADA connectors			01-Jul-12
	Notes: Estimate to be obtained.			
	Hooffs Run Playground Repairs	JL, DC		01-Mar-12
	Notes: Replace exit sections on tube slides. Parts on order. Estimated delivery mid-April			
	Hunter Miller Basketball Court Light timer	BC		15-Jul-12
	Notes: as identified in the 2011 Engineering Analysis for Ball Field, Tennis and Sport Field Light Poles.			
	Installation of bio-retention swale and pl			
	Notes: will serve to capture and treat nutrient-laden stormwater runoff generated at the dog park			
	James Bland Redevelopment	Laura		
	Notes: Land Acquisition tied to final site plan for development approved 9.06 action in March, 2012			
	King Street Gardens Improvements	AC		
	Notes: To be scheduled around farmers market (ends Oct., begins May)			

Lead	Project Name	Team	%Complete	Est. Completion
	Landover Park Irrigation	RT DC	90%	
	Notes: Working with electrical contractors to determine source of power for the system but the irrigation has been installed. Project is delaying planting.			
	Luckett Field Improvements	TT BC		15-Aug-12
	Notes: Raise Net funding allocated.			
	Marina Electrical Upgrades	JH DW		
	Notes: new Electrical wiring for cameras; Divide 30 Amp receptacles for transient boaters G/H pier; reduce amp at E/F and 2 amps at E/F			
	Maxicom Audit	KW BC		
	Notes: Data changed in database for Charles Houston Rec Ctr. Formulating RFP's for physical inventory and data collection for irrigation city-wide. Pilot audit project planned for Summer 2012.			
	Montgomery Court Lights Replacement	BC RJ CL		16-May-12
	Notes: Dominion Power payment request received February 23. Payment Voucher submitted to RPCA Finance April 5 for \$2,734.37.			
	Montgomery Park Tennis Court Repairs	BC RMK RT		14-May-12
	Notes: American Tennis completed phase 1 of the repairs April 4. The contractor will monitor the repairs for two weeks, and complete phase 2 of the court surfacing when ambient temperatures allow.			
	Mount Jefferson Playground Renovation	JL	90%DD	01-Aug-12
	Notes: Purchase Order approved. Finalizing 100% construction plans. Construction anticipated to start mid-late April.			
	Mount Jefferson/WOD soft trail connector	JL LD		01-May-12
	Notes: Citizen Request. Provide new safe entry point to greenway from Route 1.			
	Old Town Pool Filter replacement	RB DG		
	Notes: Replace failing Swimming Pool Filter System components and non-compliant drain covers at Old Town Pool.			
	Oronoco Bay Irrigation Replacement	RK		01-Sep-12
	Notes: RFP for project in initial stages.			
	Park Inventory	DW	90%	14-Sep-11
	Notes: All data collected. Minor edits in GIS remain. Organization of information to be completed in format to inform Park Framework plans.			
	Park Standards	BC JL		01-Jun-12
	Notes: Next draft anticipated for review May 25			

Lead	Project Name	Team	%Complete	Est. Completion
	Parking Improvements	BC TT		01-Jul-12
	Notes: Minor Amendment to Ben Brenman SUP required. Staff is completing necessary plan revisions.			
	Pavement Improvement	DG		
	Notes:			
	Rehabilitation of new Parcels	LD	60%	01-Jul-11
	Notes: Park Plan approved by PRC in March 2011. Implementation of Phase I expected completion May, 2012.			
	Replacement of light and power pedest			
	Notes: Allocation of \$49,000 in Jan 2012			
	Simpson Playground Repairs			08-Jun-12
	Notes: Replace slide and other parts on play structure. Parts on order.			
	Simpson Tennis Court Improvements	BC	0%	15-Jun-12
	Notes: Project anticipated to be complete Summer 2012. Purchase order completed.			
	Sunset ADA path	JL DC		01-Jun-12
	Notes: Provide required ADA park entrance to play areas.			
	Sunset Playground Repairs	JL DC		01-Jul-12
	Notes:			
	Timberbranch Bridge Replacement	JL		01-Oct-12
	Notes: Requisition to be submitted to Purchasing using MASC Bridge repair contract. Anticipated completion Fall, 2012			
	Waterfront trail improvements	JL RJ		
	Notes: Project in progress - Roberdeau and Windmill Hill			
	Waterfront Trail Upgrades	Randy/Judy		15-Jun-12
	Notes: Scope refinements and cost estimates to be obtained Spring 2012 (in coordination w/ TES as applicable).			
	Windmill Hill Basketball Court Renovation	RJ CL BC		15-Jun-12
	Notes: Project is approved by Purchasing. Anticipate renovation in Summer 2012.			

Lead	Project Name	Team	%Complete	Est. Completion
	Windmill Hill Dog Area Improvements Notes: Install Landscape Barrier	DW JL RJ		
	Windmill Hill Fence Repair Notes: Part of Bball renovation	BC		
	Windmill Hill Irrigation Replacement Notes: RFP for project in initial stages.	RK		
	Windmill Hill Playground Renovation Notes: Part of Master Plan	JL		
	Windmill Hill Wayfinding Sign Replaceme Notes: Part of Master Plan Project	DW		01-Aug-12

P&Z

	Arlandria Implementation Notes: Ongoing planning and implementation of Phase I of Four Mile Run Park Expansion and Community Building.	LD DW	80% Planning	
	Beauregard Corridor Small Area Plan Notes: Ongoing open space and park small area plan issues are being discussed with stakeholder group, staff and ACPS. Plan scheduled for May Planning Commission and City Council public hearings.	LD RMK	90% Planning	
	Braddock Small Area Plan Notes: G. Services providing property mgmt for open space property on N. Henry with 18 mo. Tenant lease signed in 2/2011. Ongoing discussions with P&Z on remaining open space.	LD	90% Planning	
	Carlyle Plaza II Notes: South half of the Eisenhower East Circle Park and publicly accessible open space deck. Anticipated to be docketed for Planning Commission June, 2012.	BC	30% Planning	
	Eisenhower ASA Notes: DSUP for ASA tanks and above structure field was approved by Planning Commission and City Council in October, 2011. Anticipate field use in 2015/2016. Final Plan #1 comments returned to applicant.	BC, RMK		
	Eisenhower Avenue Widening Notes: 30% Submission Drawings reviewed and comments submitted to T&ES. Anticipate 60% Drawings in April/May.	BC RMK	30% Design	
	Eisenhower East Block 2 and 3 Notes: Concept Discussions underway for development on Blocks 2 and 3 in Eisenhower East including an urban square park.	BC		

Lead	Project Name	Team	%Complete	Est. Completion
	Eisenhower Station	BC, RMK	40% Design	
	Notes: Eisenhower Metro Station Square final design in progress.			
	Four Mile Run ASA	RMK BC DW	10% Design	
	Notes: Approved by Planning Commission and City Council in March, 2012. Final Site Plan being developed.			
	Landbay K	BC RMK		01-Oct-12
	Notes: Construction underway. Piling work completed and wall construction is underway. Park construction completion expected Spring 2013.			
	Potomac Avenue	BC RMK	80% Construction	30-Sep-11
	Notes: Minor modifications anticipated with next as-built submission. Replanting anticipated to be complete in April.			
	Potomac Greens Park	BC	85% Construction	
	Notes: Construction complete. As-Builts expected Summer, 2012.			
	Potomac Yard/Landbay D	BC	0	30-Mar-12
	Notes: Environmental remediation on-going.			
	Potomac Yard/Landbay I/J Parks	BC		01-Jan-13
	Notes: Anticipate construction early 2012 and acceptance by the City for phase one (Custis) late 2012 and phase two (Howell) late 2013.			
	Public Safety Center	RK	70% Construction	01-Sep-12
	Notes: Project Complete. Ribbon cutting, November, 2011.			
	Ramsey House Visitor's Garden	JL RK		
	Notes: Garden Club of Alexandria and PZ BAR Staff project. Project scoped only. MOA to be developed upon receipt of additional materials. No activity since 2011. Project likely terminated by GCA.			
	Route 1 Improvements	BC	60% Design	
	Notes: Design coordination ongoing with T&ES for Phase II Mass Transit project.			
	Waterfront Plan	LD RK		01-Sep-11
	Notes: The City Council approved the Waterfront Plan in January, 2012. Waterfront Commission to serve as advisory group for implementation starting Spring, 2012.			
ACPS				
	Hammond Upper Field	DW RMK		
	Notes: Field construction to begin in May 2012. Anticipated completion Summer, 2012. ACPS led project. Lights are not included.			

Lead	Project Name	Team	%Complete	Est. Completion
	Jefferson-Houston	DW RMK		01-Sep-14
	Notes: Concept Plan #1 submitted to the City on 06 April. BAR in June. Next Community mtg, June 4.			

City of Alexandria, Virginia

MEMORANDUM

DATE: MAY 17, 2012

TO: PARK & RECREATION COMMISSION MEMBERS

FROM: PARK PLANNING, DESIGN & CAPITAL DEVELOPMENT TEAM
BETHANY A. CARTON, ASLA PARK PLANNER
LAURA D. DURHAM, CITY OPEN SPACE COORDINATOR
DAVID H. GHEZZI, AIA RPCA ARCHITECT
JUDY LO, ASLA LANDSCAPE ARCHITECT
DANA W. WEDELES, PARK PLANNER
RON M. KAGAWA, ASLA LEED AP DIVISION CHIEF

**SUBJECT: CAPITAL IMPROVEMENT PROGRAM
EXTERNAL PROJECT REQUESTS – SPRING 2012**

ITEM:

The Park Planning, Design + Capital Development Division of RPCA has received one external project request that would require City funds for the 2012 spring Park and Recreation Commission review cycle (for FY14 funding), consistent with the established process for such projects (see attached memo dated March 2011). The following item is submitted for review by the Park Planning District Commissioners (application is attached for reference):

III. Park Planning District III.

1. Holmes Run Trail Fitness Equipment

The proposed project requests an expansion of the existing fitness equipment to provide three new pieces of equipment. The existing exercise area on the Holmes Run Trail currently has a set of parallel bars and a balance beam located near the Beatley Bridge. Over the years, approximately three pieces of fitness equipment along the trail have been removed due to damage, age, or safety and have not been replaced. The 2011 Needs Assessment identified a reported need for fitness stations in the vicinity of Holmes Run Trail ranging from 20% to 60% with approximately 50% of the need being met. The applicant is currently conducting a petition of trail users.

Due to the proximity to the Holmes Run Stream, internal inter-departmental review will be required and should land disturbance for this project exceed over 2,500 square feet, approved plans and permits will also be required. The initial capital expenditures for the proposed project, dependent upon design, subsurface treatment, materials, and installation, are anticipated to range from \$5,000 to \$10,000.

Minimal additional operating costs, including administrative processing and annual maintenance are also anticipated. No private matching funds are currently proposed with the project, however, volunteer efforts are anticipated to support scheduled facility maintenance. (Project contacts: Laura Durham and Judy Lo)

Per the External Project Request Process, please review the above material and attached project requests and provide recommendations to the full Commission for consideration at the June 2012 Park and Recreation Commission meeting.

###

City of Alexandria, Virginia

MEMORANDUM

DATE: MARCH 17, 2011

TO: PARK & RECREATION COMMISSION MEMBERS

THRU: JAMES B. SPENGLER, DIRECTOR
RECREATION, PARKS & CULTURAL ACTIVITIES

FROM: PARK PLANNING, DESIGN & CAPITAL DEVELOPMENT TEAM

SUBJECT: CAPITAL IMPROVEMENT PLAN (CIP) - PROCESS IMPROVEMENTS
• **EXTERNAL PROJECT REQUESTS - FOR USE OF CITY FUNDS**

ITEM:

The Park Planning, Design + Capital Development Division of RPCA is recommending establishment of a series of processes related to proposed project development in the Department of Recreation, Parks & Cultural Activities and City Capital Improvements Project process.

The purpose of this memorandum is to provide an overview of the process as related to **External (Citizen) Project Requests-For Use of City Funds** that are proposed for expenditure on projects not included in the City Capital Improvements Project budget.

A. DISCUSSION OVERVIEW:

Periodically, new projects are suggested by citizens, independent organizations or other interest groups. To date, a standardized means of prioritizing requests in context with ongoing initiatives or availability of resources has not been utilized.

Staff is proposing a process for review that will provide a predictable and standardized framework for fair comparative evaluation, decision making and guidance. The process evaluates proposed project work for consideration in context with other/ongoing City interests, available resources and staff capacity. The process is based on twice yearly review of citizen project proposals, review and prioritization of recommended projects by each of the three Districts of the Park & Recreation Commission. This method, described below, will provide staff with guidance related to new project requests as capital improvement projects are requested and considered City-wide.

B. PROJECT PROPOSAL, REVIEW AND IMPLEMENTATION PROCESS

Project Proposals

Project proposals will be accepted from citizens throughout the year by RPCA staff.

1. Proposals may be submitted by interested parties to RPCA staff using standardized project forms (as attached).
2. Proposals will be qualified and reviewed during the subsequent evaluation process date.
3. Project proposals will be considered in one of the three geographic Park Districts in which the project resides. Park Districts (I-III) are as defined by the Park & Recreation Commission.

Qualification Conditions

Qualification conditions/criteria include the following:

1. Provision of completed project request form and information.
2. Civic Association or other interest group recommendation for approval in writing.
3. Review for any potential conflict(s) with City initiatives.

Submission Deadlines

Deadlines for submission will be November 01 and May 01 for qualification by staff.

1. Staff will distribute qualified requests to Commissioners at the November and May (typically scheduled during third week of the month) Park & Recreation Commission meeting(s).

Review Cadence/Dates

A twice-yearly review/recommendation and follow-up/review process will be implemented by Park & Recreation Commission members in coordination with staff.

1. Review and recommendations related to project proposal information will be performed at the December and June Park & Recreation Commission meetings.

Evaluation Criteria

Typical Evaluation Criteria will be based on qualification conditions and the following:

1. Does the requested project contribute to the achievement of The City Council Strategic Plan and existing City-wide goals, policies, plans or Department work programs?
2. What are the general public benefits/public good of the project as related to anticipated costs?
3. What is the total cost (capital implementation and impact of projected annual operating expenses)?
4. Does the requested project propose use of private funds to match public investment? If so, are the funds in-hand?

Evaluation Process

Proposals will be evaluated by Park & Recreation Commissioners who represent the District in which the project is proposed.

1. District Commissioners will recommend project priorities and funding for their District to the full Commission for consideration.
2. Staff will provide technical guidance and assist the Commission in responding to requests for clarification/additional information.
3. Staff will provide guidance to the Commission that relates proposed projects relevance to existing and proposed Department work program(s).
4. The full Commission will evaluate proposals from each District and recommend a City-wide order of priority to staff as guidance in preparing the RPCA Capital Improvement Plan/Capital Funded Maintenance Program.

Implementation

Commission recommended proposed projects will advance in the following manner:

1. If funds for a Commission recommended project are available in the Department's current fiscal year budget, the project will be integrated into the Department's work plan.
2. If funds for a Commission recommended project are not available, the request will be included as a candidate in the City Capital Improvement budget during the next budget cycle for review at a City-wide level. Projects that are supported/funded in the City budget will be integrated with the Department's Capital Improvement Project work plan.
3. Projects not supported by existing funds or the City's Capital Improvement Project budget process may be resubmitted for (re)consideration in the next evaluation process.
4. Qualified Projects not supported as Commission recommendations, by existing funds or in the City Capital Improvement Project budget may be resubmitted for (re)consideration in the next evaluation cycle.

Follow-Up

Staff will provide a quarterly update to the Commission on progress of approved projects as related to schedule, timing and completion.

March 17, 2011

Page 4 of 4

C. SUSTAINING PROCESS & FUTURE MODIFICATIONS

It is recognized that the review/recommendation process may evolve and transforms as it anticipates and adapts to changes over time. Staff may periodically recommend to the Commission that the process be supplemented, amended or modified as the scope of work, complexity and/or quantity of project requests evolves.

ATTACHMENT

1. Project Request Form V2.0 01.25.2011

STAFF:

- Bethany A. Carton, ASLA; Park Planner, RPCA
- Laura D. Durham, City Open Space Coordinator, RPCA
- Judy Lo, ASLA; Landscape Architect, RPCA
- Dana W. Wedeles, AICP; Park Planner, RPCA
- Ron M. Kagawa, ASLA LEED AP; Division Chief, RPCA

###



**DEPARTMENT OF RECREATION, PARKS
AND CULTURAL ACTIVITIES**

1108 Jefferson Street

Alexandria, Virginia 22314

Phone (703)746-4343

Fax (703)838-6344

James B. Spengler
Director

Thank you for your interest in improving our parks!

Project requests can be made by submitting the Citizen Project Request form to the Park Planning, Design + Capital Projects staff.

Staff will accept requests throughout the year. Any requests received from April 2nd through October 1st will be distributed to the Park and Recreation Commissioners at the November Park and Recreation Commission meeting (typically held the third Thursday of the month). Requests received from October 2nd through April 1st will be distributed at the May Park and Recreation Commission meeting. Commissioners will make recommendations related to the project proposals at the January and June meetings.

Commissioners who represent the District in which the project is proposed and will base their evaluation on the following criteria:

1. Does the requested project contribute to the achievement of the City Council Strategic Plan and existing City-wide goals, policies, plans or Department work programs?
2. What are the general public benefits/public good of the project as related to the anticipated costs?
3. What is the total cost (capital implementation and impact of projected annual operating expenses)?
4. Does the requested project propose use of private funds to match public investment?

Staff will provide technical guidance and any additional information throughout the evaluation process.

If funds for a commission recommended project are available in the Department's current fiscal year budget, the project will be integrated into the Department work plan. If funds are not immediately available, the request will be included as a candidate in the City Capital Improvement budget during the next budget cycle (in the fall) for review at a City-wide level.

Projects that do not receive funding or are not supported by the Commission may be resubmitted for reconsideration in the next evaluation cycle.

Completed forms can be sent to Laura.Durham@alexandriava.gov or mailed to Park Planning, Design + Capital Development, 1108 Jefferson Street, Alexandria, VA 22301.

Alexandriava.gov



Submittal Date: March 30, 2012

PROPOSED PROJECT NAME - Holmes Run Park Trail Fitness Equipment

Name of Submitting Citizen or Representative

Elizabeth Wright, Connie West, and Brian Marquis

Group or Association (if applicable) The Holmes Run Park Committee

Phone, address, Email, c/o Elizabeth Wright, 113 S Ingram St. Alexandria VA 22304
H 703.370.9463, Cell 703.447.3325 eliz.wright@alumni.umw.edu

For questions about the proposed site layout contact Brian Marquis

P 703.519.7916 F 703.549.4216 E Brian@MarquisGraphicDesign.com

Park District No. District III Park & Recreation Commissioners - Richard A. Brune and John Sullivan

Does the proposed project address a safety concern? No Yes, explain

Currently, people who jog or run along the trail, frequently stop or pause for breaks, to stretch, or to exercise. Sometimes joggers/runners do not move off the trail to stretch or exercise. When they are not far enough from the trail, their stretching motions create a safety hazard or interference with other runners, bicyclists, baby strollers, and other walkers on the trail. We are proposing that the Parks Department enlarge the existing exercise area and add equipment. This project will allow runners and joggers to take breaks, exercise, and/or stretch in the designated area rather than staying on the trail surface.

Project Type (check one) **Capital Improvement project**

Description of the Project - Expand the existing Exercise/Fitness area along the side of the Holmes Run Park multi-use trail. Currently there are a set of Parallel Bars and a curved Balance Beam on the site.

As part of another planned Parks Dept. project, the existing Balance Beam will be moved a few feet from its current location to comply with new safety guidelines. The existing Parallel Bars will remain in place. The ground framing around this current exercise site should be enlarged to increase the "fall zone" around the equipment, to be in compliance with the current safety guidelines.

We propose this area to be further expanded to include three additional pieces of equipment: multi height Pull-Up bars, a Sit-Up bench, and Step-Up steps. Previously, each of these mentioned pieces of equipment were installed along the trail a few hundred yards from this site. A few years ago all three: the Pull-Up Bars, Sit-Up Bench and Step-Up steps were removed for maintenance, yet never replaced. This was done without community notification nor input.

Many people regularly use the remaining balance beam and parallel bars every day. The additional pieces of exercise equipment will complement the existing equipment, creating a well rounded exercise space.

The Holmes Run Park Committee requests modification of the current fitness area to consolidate the location of the existing equipment and, also, to replace the equipment which was removed as noted in the previous paragraph. By re-installing the previous equipment, this would re-establish this space as a fitness and exercise area.

Provide a project justification/rational - The requested equipment previously existed in the park and was well used; this is probably one of the reasons the equipment needed maintenance. The Holmes Run Park Committee is concerned that the equipment was removed rather than properly maintained. We are not requesting anything new; we are requesting restoration of previously installed equipment. This area of the park is heavily used through all seasons and is a favorite area for all types of outdoor fitness activities by all ages of people. Restoring those three pieces of equipment will provide a complete stretch and exercise area.

Please attach any additional information including site maps, if necessary

See materials supplied by Brian Marquis.

Are any of the following resources available? – Volunteers – any task that volunteers could assist on scheduled basis, such as spreading mulch in the exercise areas, painting.

In-kind donation - Site layouts and plans including vendors and equipment specifications provided by Brian Marquis.

Anticipated Project Cost -

- 3 pieces of new equipment, the Pull-Up Bars, Sit-Up Bench and Step-Up Stand - \$2,555
- Installation of the 3 pieces of equipment - \$1,000
- Additional site preparation, borders and added surface material - \$1,400
- Total materials and labor costs** **\$4,955**

For Park Planning, Design, and Capital Development Staff completion upon receipt

Anticipated involved staff: _____ Site Analysis _____ Construction Administration (Staff)
 _____ Design _____ Design and Construction
 _____ Property Acquisition/ Open Space _____ Specification
 _____ Development (Sup, DSP) _____ Arts
 _____ Feasibility Study _____ Coordination of Volunteer Project
 _____ Small Area Plan _____ Special Projects
 _____ Graphics for Special Events _____ GIS Information for Civic Group
 _____ Publication/Graphics/Maps _____
 _____ Other _____

Anticipated Public Meetings: _____ Park & Recreation Commission _____ Planning Commission
 _____ Board of Architectural Review _____ City Council
 _____ Neighborhood or Civic Association _____ Youth Sports
 _____ Waterfront _____ Arts Commission
 _____ Other _____

Anticipated Schedule: (Deadlines) Planning _____ Construction _____
 Design _____ Other _____

Resources **Index/OCA Code**

Funding: Design \$ _____

Funded: Construction \$ _____

Unfunded: Other _____

Matching Funds: _____

Anticipated Cost \$ _____

Park Planning Section _____ Date _____

Capital Projects Section _____ Date _____

RPCA Approval: _____
 Division Chief, Park Planning Design & Capital Development _____ Date _____

Project Team: _____

Project Number: _____

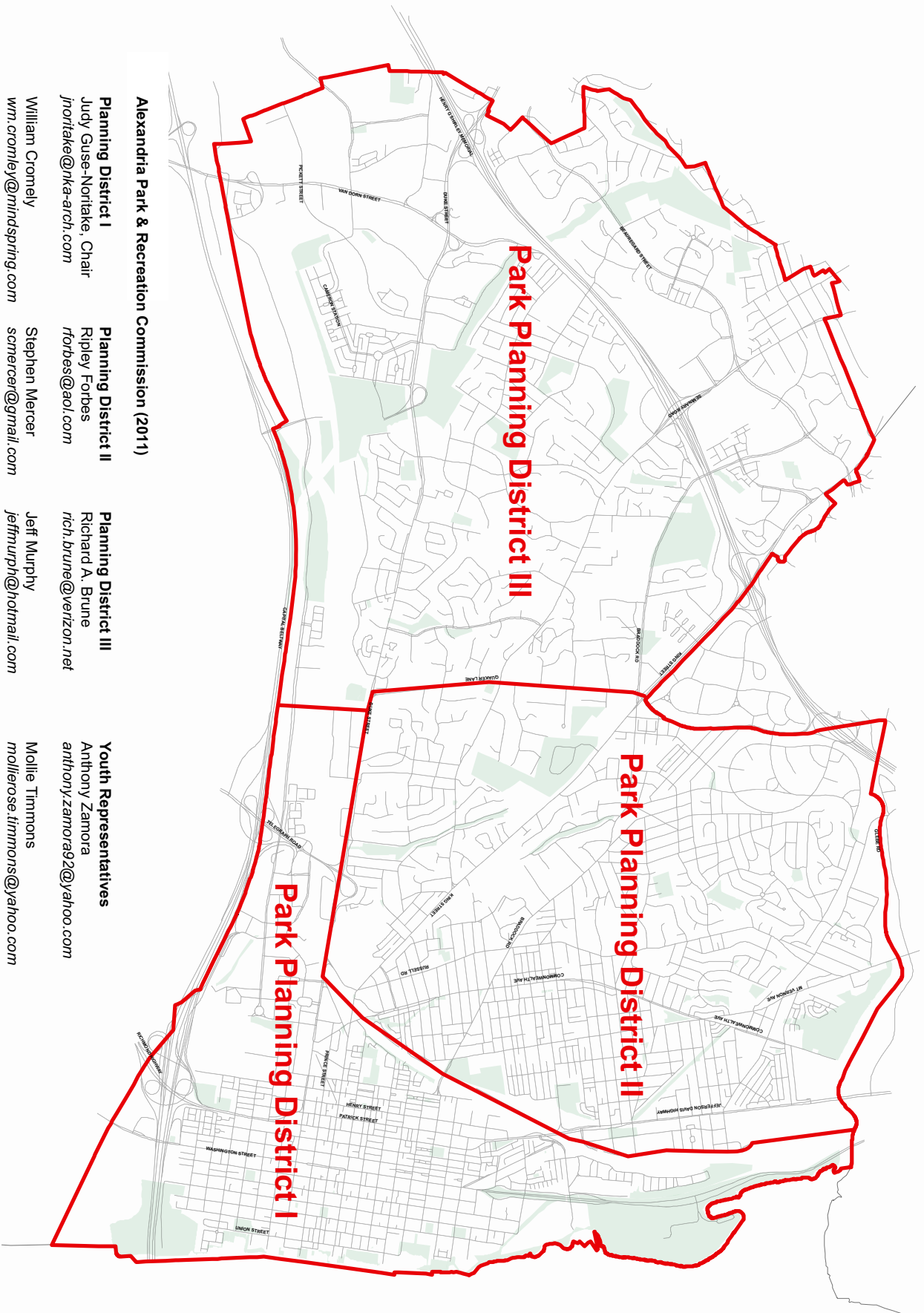

Alexandria Park & Recreation Commission (2011)

Planning District I
 Judy Guse-Nortlake, Chair
 jnortlake@nka-arch.com

Planning District II
 Ripley Forbes
 rforbes@aol.com

Planning District III
 Richard A. Brune
 rich.brune@verizon.net

Youth Representatives
 Anthony Zamora
 anthony.zamora92@yahoo.com

William Cromley
 wm.cromley@mindspring.com

Stephen Mercer
 scmrcer@gmail.com

Jeff Murphy
 jeffmurph@hotmail.com

Mollie Timmons
 mollierose.timmons@yahoo.com

Gina Baum
 ginabaum@aol.com

Robert Moir
 rkmoir@comcast.net

John Sullivan
 jsullivan@cement.org

PLAN VIEW/FOOTING LAYOUT

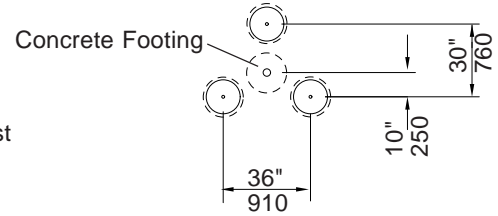

DETAIL DIRECT BURY

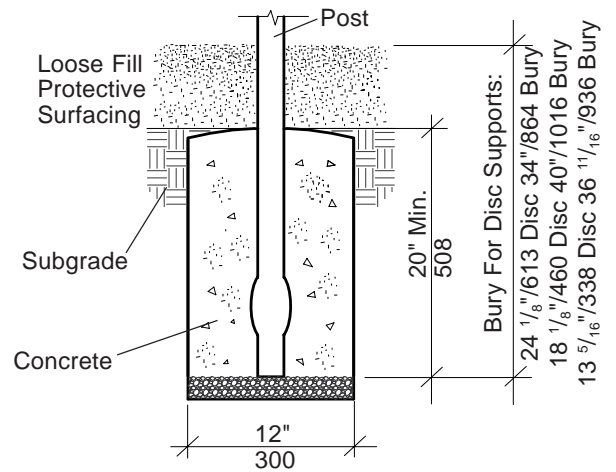

DETAIL DISC ATTACHMENT

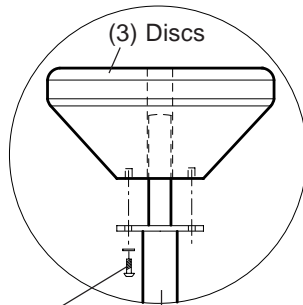

(9) 3/8" x 7/8" BHCS w/ Pin w/ 3/8" SAE Flat Washers

(3) Supports

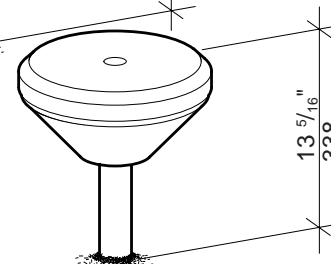
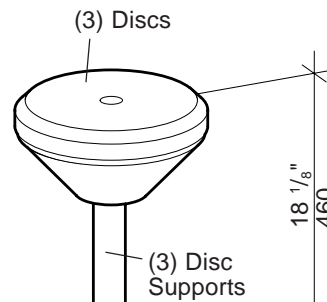
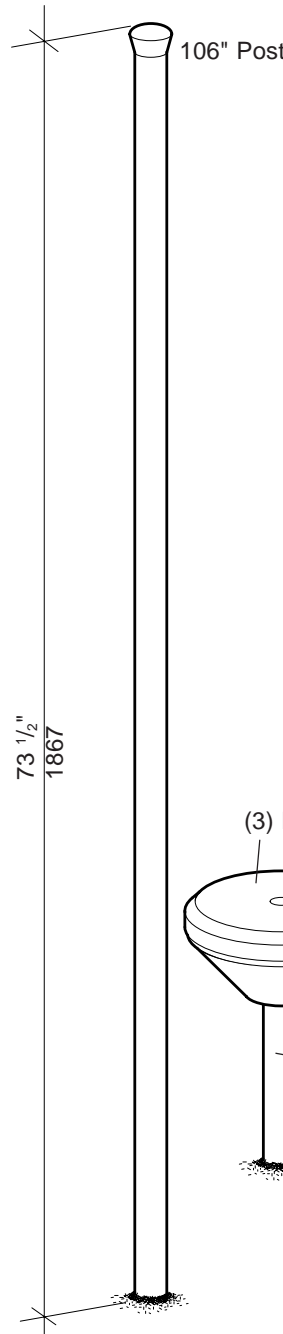
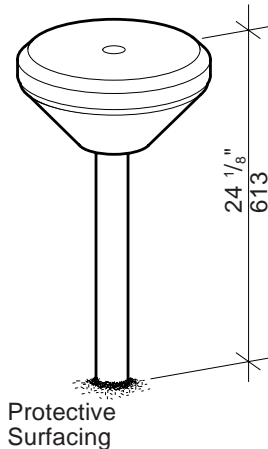



J:\SPECS\138\13801800.P65

Sports & Fitness 137965 Step Up

Parts List

Part#	Description	Qty.
126956-00	Disc, Specify Color	3
120600-00	Disc Support 16" (DB), Specify Color	2
120601-00	Disc Support 24" (DB), Specify Color	1
123322-00	Post 2 3/8", Specify Color	1
120918-00	Disc Climber Hardware Package	3
100196-00	3/8" x 7/8" BHCS w/Pin, SST	9
100365-00	3/8" SAE Flat Washer, SST	9
156847-00	Play Safe Label, 5-12 Yrs.	1

DB = Direct Bury

Specifications

Disc: Rotationally molded from U.V. stabilized linear low density polyethylene, disc measures 14" in diameter x 7" high, color specified.

Support: Weldment comprised of 1.900" O.D. RS-20 (.090" - .100"), 1.315" O.D. RS-20 (.080" - .090") and 3/16" x 5" diameter plate. Finish: ProShield®, color specified.

Post (2 3/8"): Fabricated from 2.375" O.D. RS-20 (.095"-.105") galvanized steel tubing. Finish: ProShield, color specified.

Fasteners: Primary fasteners shall be socketed and pinned tamperproof in design, stainless steel (SST) per ASTM F 879 unless otherwise indicated (see specific product installation/specifications).

Installation Time: DB - Approx. 3 man hours

Concrete Req.: Approx. 6 cu. ft.

Weight: 64 lbs.

Fall Height: 24 1/8" (0,61 m)

Installation Instructions

- 1) Dig footing holes spaced as shown.
- 2) Attach discs to supports using 3/8" x 7/8" BHCS w/Pin with 3/8" SAE flat washers.
- 3) Position post and disc supports in footing holes, plumb and level.
- 4) Pour concrete footings. Allow concrete footings to cure a minimum of 72 hours before users are allowed to play on the structure.
- 5) Install protective surfacing before users are allowed to play on the structure.

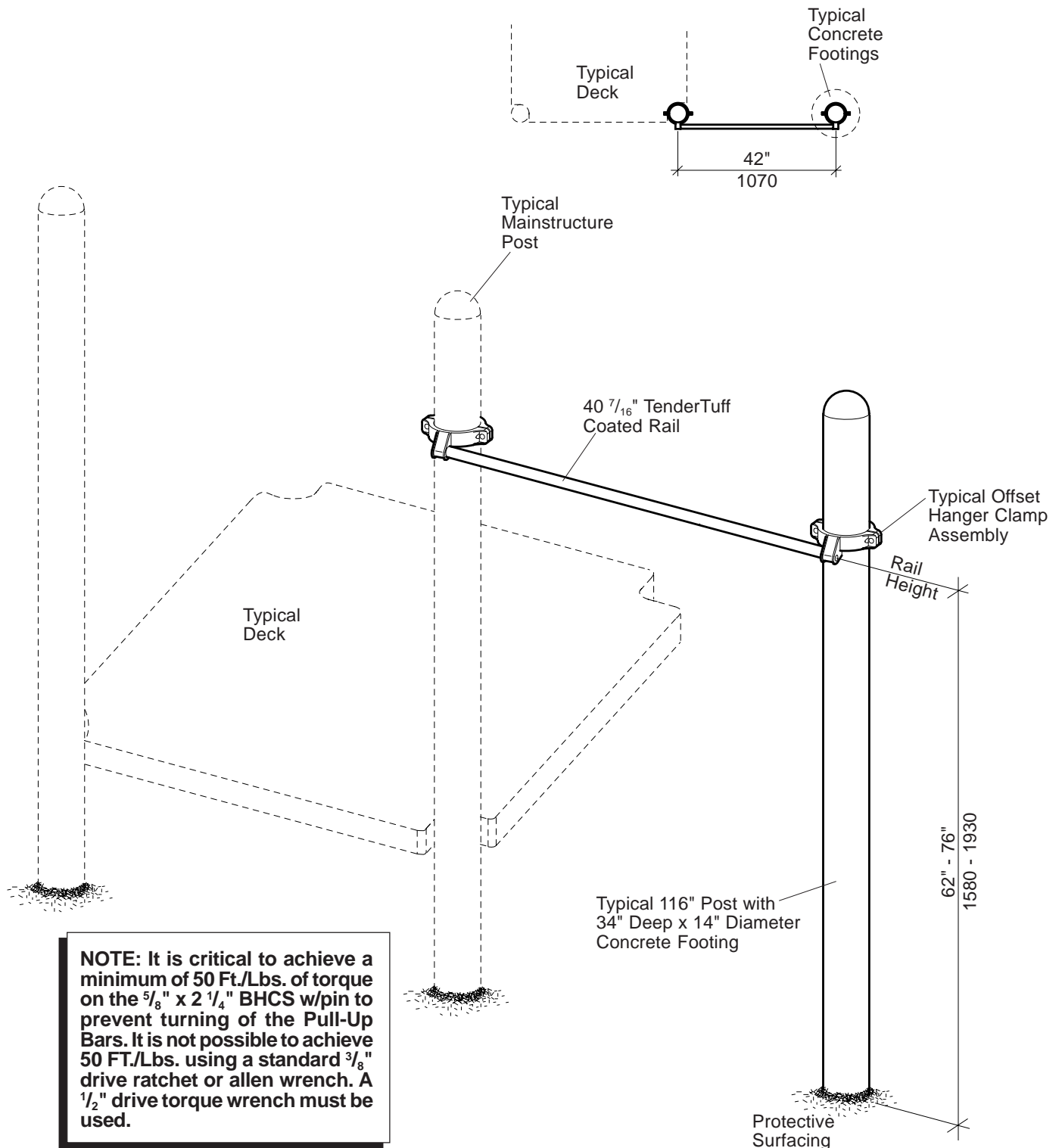



J:\SPECS\146\14657500.P65

PlayBooster®111357 Chinning Bar

Parts List

Part#	Description	Qty
107694-00	116" Aluminum Post, Specify Color	1
108569-00	40 7/16" TenderTuff Rail, Specify Color	1
105327-01	5" Half Clamp, Specify Color	2
113729-00	Offset Hanger Clamp, Specify Color	2
100610-00	1/4" x 5/8" Drive Rivet, SST	2
100351-00	3/8" Tee Nut, SST	4
100198-00	3/8" x 1 1/8" BHCS w/Pin, SST	4
100203-00	5/8" x 2 1/4" BHCS w/Pin, SST	2

Specifications

Rail: Weldment comprised of 1.125" O.D. x 11 GA (.120") steel tubing with 203 or 303 stainless steel 5/8" threaded inserts. Finish: TenderTuff, color specified.

Post: See PlayBooster (PB) General Specifications.

Offset Hanger

Clamp Assembly: Cast aluminum. Finish: ProShield, color specified.

Fasteners: Primary fasteners shall be socketed and pinned tamperproof in design, stainless steel (SST) per ASTM F 879 unless otherwise indicated (see specific product installation/specifications).

Installation Time: Approx. 1 1/2 man hours

Concrete Req.: Approx. 1.6 cu. ft.

Area Req.: 6' (1,83 m) minimum use zone

Weight: 41 lbs.

Installation Instructions

- 1) Dig footing hole spaced as shown. Refer to the Typical Concrete Footing Detail sheet.
- 2) Set post in footing hole and attach rail assembly to post at height shown using offset hanger clamp. Refer to the Typical Offset Hanger Clamp Assembly sheet. **NOTE: It is critical to achieve a minimum of 50 Ft./Lbs. of torque on the 5/8" x 2 1/4" BHCS w/pin to prevent turning of the Pull-Up Bars. It is not possible to achieve 50 FT./Lbs. using a standard 3/8" drive ratchet or allen wrench. A 1/2" drive torque wrench must be used.**
- 3) Temporarily brace post in plumb position and level rail. Pour concrete footing.
- 4) Install drive rivets in clamps. Refer to the Typical Offset Hanger Clamp Assembly sheet.
- 5) Install protective surfacing before users are allowed to play on the structure.

DETAIL

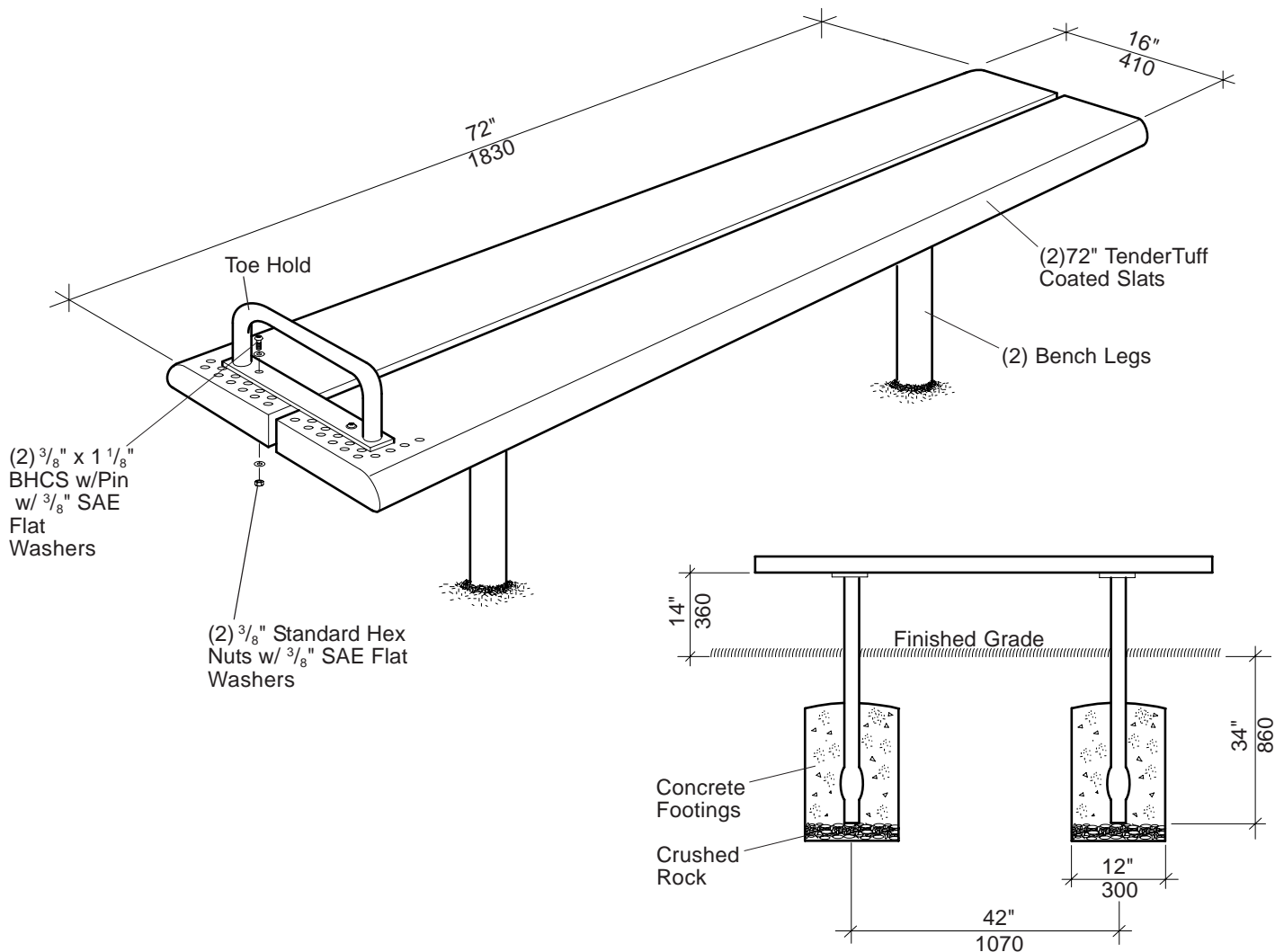
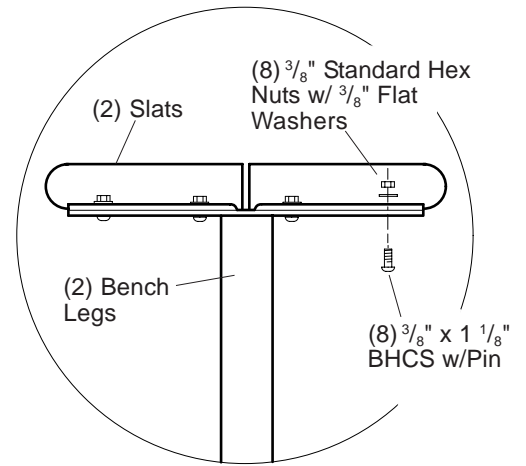

Sports & Fitness

100058 Sit-Up/Push-Up

601 7TH STREET SOUTH, DELANO, MINNESOTA 55328-8605 (763) 972-3391 1-888-LSI-INST (1-888-574-4678) FAX (763) 972-3185



Sports & Fitness 100058 Sit-Up/Push-Up

J:\SPECS\182\18274400.P65

Parts List

Part#	Description	Qty
102550-00	Toe Hold, Specify Color	1
168621-00	Bench Leg, Specify Color	2
153991-00	TenderTuff Bench Slat Set, Boxed	1
153993-00	Bench Slat, Specify Color	2
182761-00	Hardware Package	1
100327-00	3/8" Standard Hex Nut, SST	8
100362-00	3/8" Flat Washer, SST	8
100198-00	3/8" x 1 1/8" BHCS w/Pin, SST	8
115176-00	ASTM HD Surface Warning Label	1
182212-00	Entanglement Warning Label	1
182213-00	Hot Surface Warning Label	1
156847-00	Play It Safe Label, 5-12 Yrs.	1
162234-00	Sit-Up Hardware Package	1
100198-00	3/8" x 1 1/8" BHCS w/Pin, SST	2
100327-00	3/8" Standard Hex Nut, SST	2
100365-00	3/8" SAE Flat Washer, SST	4

Specifications

Bench: Flanged formed from 12 Ga (.105") sheet steel conforming to ASTM A1011. Seating surface is perforated with 5/16" diameter holes. Finish: TenderTuff, color specified.

Toe Hold: Weldment comprised of formed 1.029" O.D. RS-20 (.070"-.080") galvanized steel tubing and 1/4" x 2" x 13 1/2" HR flat plate. Finish: ProShield, color specified.

Bench Legs: Weldment comprised of 2 3/8" O.D. RS20 (.095"-.105") galvanized steel tubing and 3/8" x 4" mounting plate. Finish: ProShield, color specified.

Fasteners: Primary fasteners shall be socketed and pinned tamperproof in design, stainless steel (SST) per ASTM F 879 unless otherwise indicated (see specific product installation/specifications).

Installation Time: Approx. 1 man hour

Concrete Req.: Approx. 2 cu. ft.

Weight: 90 lbs.

Sign - 35 lbs.

Installation Instructions

- 1) Attach TenderTuff slats to frames, as shown using 3/8" standard hex nuts with flat washers and 3/8" x 1 1/8" BHCS w/pin.
- 2) Attach toe hold as shown using 3/8" x 1 1/8" BHCS w/pin with 3/8" SAE flat washers and 3/8" standard hex nuts with 3/8" SAE flat washers.
- 3) Dig footings holes, spaced as shown. Set assembled bench in footing holes and prop plumb and level position. Pour concrete footings and let cure for a minimum of 72 hours before using.
- 4) Apply labels.

Holmes Run Park

Add Picnic Table



Kiosk



To the Path to N. Pickett St.

To the Beatley Bridge, Duke St.

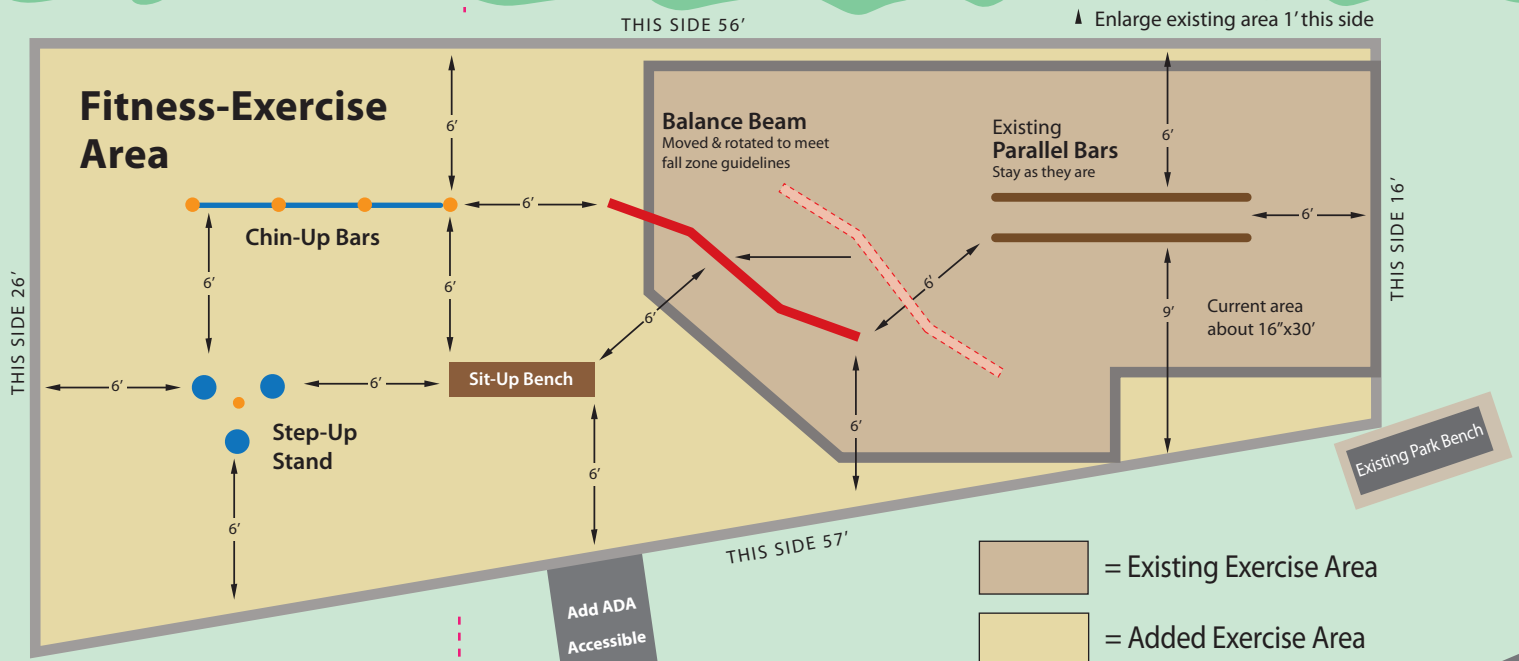

TITLE	FITNESS-EXERCISE AREA		
LOCATION	HOLMES RUN PARK (PICKETT ST. & BEATLEY BRIDGE INTERSECTION)		
SCALE	1/8" = 1'		
DATE	03/29/12	VERSION	3D
LAYOUT	MARQUIS GRAPHIC DESIGN ASSOCIATES, ALEXANDRIA, VA 703 519-7916		

Proposed Enlargement of the Holmes Run Park Exercise Area

Support letters and sheets of signatures also showing project support.

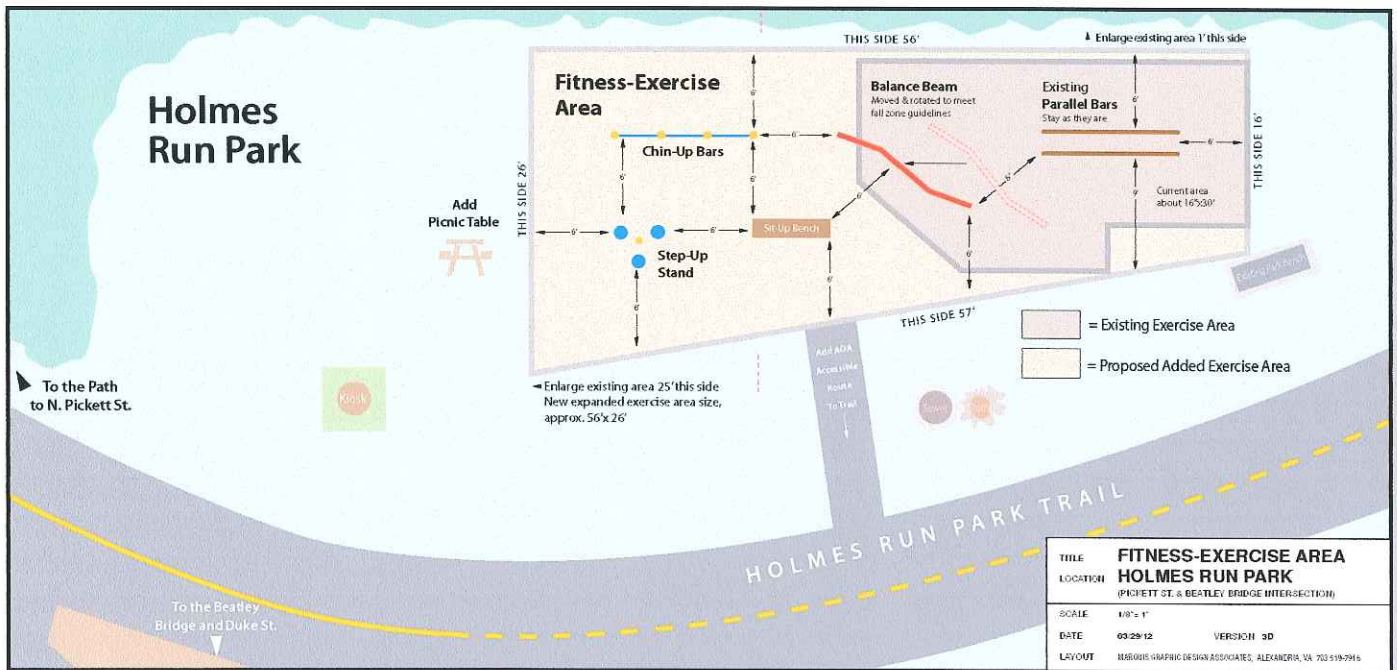



Holmes
Run
Park
Committee

ALEXANDRIA, VIRGINIA

May 15, 2012

Dear Ms. Judy Lo and Ms. Laura Durham,

Enclosed are sheets with 150+ community resident signatures supporting the plan to expand the current exercise area in Holmes Run Park and replace 3 pieces of exercise equipment. These are an addendum to the Citizen Project Request form and materials submitted by the Holmes Run Park Committee on March 30, 2012.

The signatures affirm wide community support for this project. Everyone who signed was shown details of the proposal and expressed enthusiastic support of the plan. Many who signed are regular park users and look forward to using an expanded fitness area. This was confirmed last Wednesday, May 9th when park patrons were already using the parallel bars and balance beam within 24 hours of their rehab renovation.

Fitness and exercise are an important part of the lives of many area residents. We know more than ever the benefits of fitness and good health and the alarming media information regarding the rise of obesity and its associated negative health impacts. President and Mrs. Michele Obama are currently promoting PALA, the Presidential Active Lifestyle Awards; that promotes physical activity and good nutrition. Anything that promotes and encourages physical activity is a benefit to everyone, including the community.

While playgrounds promote fun, exercise and physical activity for the young, it is equally important to have places for adults to continue positive exercise routines. The exercise area as proposed provides a place where young and old can practice positive and healthy activity. This is an appropriate use of Holmes Run park space and an excellent use of city resources. This is an investment that will pay dividends through a more healthful community for years to come.

We hope you approve this worth while and beneficial proposal and thank you for the opportunity to suggest this improvement and restoration to the park.

Respectfully yours,

Elizabeth Wright

Holmes Run Park Committee chair



Brookville-Seminary Valley Civic Association

BSVCA, P.O. Box 23348, Alexandria, Virginia 22304 • info@bsvca.net

To: Commissioners, Alexandria Park and Recreation Commission
James Spengler, Director, Recreation, Parks and Cultural Activities, City of
Alexandria

Subject: Exercise Equipment in Holmes Run Park

Date: May 16, 2012

At its meeting last night, the Board of the Brookville-Seminary Valley Civic Association (BSVCA) unanimously voted in favor of the proposal of the Holmes Run Park Committee to expand the current exercise area in Holmes Run Park, and to add three pieces of exercise equipment. The Board strongly supports this proposal, a good investment for the city which will provide long-term benefits to a wide variety of members of the community.

The expanded exercise area, as proposed, with the new pieces of equipment, would increase the number of people, of all ages, who would choose to exercise in the park. May is National Physical Fitness and Sports Month, where individuals and organizations nationwide are promoting the value of physical activity. That makes this a perfect time to expand the exercise opportunities that the City provides its citizens.

We urge the City and the Park and Recreation Commission to approve this expansion of exercise opportunities in our neighborhood.

John Broughton
President, Brookville-Seminary Civic Association

4/21/2012

1 of 4

Proposed Enlargement of Park Exercise Area

The Holmes Run Park Committee has submitted an application to the Department of Parks and Recreation for the replacement of exercise equipment, and the expansion of the existing exercise area to include the 3 pieces of equipment: **Chin-Up bars, Step-Up Steps and a Sit-Up bench.** If you live in Alexandria and would like to see this exercise area expanded, and the replacement of those pieces of equipment, please sign this sheet which will be submitted in support of our application.

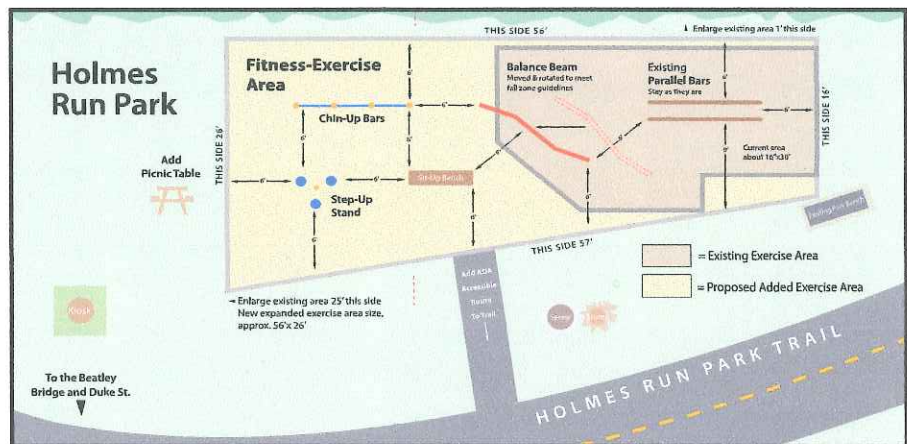

NAME Printed	NAME Signature	ADDRESS	ZIP
1 RUTH ROUSH	Ruth Roush	200 N. Pickett Alexandria, VA	22304
2 CONVERSE WEST	Converse West	200 N. PICKETT ALEX, VA	22304
3 BRUCE DWYER	Bruce D. Dwyer	915 BERNARD	22314
4 David Colton	David Colton	100 Wynwood	22312
5 W. DICKINSON	W. Dickinson	805 Ponce	22302
6 BRUCE DEARY	Bruce C. Deary	317 N Howard	22304
7 Chris von Schoening	Chris von Schoening	36 Underwood	22304
8 Amos Desjardins	Amos Desjardins	719 So. Alfred St	22314
9 Carolyn Grigliore	Carolyn Grigliore	1416 N. Thacker St.	22304
10 Norma Fossum	Norma Fossum	200 N. P. de la H St #11	22304
11 Chris Hill	Chris Hill	106 1/2 Harvard	22314
12 Mike Serrano	Mike Serrano	4951 Bierman Pk Dr. #205	22304
13 Michael Flores	Michael Flores	501 Cameron Station Blvd	22304
14 Sue Kalman	Sue Kalman	200 W. Pickett	22304
15 Ericka Delgado	Ericka Delgado	656 N. Ripley St.	22304
16 Adrian Delgado	Adrian Delgado	656 N. Ripley St	22304
17 Betsy Riffi	Betsy Riffi	621 N St Asaph	22314
18 Lauren Meinhardt	Lauren Meinhardt	1340 Holmes Run	22304
19 Gabriel Gonzalez	Gabriel Gonzalez	200 S. Whittier St Alexandria, VA	22304
20 Beverly Parker	Beverly Parker	2327 Duke St	22314

Alex

04

3064

Proposed Enlargement of Park Exercise Area

The Holmes Run Park Committee has submitted an application to the Department of Parks and Recreation for the replacement of exercise equipment, and the expansion of the existing exercise area to include the 3 pieces of equipment: **Chin-Up bars, Step-Up Steps and a Sit-Up bench.** If you live in Alexandria and would like to see this exercise area expanded, and the replacement of those pieces of equipment, please sign this sheet which will be submitted in support of our application.

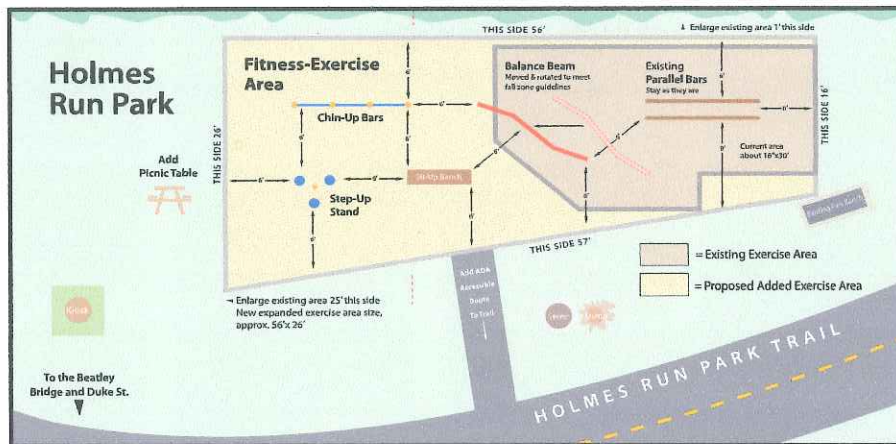

NAME Printed	NAME Signature	ADDRESS	ZIP
1 SORAYA YUNUS	<i>Soraya Yunus</i>	5500 HOLMES RUN BLVD #610	22304
2 Both Caseman	<i>B. Caseman</i>	5257 Col. Johnson Lane Alex	22304
3 Francis Zambrano	<i>Francis Zambrano</i>	455 N. Armistead #3 Alex	22312
4 Roberta Aldana	<i>Roberta Aldana</i>	455 N. Armistead #3 Alex	22312
5 Amber Waller	<i>Amber Waller</i>	314 N. FAIRFAX ST.	22314
6 Andrea DaSouza	<i>Andrea DaSouza</i>	314 N. Fairfax St	22314
7 Clara Waller	<i>Clara Waller</i>		
8 Michelle Tello	<i>Michelle Tello</i>	3001 Park Center Dr. #308 Alex	VA 22302
9 Deborah Lucey	<i>Deborah Lucey</i>	328 Helmuth Ln	22304
10 Chris Gabriel	<i>CHRIS GABRIEL</i>	1155 9th St	22204
11 Stacy Hoeflich	<i>Stacy Hoeflich</i>	4701 Care Dr. Alex	22310
12 PAUL WILSON	<i>Paul Wilson</i>	266 GRETHER ST. ALEX	22304
13 Amanda Robinson	<i>Amanda Robinson</i>	400 Cameron Station Blvd	22304
14 Jeff Malcolm	<i>Jeff Malcolm</i>	5125 DONOVAN DR	22304
15 MASUD	<i>Masud</i>	5742 DEADEN AVE APT-172	
16 Karen DeGrado	<i>Karen DeGrado</i>	4918 Gardner Dr	22304
17 Jennie DeTillio	<i>Jennie DeTillio</i>	220 C ST NE D.C.	
18 Sam Binkley	<i>Sam Binkley</i>	5905 Cooverdale Way E	22310
19 Daniel Sherwood	<i>Daniel Sherwood</i>	2016 Stargrass Ct	22192
20 Erin May	<i>Erin May</i>	1233 Madison Ln	22192

4/21/2012

4 of 4

Proposed Enlargement of Park Exercise Area

The Holmes Run Park Committee has submitted an application to the Department of Parks and Recreation for the replacement of exercise equipment, and the expansion of the existing exercise area to include the 3 pieces of equipment: **Chin-Up bars, Step-Up Steps and a Sit-Up bench.** If you live in Alexandria and would like to see this exercise area expanded, and the replacement of those pieces of equipment, please sign this sheet which will be submitted in support of our application.

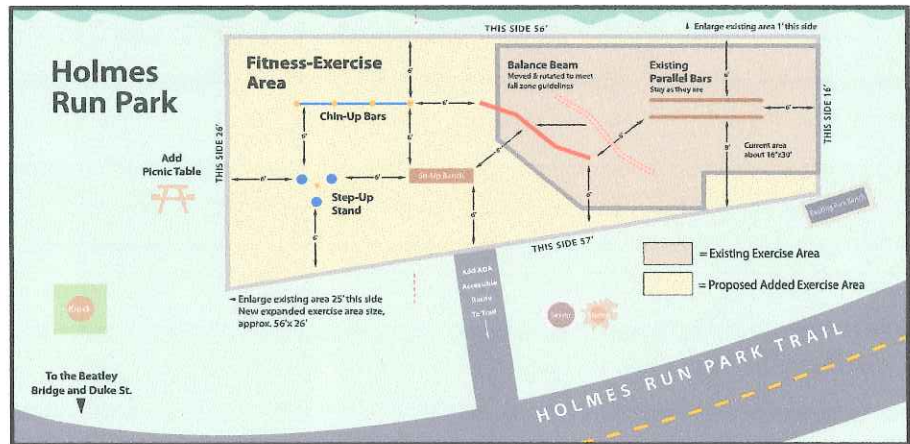

NAME Printed	NAME Signature	ADDRESS	ZIP
1 <u>Joelle Jordan</u>	<u>[Signature]</u>	<u>4044 Vocatum Lane</u>	<u>22307</u>
2 <u>Del Pepper</u>	<u>[Signature]</u>	<u>4600 Duke</u>	<u>22304</u>
3 <u>Marlene Dakita</u>	<u>[Signature]</u>	<u>200 N. Pickett St #1410</u>	<u>22304</u>
4 <u>VON LAMBERT</u>	<u>[Signature]</u>	<u>2600 Kesler Ave</u>	<u>22301</u>
5 <u>E. M. Mitchell</u>	<u>[Signature]</u>	<u>7505 Gresham</u>	<u>22151</u>
6 <u>Mary Clark-Hagan</u>	<u>[Signature]</u>	<u>4678 Strathblane</u>	<u>22304</u>
7 <u>MARIE EISHAFA</u>	<u>[Signature]</u>	<u>346 Claude Mill Dr.</u>	<u>22304</u>
8 <u>Sara Aly</u>	<u>[Signature]</u>	<u>346 Claude Mill Dr</u>	<u>22304</u>
9 <u>DANIA IMR</u>	<u>[Signature]</u>	<u>657 S Columbus</u>	<u>22314</u>
10 <u>Allison Silberberg</u>	<u>[Signature]</u>	<u>1544 Mt. Eagle Pl.</u>	<u>22302</u>
11 <u>Michael Poliakoff</u>	<u>[Signature]</u>	<u>1412 Oakcrest Dr</u>	<u>22302</u>
12 <u>Eleonora Gafur</u>	<u>[Signature]</u>	<u>200 N Pickett St</u>	<u>22304</u>
13 <u>SULIA WILLIAMS</u>	<u>[Signature]</u>	<u>200 N Pickett St #1209</u>	<u>22304</u>
14 <u>Andrea Dier</u>	<u>[Signature]</u>	<u>505 Robinson Ct</u>	<u>22302</u>
15 <u>Bette Jo Sullivan</u>	<u>[Signature]</u>	<u>1022 N. Pelham St</u>	<u>22304</u>
16 <u>Jounsard A. Van Fleet</u>	<u>[Signature]</u>	<u>20 Wolfest</u>	<u>22314</u>
17 <u>Georgia K. Cannady</u>	<u>[Signature]</u>	<u>20 East Oak St</u>	<u>22301</u>
18 <u>Joanne Lepore</u>	<u>[Signature]</u>		
19 <u>John GOSTWA</u>	<u>[Signature]</u>	<u>108 S. Fayette</u>	<u>22314</u>
20 <u>Geoffrey M. Goodale</u>	<u>[Signature]</u>	<u>493 Naylor Pl.</u>	<u>22304</u>

Proposed Enlargement of Park Exercise Area

The Holmes Run Park Committee has submitted an application to the Department of Parks and Recreation for the replacement of exercise equipment, and the expansion of the existing exercise area to include the 3 pieces of equipment: **Chin-Up bars**, **Step-Up Steps** and a **Sit-Up bench**. If you live in Alexandria and would like to see this exercise area expanded, and the replacement of those pieces of equipment, please sign this sheet which will be submitted in support of our application.

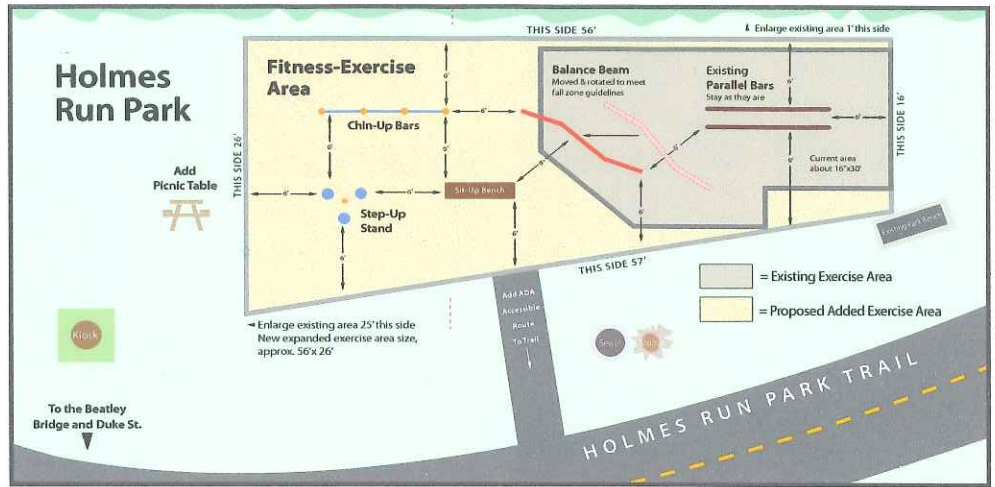

NAME Printed	NAME Signature	ADDRESS	ZIP
1 John P. Felt	[Signature]	330 N. Pickett St. Alexandria, VA	22304
2 JOHN T. BURCH, JR.	[Signature]	1015 N. Pelham St. Alexandria	22304
3 William J. Sullivan	[Signature]	1022 N. Pelham St.	
4 Betty Jo Sullivan	[Signature]	1022 N. Pelham St.	22304
5 Sara Doering	[Signature]	612 N. Pegram St	22304
6 J. STEPHEN RAMEY	[Signature]	1036 N. PELHAM ST.	22304
7 KATHLEEN BURNS	[Signature]	1036 N. PELHAM ST.	22304
8 Desnee Jessamy	[Signature]	704 N. Pelham St. Alex.	22304
9 CAROL JAMES	[Signature]	1000 N Vail St Alex	22304
10 Geoffrey M. Goodale	[Signature]	493 Naylor Pl.	22304
11 Shirley Downs	[Signature]	1007 North Vail	22304
12 JANICE MAGNUSON	[Signature]	905 PEELE PLACE	22304
13 MARILYN HYDE	[Signature]	620 N. Pegram St.	22304
14 KEITH KRUSE	[Signature]	309 N LANGLEY ST	22304
15 Elizabeth Richardson	[Signature]	327 N Pickett St.	22304
16 Jordan Ortiz	[Signature]	5388 Taney Ave	22304
17 JIM BROUGHTON	[Signature]	5367 Holmes Run Pkwy	22304
18 JUDY COOPER	[Signature]	6001 N Van Dam	22304
19 Christel Ribble	[Signature]	4124 Duxbury	
20 MARGARET HASBOD	[Signature]	332 N Pickett St	22304

Proposed Enlargement of Park Exercise Area

The Holmes Run Park Committee has submitted an application to the Department of Parks and Recreation for the replacement of exercise equipment, and the expansion of the existing exercise area to include the 3 pieces of equipment: **Chin-Up bars, Step-Up Steps and a Sit-Up bench.** If you live in Alexandria and would like to see this exercise area expanded, and the replacement of those pieces of equipment, please sign this sheet which will be submitted in support of our application.

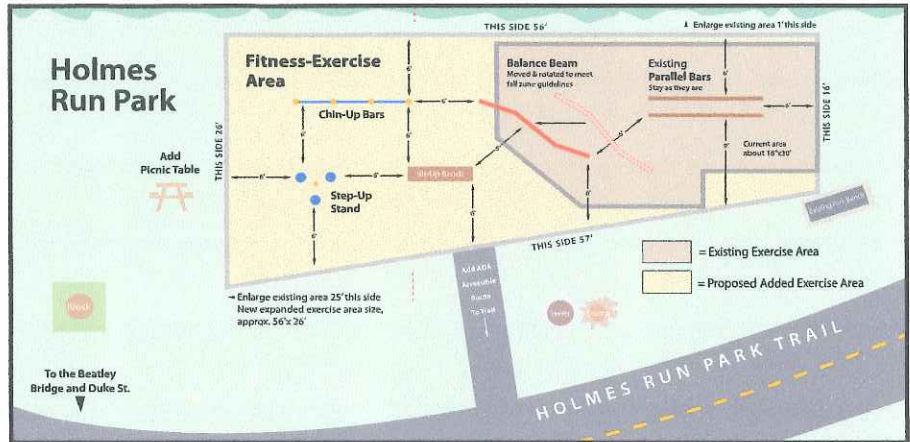

NAME Printed	NAME Signature	ADDRESS	ZIP
1 PAUL T. FERRARO	<i>Paul Ferraro</i>	5300 Holmes Run Pkwy Alex, VA	22304
2 LAWRENCE CLEMENS	<i>Lawrence Clemens</i>	5300 HOLMES RUN PKWY ALEXANDRIA, VA	22304
3 JUDITH THOMPSON	<i>Judith Thompson</i>	5300 HOLMES RUN PKWY	22304
4 Edward Bernier	<i>Edward Bernier</i>	5300 " " #515	22304
5 MARY ANN BARIUSKI	<i>Mary Ann Bariuski</i>	5300 Holmes Run Pkwy #1109	22304
6 D. FARAY	<i>D. Faray</i>	" "	" "
7 Paul J. May	<i>Paul J. May</i>	5300 Holmes Run Pkwy #113	Alex VA 22304
8 Adam Bing	<i>Adam Bing</i>		
9 Meg	<i>Meg</i>	5300 Holmes Run Pkwy	22304
10 Edith Houston	<i>Edith Houston</i>	5300 Holmes Run Pkwy	22304
11 Heather Y. Sliwka	<i>Heather Y. Sliwka</i>	5300 Holmes Run Pkwy,	22304
12 Duane Tolleksen	<i>Duane Tolleksen</i>	5300 Holmes Run Pkwy #107	22304
13 JENNIFER J. FRAY	<i>Jennifer J. Fray</i>	5300 Holmes Run Parkway	22304
14 Suzanne Brook	<i>Suzanne Brook</i>	Alex VA	22304
15 Petronilla BRENDA	<i>P. Breahe</i>	5300 Holmes Run Pkwy, #405	Alex, VA.
16 Debra M. Ramsey	<i>Debra M. Ramsey</i>		
17 Dee Kretsch	<i>Dee Kretsch</i>	5300 Holmes # 1116	Alex VA 22304
18 Mark Lattal	<i>Mark Lattal</i>	5300 Holmes Run #309	Alex VA 22304
19			
20			

Proposed Enlargement of Park Exercise Area

The Holmes Run Park Committee has submitted an application to the Department of Parks and Recreation for the replacement of exercise equipment, and the expansion of the existing exercise area to include the 3 pieces of equipment: **Chin-Up bars, Step-Up Steps and a Sit-Up bench.** If you live in Alexandria and would like to see this exercise area expanded, and the replacement of those pieces of equipment, please sign this sheet which will be submitted in support of our application.

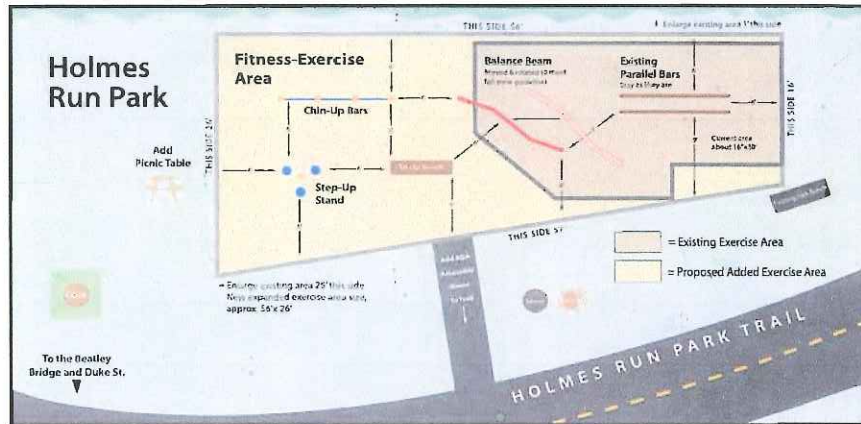

NAME Printed	NAME Signature	ADDRESS	ZIP
1 Elizabeth Wright	<i>Elizabeth Wright</i>	113 S Ingram	22304
2 ROGER WAUD	<i>Roger Waud</i>	501 Alabaster Dr #1203	22314
3 JORDAN MORHEWSTERN	<i>Jordan Morhewstern</i>	133 Delta Street	22304
4 Jeanne GARDNER	<i>Jeanne Gardner</i>	105 Grottnagreen Pt	22304
5 R. LYN HOUL	<i>R. Lynn Houll</i>	238 So. Jefferson St	
6 RAYMOND ZOETER	<i>R. Zoeter</i>	523 N. AAXTON ST.	22304
7 Angela Doty	<i>Angela Doty</i>	391 Cameron Station Blvd	22304
8 Boyd W. Walker	<i>Boyd W. Walker</i>	1307 King St	22314
9 Tessa Reed	<i>Tessa Reed</i>	1307 King St	22314
10 Mark Conkr	<i>Mark Conkr</i>	484 N. Pickett St.	22304
11 JEFF BERNHOLZ	<i>Jeff Bernholz</i>	4708 RICHMURR	22304
12 BRIAN MARQUIS	<i>Brian Marquis</i>	332 N. PICKETT ST.	22304
13 Hallie Fivecoat	<i>Hallie Fivecoat</i>	5336 Thayer Ave	22304
14 Allison Silberberg	<i>Allison Silberberg</i>	1544 Mt. Eagle Pl.	22302
15 Sam Wls	<i>Sam Wls</i>	486 N. PICKETT	22304
16 JOHN HENDRIXSON	<i>John Hendrixson</i>	483 N. PICKETT	22304
17			
18			
19			
20			

PLEASE SIGN Proposed Enlargement of Park Exercise Area

The Holmes Run Park Committee has submitted an application to the Department of Parks and Recreation for the replacement of exercise equipment, and the expansion of the existing exercise area to include the 3 pieces of equipment: **Chin-Up bars, Step-Up Steps and a Sit-Up bench.** If you live in Alexandria and would like to see this exercise area expanded, and the replacement of those pieces of equipment, please sign this sheet which will be submitted in support of our application.

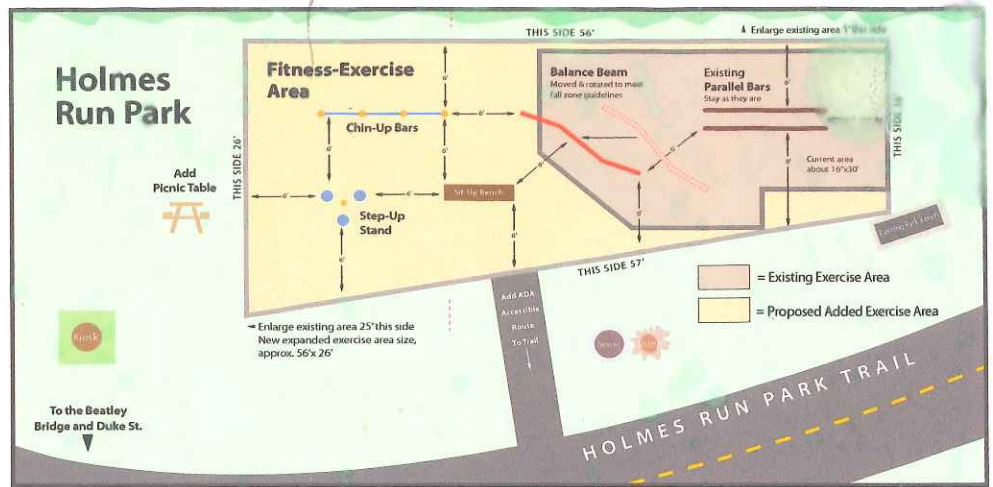

NAME Printed

NAME Signature

ADDRESS

ZIP

1	ELIZABETH SMITH	Elizabeth Smith	5300 HOLMES RUN PENTON	22304
2	Eric Sokolove	Eric Sokolove	4708 Sully Place	22304
3	ROBERT JIMENEZ	[Signature]	24 cantebury sq	
4	K STEVENSON	[Signature]	14 cantebury lane	
5	ISSEAUERS	[Signature]	500 PERRYMAN PI	22304
6	SUSAN DONNA	[Signature]	200 N PICKETT	22304
7	BRIAN SCHEWING	[Signature]	210 W. TAYLOR RUN	22314
8	KARIN MURPHY	[Signature]	304 N. HOWARD	22304
9	Jack LeBasseur	[Signature]	145 Century Dr.	22304
10	Janice Fortunato	Janice Fortunato	200 N PICKETT ST	22304
11	DAMILE H-H-AKBARI	Damileh-H Akbari	5380 HOLMES RUN	22304
12	Bishay G. Bishay	B Bishay	5500 Holmes Run	22304
13	Tony Negrete	Tony Negrete	5405 DUKES ST #408	22304
14	Marian Negrete	Marian Negrete	5405 DUKES ST #408	22304
15	Omni Moore	Omni Moore	4530 RALEIGH	22304
16	Ben Durar	[Signature]	250 S WHITING ST #110	22304
17	GERGIE SEIPLE	Gergie Seiple	250 S. PENWOLD ST	22304
18	VINH DUONG	Vinh Duong	112 INGLE PL	22304
19	Frank Faragasso	Frank Faragasso	495 N PICKETT	22304
20				

Proposed Enlargement of Park Exercise Area

The Holmes Run Park Committee has submitted an application to the Department of Parks and Recreation for the replacement of exercise equipment, and the expansion of the existing exercise area to include the 3 pieces of equipment: **Chin-Up bars, Step-Up Steps and a Sit-Up bench.** If you live in Alexandria and would like to see this exercise area expanded, and the replacement of those pieces of equipment, please sign this sheet which will be submitted in support of our application.

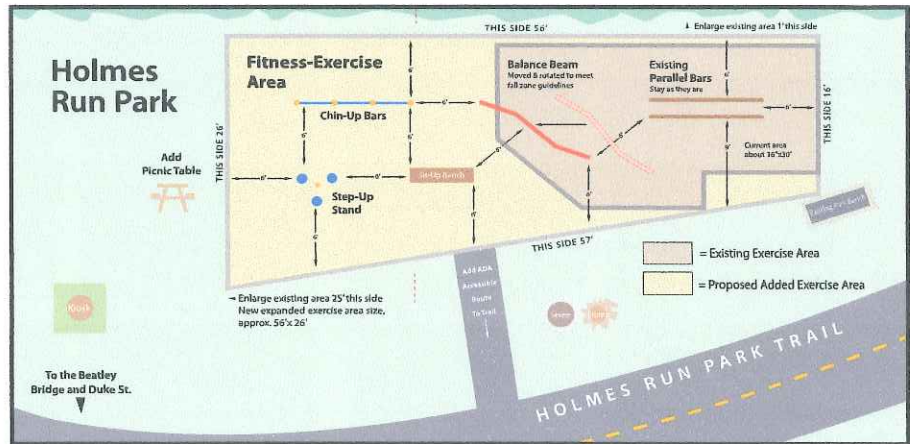

NAME Printed	NAME Signature	ADDRESS	ZIP
1 _____	_____	_____	_____
2 _____	_____	_____	_____
3 _____	_____	_____	_____
4 _____	_____	_____	_____
5 _____	_____	_____	_____
6 _____	_____	_____	_____
7 _____	_____	_____	_____
8 _____	_____	_____	_____
9 _____	_____	_____	_____
10 _____	_____	_____	_____
11 _____	_____	_____	_____
12 _____	_____	_____	_____
13 _____	_____	_____	_____
14 _____	_____	_____	_____
15 _____	_____	_____	_____
16 _____	_____	_____	_____
17 _____	_____	_____	_____
18 _____	_____	_____	_____
19 _____	_____	_____	_____
20 _____	_____	_____	_____



Active Rec CFMP Projects

Monday, May 14, 2012

Parks, Recreation + Cultural Activities

FY	Project Name	Project Code	Facility Name	Priority	Status	% Complete	Antipated Cost
FY 2013	Windows Repairs - Glazing - Replace Insulated Glass Panels	BB-13-01	Ben Brenman Park Buildings	5.) Moderate: Other (See Remarks)	On Hold	-0-	\$42,000.00
FY 2012	Replace A/C Unit	BF-12-01	Buddie Ford Center	1) Urgent: Health/Safety/Welfare	Under Warranty Period	Completed	
FY 2013	Replace Fan Coil Unit	CB-13-01	Charles Barrett Center	8) Low: Other (See Remarks)	In Queue (Outlying FY)	-0-	\$4,500.00
FY 2013	Water Damage Repairs (N. & S. walls)	CB-13-02	Charles Barrett Center	5.) Moderate: Other (See Remarks)	On Hold	-0-	\$1,200.00
FY 2013	Investigate & Repair/Replace Skylight Leaks	CB-13-03	Charles Barrett Center	5.) Moderate: Other (See Remarks)	On Hold	-0-	\$1,500.00
FY 2014	Interior Finishes	CB-14-01	Charles Barrett Center	4) Moderate: Quality of Function	In Queue (Outlying FY)	-0-	\$75,000.00
FY 2015	Replace fitness equipment with new	CB-14-01	Charles Barrett Center	4) Moderate: Quality of Function	In Queue (Outlying FY)	-0-	\$40,000.00
FY 2012	Replace exterior gym doors	CK-12-01	Cora Kelly Center	4) Moderate: Quality of Function	Preliminary Phase	-0-	\$48,104.00
FY 2012	Replace shower dividers	CK-12-02	Cora Kelly Center	4) Moderate: Quality of Function	Preliminary Phase	-0-	\$55,480.00
FY 2012	Replace gym flooring	CK-12-03	Cora Kelly Center	4) Moderate: Quality of Function	RFQ/Bids Sent Out	-0-	\$69,700.00
FY 2012	Paint gym interior wall surfaces	CK-12-04	Cora Kelly Center	4) Moderate: Quality of Function	RFQ/Bids Sent Out	-0-	\$3,750.00

FY	Project Name	Project Code	Facility Name	Priority	Status	% Complete	Antipated Cost
FY 2013	Replace Gym Floor	CK-13-01	Cora Kelly Center	5.) Moderate: Other (See Remarks)	Preliminary Phase	-0-	\$15,000.00
FY 2014	HVAC Controls	CK-14-02	Cora Kelly Center	3) Urgent: Other (See Remarks)	In Queue (Outlying FY)	-0-	\$60,000.00
FY 2014	Replace one small and two large RTU's	CK-14-1	Cora Kelly Center	3) Urgent: Other (See Remarks)	In Queue (Outlying FY)	-0-	\$160,000.00
FY 2015	Lobby Floor Finish Replacement	CK-15-01	Cora Kelly Center	4) Moderate: Quality of Function	In Queue (Outlying FY)	-0-	\$50,000.00
FY 2012	Water leak in basement Storage Room and Boiler Room	CN-12-01	Chinquapin Park Rec Center	1) Urgent: Health/Safety/Welfare	Preliminary Phase	-0-	\$50,000.00
FY 2012	Locker Room Renovations: Replace water cooler.	CN-12-02	Chinquapin Park Rec Center	4) Moderate: Quality of Function	On Hold/Delayed	-0-	
FY 2012	Replace existing HM doors	CN-12-03	Chinquapin Park Rec Center	1) Urgent: Health/Safety/Welfare	Under Warranty Period	Completed	
FY 2012	Loading dock	CN-12-04	Chinquapin Park Rec Center	4) Moderate: Quality of Function	Under Warranty Period	Completed	
FY 2012	Cubicle shelving for pool area	CN-12-05	Chinquapin Park Rec Center	4) Moderate: Quality of Function	Const'n In Progress	75%	\$15,100.00
FY 2012	Cabinetry work	CN-12-06	Chinquapin Park Rec Center	4) Moderate: Quality of Function	Final Completion/Punch List	90%	\$2,500.00
FY 2012	Replace shower diverters, new tile work, replace shower heads.	CN-12-07	Chinquapin Park Rec Center	5) Moderate: Economy of Scale	Under Warranty Period	Completed	
FY 2013	New Ceiling/Lighting in Locker Rooms, Life Guard & Pool Office, & Fitness Rooms	CN-13-02	Chinquapin Park Rec Center	5.) Moderate: Other (See Remarks)	On Hold	-0-	\$33,000.00

FY	Project Name	Project Code	Facility Name	Priority	Status	% Complete	Antipated Cost
FY 2014	Lockers in Pool Office, Ph I	CN-14-01	Chinquapin Park Rec Center	5.) Moderate: Other (See Remarks)	In Queue (Outlying FY)	-0-	\$20,470.00
FY 2014	Windows Repair-Glazing	CN-14-02	Chinquapin Park Rec Center	3) Urgent: Other (See Remarks)	In Queue (Outlying FY)	-0-	\$67,200.00
FY 2015	Windows Repair-Glazing	CN-15-01	Chinquapin Park Rec Center	3) Urgent: Other (See Remarks)	In Queue (Outlying FY)	-0-	\$67,200.00
FY 2015	Lockers in Pool Office, Ph. 2	CN-15-02	Chinquapin Park Rec Center	6) Moderate: Other (See Remarks)	In Queue (Outlying FY)	-0-	\$120,000.00
FY 2012	Roof and Gutter replacement	CO-12-01	Colasanto Arts Center	6) Moderate: Other (See Remarks)	Under Warranty Period	Completed	
FY 2012	Miscellaneous plumbing	CO-12-02	Colasanto Arts Center	1) Urgent: Health/Safety/Welfare	Under Warranty Period	Completed	
FY 2012	Vapor barrier installation	DU-12-01	Oswald Durant Arts Center	4) Moderate: Quality of Function	Ready to Commence	-0-	\$8,330.00
FY 2013	Decommission AC Units	DU-13-01	Oswald Durant Arts Center	5.) Moderate: Other (See Remarks)			\$40,000.00
FY 2014	Stage Lighting System	DU-14-02	Oswald Durant Arts Center	3.) Moderate: Quality of Function	Preliminary Phase		\$50,000.00
FY 2014	Auditorium Floor Lighting - Security	OD-14-01	Oswald Durant Arts Center	4) Moderate: Quality of Function	In Queue (Outlying FY)	-0-	
FY 2014	Fabric Acoustic Panels	OD-14-03	Oswald Durant Arts Center	4) Moderate: Quality of Function	In Queue (Outlying FY)	-0-	\$10,000.00
FY 2015	New Flooring in Corridor	OD-15-01	Oswald Durant Arts Center	4) Moderate: Quality of Function	In Queue (Outlying FY)	-0-	\$16,562.00
FY 2015	New Flooring and Wall base	OD-15-02	Oswald Durant Arts Center	4) Moderate: Quality of Function	In Queue (Outlying FY)	-0-	\$15,000.00
FY 2012	Complete ACT Suspended Ceiling	FM-12-01	Four Mile Run Community Center	4) Moderate: Quality of Function	100% Completed	Completed	

FY	Project Name	Project Code	Facility Name	Priority	Status	% Complete	Antipated Cost
FY 2012	Exterior Stage	FM-12-02	Four Mile Run Community Center	4) Moderate: Quality of Function	100% Completed	Completed	
FY 2012	Replace two HVAC system compressors	LC-12-01	Lee Center	1) Urgent: Health/Safety/Welfare	Const'n In Progress	25%	\$25,000.00
FY 2012	Building Assessment	LC-12-02	Lee Center	3) Urgent: Other (See Remarks)	Preliminary Phase	-0-	\$15,000.00
FY 2014	Millwork Replacement (Multiple Areas)	LC-14-01	Lee Center	3.) Moderate: Quality of Function	Preliminary Phase	-0-	\$10,000.00
FY 2014	Replace Cabinets in Kitchen	LC-14-02	Lee Center	3.) Moderate: Quality of Function	Preliminary Phase	-0-	\$15,000.00
FY 2015	Replace Corridor Water Cooler	LC-15-01	Lee Center	3.) Moderate: Quality of Function	Preliminary Phase	-0-	
FY 2015	Fenestration System Replacement	LC-15-02	Lee Center	6) Moderate: Other (See Remarks)	In Queue (Outlying FY)	-0-	
FY 2015	Restrooms Wall covering Replacement	LC-15-03	Lee Center	4) Moderate: Quality of Function	In Queue (Outlying FY)	-0-	
FY 2013	Paint Gym	MV-13-01	Mt. Vernon Center	3.) Moderate: Quality of Function	Preliminary Phase	-0-	\$3,500.00
FY 2013	Kitchen Renovations	MV-13-02	Mt. Vernon Center	3.) Moderate: Quality of Function	Preliminary Phase	-0-	\$15,000.00
FY 2014	HVAC System Replacement	MV-14-01	Mt. Vernon Center	3) Urgent: Other (See Remarks)	In Queue (Outlying FY)	-0-	\$25,000.00
FY 2014	Activity Room Ceiling Replacement	MV-14-02	Mt. Vernon Center	4) Moderate: Quality of Function	In Queue (Outlying FY)	-0-	\$20,000.00
FY 2013	Replace Millwork - New Base Cabinets & Locks	NL-13-01	Nannie J. Lee Center	3.) Moderate: Quality of Function	Preliminary Phase	-0-	\$25,000.00
FY 2014	Gym Bleacher Replacement	NL-14-01	Nannie J. Lee Center				\$11,000.00

FY	Project Name	Project Code	Facility Name	Priority	Status	% Complete	Antipated Cost
FY 2015	New Fitness Equipment	NL-15-01	Nannie J. Lee Center	4) Moderate: Quality of Function	In Queue (Outlying FY)	-0-	\$40,000.00
FY 2012	Replace front entry doors	PH-12-01	Patrick Henry Center	1) Urgent: Health/Safety/Welfare	Under Warranty Period	Completed	
FY 2012	Repair millwork and counter top at kitchen	PH-12-02	Patrick Henry Center	4) Moderate: Quality of Function	100% Completed	Completed	
FY 2012	Replace heat wheel	WR-12-01	William Ramsay Center	7) Low: On Hold or Delayed	In Queue (Outlying FY)	-0-	\$10,000.00
FY 2012	HVAC automatic control system	WR-12-02	William Ramsay Center	7) Low: On Hold or Delayed	Uner Consideration		\$10,000.00
FY 2012	Interior office alteration	WR-12-03	William Ramsay Center	4) Moderate: Quality of Function	100% Completed	Completed	
FY 2012	Replace front doors	WR-12-04	William Ramsay Center	1) Urgent: Health/Safety/Welfare	Under Warranty Period	Completed	
FY 2013	Replace Damaged Dance Floor	WR-13-01	William Ramsay Center	1.) Urgent: Health/Safety/Welfare	Preliminary Phase	-0-	\$60,000.00
FY 2013	Regrade and Re-pave exterior area to stop water intrusion.	WR-13-02	William Ramsay Center	1) Urgent: Health/Safety/Welfare	Preliminary Phase	-0-	\$50,000.00
FY 2015	New Fitness Equipment	WR-15-01	William Ramsay Center	4) Moderate: Quality of Function	In Queue (Outlying FY)	-0-	\$20,000.00
FY 2015	Install Sound Baffles	WR-15-02	William Ramsay Center	4) Moderate: Quality of Function	In Queue (Outlying FY)	-0-	\$10,000.00

City of Alexandria, Virginia

MEMORANDUM

DATE: MAY 17, 2012

TO: PARK & RECREATION COMMISSION MEMBERS

FROM: PARK PLANNING, DESIGN & CAPITAL DEVELOPMENT TEAM
RON M. KAGAWA, ASLA LEED AP DIVISION CHIEF

**SUBJECT: DANA W. WEDELES, AICP
DIVISION REPORT, ITEM V.ii.**

The purpose of this memorandum is to inform the Commission that Dana W. Wedeles of the Park Planning, Design & Capital Development Team in May 2012, successfully completed her certification requirements and examinations for induction into the American Institute of Certified Planners (AICP).

AICP credentials are the foremost mark of national distinction in rigorous standards, expertise and community service as identified by the American Planning Association. AICP is the American Planning Association's professional institute and provides recognized leadership nationwide in the certification of professional planners, ethics, professional development, planning education and the standards of planning practice.

Please join Staff in congratulating Dana's accomplishment.

###

City of Alexandria, Virginia

MEMORANDUM

DATE: MAY 17, 2012

TO: PARK AND RECREATION COMMISSION MEMBERS

FROM: CHERYL LAWRENCE, ACTING DIVISION CHIEF
MARKETING, SPECIAL EVENTS & WATERFRONT DISTRICT

SUBJECT: PARK AND RECREATION COMMISSION
MARKETING, SPECIAL EVENTS & WATERFRONT
DIVISION UPDATE - ITEM #IV-E

SPECIAL EVENTS MANAGEMENT:

The City's Special Events Committee met on Thursday, May 17 and reviewed seven events scheduled for the months – October.

The events were as follow:

Cambodian Festival – August 19

Art on the Avenue – October 6

16th Annual Halloween Parade – October 28

Old Town Doggie Walk Palooza - September 22

PTOS & FAPTO Innovation 5k – October 21

CTK 5k Fun Run – October 14

CITY MARINA Update: On May 9, the Marina piling replacement project was completed.

Eight pilings were replaced, enhancing the appearance of the Marina area.

Upcoming projects: - the electrical upgrades and facilitating improved signage on locations of restrooms after the Torpedo Factory closes at 6 p.m.

WATERFRONT DISTRICT MAINTENANCE PROJECTS UPDATES

The Waterfront Park staff participated in the “Spring for Alexandria” event, using volunteers to help clean up the parks. Over thirty volunteers signed help paint and remove lots of trash along the waterways.

Park Planning staff is working with the Founder Park Civic Association and the Founder Park Exercise Dog Group to replace trees in the Park, tree will be donated from Ruppert Nurseries.

Trees and plantings installation are included in the donation. Additional items will include a water fountain and benches at the dog exercise area. The groups are looking to move forward with tree planting this spring. See the following page for a list of Upcoming Special Events.

City of Alexandria, Virginia

MEMORANDUM

DATE: MAY 17, 2012

TO: PARK & RECREATION COMMISSION MEMBERS

FROM: PARK PLANNING, DESIGN & CAPITAL DEVELOPMENT TEAM
RON M. KAGAWA, ASLA LEED AP DIVISION CHIEF
JACK R. BROWAND, CPRP ACTING DEPUTY DIRECTOR

**SUBJECT: JONES POINT PARK; UPDATE MAY, 2012
DIRECTOR'S REPORT - ITEM V-B**

The purpose of this update is to provide an overview of activities related to Jones Point Park construction, which commenced on November 18, 2010, for the months of April-May, 2012. Project status as of May 09, indicates that 92.3 percent or 539 contract days have been expended and that the installed work is equivalent to 85.10 percent of total project completion. There is no change to the contract completion date – which remains anticipated as June 25, 2012. The Commission will be similarly updated at its regularly scheduled meetings until completion of construction.

VDOT-COMMUNITY LIAISON INFORMATION GROUP

To ensure that construction activities continue with little disruption, and to provide a forum for open dialogue with the surrounding community, the Virginia Department of Transportation (VDOT), with participation of the National Park Service and City of Alexandria, has created a Community Liaison Information Group on Jones Point Park Construction. The group is comprised of a representative from resident groups that may be most impacted by ongoing work at Jones Point Park.

The Community Liaison Information Group will meet quarterly to discuss the project and to allow for members to ask questions and to be briefed on ongoing work. The meetings are open to the public and include representatives from the project's managing parties - VDOT and the National Park Service, as well as staff from City of Alexandria. Members of the Liaison Group have been identified as direct points of contact for gathering information on neighborhood concerns or questions, and will have direct contact to VDOT to address such items as they arise.

The Community Liaison Information Group held a construction site tour on Saturday; April 28, 2012 and its last regularly scheduled Community meeting on Tuesday; May 01, 2012 at the City's Lee Center.

May 17, 2012
Page 2 of 2

ADDITIONAL & FOLLOW-UP INFORMATION

Information regarding Jones Point Park construction is continuously updated on Alexandria's Recreation, Parks & Cultural Activities department website at <http://alexandriava.gov/recreation> and VDOT's website for the Woodrow Wilson Bridge project at <http://www.wilsonbridge.com/>. These links include information regarding community meetings, construction updates and other information and resources including how citizens may stay informed by subscribing to E-News or other advisories. The Recreation, Parks & Cultural Activities website includes a continuously updated overview of construction activities for a three week look-ahead schedule of anticipated work. The most recent "Construction Schedule at a Glance" with activities related to progress for the past month is attached below.

###

**Jones Point Park Restoration Project
Construction Update at a Glance:**

Date: 05.10.2012

The following provides an overview of major tasks undertaken by the project General Contractor. Future Scheduling Week and Work Anticipated Items are subject to change in response to construction activities, weather and project conditions.

Week	Work Anticipated:
06.25.2012	Anticipated Completion (584 Contract Days)
06.18.2012	not available
06.11.2012	not available
06.04.2012	not available
05.28.2012	<u>No Work On-site May 28</u>
05.21.2012	Restricted Access Road Install fence beneath piers Place surfacing Parking Areas/Hunting Terrace Install swing arms and bollards Play Areas Place seating boulders Place topsoil Place surfacing Ship Lawn Place fence Light House Install picket fence Throughout Park Install wayfinding signs
05.14.2012	Parking Areas Place pavement Install gates Playground Install fence

Miscellaneous
Install wayfinding signs

05.07.2012 Restricted Access Road
Install fence

Royal Street
Clear curb and gutter
Place topsoil
Install vehicle barrier

Parking Areas
Place topsoil
Complete accessible ramps

Light House
Place access path
Install plantings

Reforestation Plantings
Install plants

Miscellaneous
Place foundation for rudder
Place stone in center circle

04.30.2012 Restricted Access Road
Lee Street pavement
Place conduit for vehicle barrier
Obtain electrical service

Playground
Place seating boulders
Place topsoil
Install rubber surface

Ship Lawn
Install fence

Light House
Paint well head
Finish grade yard

Reforestation Plantings
Install plants

Ballfields
Reset grades

04.23.2012 Restricted Access Road
Place topsoil between trail and parking areas

Royal Street & Hunting Towers Lot
Demolish and prepare sidewalk on West Side of Royal Street
Place sidewalk and ramps on West Side of Royal Street

Playground
Install boulders

Lighthouse
Install waterline extension
Provide mortar for brick foundation
Provide finish grade for yard area

Reforestation Plantings
Install throughout site

Comfort Station
Complete interior

04.16.2012 Restricted Access Road
Place topsoil between trail and parking areas

Royal Street & Hunting Towers Lot
Demolish and prepare sidewalk on West Side of Royal Street
Place sidewalk and ramps on West Side of Royal Street

Playground
Install boulders

Lighthouse
Install waterline extension
Provide mortar for brick foundation
Provide finish grade for yard area

Reforestation Plantings
Install throughout site

Comfort Station
Install water fountain

UPCOMING SPECIAL EVENTS:

- Bike to Work Day – **May 18**
- Tucker Trot 5k – **May 19**
- Kelly Cares 5k – **May 19**
- Colin Casey 3k/Spring Fling – **May 20**
- St. Mary's Spring Fling – **May 20**
- Childhood Cancer Awareness Walk – St Stephen St Agnes – **May 20**
- 35th Annual Memorial Day Jazz Festival – **May 28**
- Armenian Festival – **June 2**
- Youth Arts Festival - ARHA/RPCA – **June 9**
- Old Town Arts & Craft Festival – **June 16-17**
- Juneteenth Celebration - **June 16**
- Carlyle Food & Wine Festival – **June 23**
- Del Ray Music Festival – **June 23**
- 236 Annual USA/ 263th Alexandria Birthday Celebration – **July 7**
- Comcast Outdoor Film Festival – **July 13-14**
- 11th Annual Arlandria/Chirilagua Festival - **July 29**
- Irish Festival – **August 11**
- Cambodian Day Festival – **August 19**

*The City of Alexandria
Park and Recreation*

Commission

Presents the

2012 CIVIC Awards

Citizen Involved Volunteers In the Community

Deadline: Thursday, June 14, 2012

Department of Recreation, Parks and Cultural Activities
1108 Jefferson Street · Alexandria, VA 22314
www.alexandriava.gov/recreation



2012 Park and Recreation Commission CIVIC Awards

The City of Alexandria Park and Recreation Commission announces its 27th annual awards program to select and formally recognize outstanding residents who have provided a valuable service to our community in meeting recreation, park, or cultural needs. An Alexandria group, club, organization or corporate neighbor may also be nominated for an award for such service. Nominees for the award for citizen, group, club, organization, or corporate neighbor should be volunteers who have contributed time, talent or resources in an exemplary fashion. Youth nominations are encouraged. Whether the volunteer activity involves removing invasive plants, coaching youth, or providing program support at City nature and recreation centers, the CIVIC Awards recognize the special, unsung volunteer efforts of Alexandrians involved in their community. The Park and Recreation Commission invites your help in identifying those who contribute so that they may be recognized.

Timing: The awards will be presented at the Alexandria Birthday Celebration on July 7, at Oronoco Bay Park. **Nominations must be received no later than Thursday, June 14.**

Nominations should be addressed and mailed or delivered to the Park and Recreation Commission, c/o William Chesley, Deputy Director, Department of Recreation, Parks and Cultural Activities, 1108 Jefferson Street, Alexandria, VA 22314 or faxed to 703.684.6826 no later than Thursday, June 14.

Selection: Selection will be made by a special committee of the Park and Recreation Commission.

Criteria: Nominees for the CIVIC awards must reside in the City of Alexandria.

Applicable Subjects: Youth sports coaches; support of recreation programs, activities or events; parks or public open space maintenance or beautification; residents serving on special study groups or projects; cultural activities; and planning of programs and activities.

Submission Requirements: Submissions **must** include the following:

1. The nominee's name, address, and telephone number(s), or the key individual to contact if a nominee is a group, club, agency, organization or corporate neighbor.
2. Name, address, and telephone number of the person nominating the candidate.
3. A brief description (not exceeding one page) of the nominee's accomplishments and qualifications for such an award.

To submit a nomination on-line, visit <http://www3.alexandriava.gov/forms/recreation/civicawards>

For more information, call the Department of Recreation, Parks, and Cultural Activities at 703.746.4343.

2012 Park & Recreation Commission CIVIC Awards

Name of Nominee: _____

Are you submitting this nomination for a:

- Citizen (Individual) Award
- Group, Club, or Organization Award
- Corporate Neighbor Award

If nominating an individual for a Citizen Award:

Nominee's Address: _____

Nominee's Phone: (H) _____ (W) _____

If nominating a Group, Club, Organization or Corporate Neighbor Award:

Name of Group, Club, Organization or Corporate Neighbor: _____

Name of Key Contact Individual: _____

Contact's Phone: (H) _____ (W) _____

Person submitting this nomination:

Name: _____

Address: _____

Phone: _____

Complete or attach a brief description (not to exceed one page) of the nominee's accomplishments and qualifications for this award.

Applications are due by Thursday, June 14, 2012, and may be submitted:

1. Online at <http://www3.alexandriava.gov/forms/recreation/civicawards>
2. Faxed to Attn.: William Chesley at 703.684.6826
3. By Mail or In Person:

Park and Recreation Commission
c/o William Chesley, Deputy Director
1108 Jefferson Street
Alexandria, Virginia 22314

Brief Description:

DRAFT

LIST OF UPCOMING PUBLIC MEETINGS**May 17, 2012**

PLANNING & ZONING MEETINGS: For More Info. go to
<http://alexandriava.gov/Departments/Planning & Zoning>

- **View All Planning and Zoning Plans, Projects and Initiatives on their Website**
- (Beauregard Corridor Plan; BRAC:WHS at Mark Center; Four Mile Run Restoration Plan; Potomac Yards Planning and Development; Waterfront SAP, and others)
- **BEAUREGARD CORRIDOR SMALL AREA PLAN**- was approved at the City Council Public Hearing – Held May 3, 2012. For more info. go to the Planning and Zoning website.
-
- **Tuesday, June 5, 7:30 pm, Planning Commission Public Hearing – Miracle Field Lights on the docket**
- **Saturday, June 9, 10:00 a.m.- Waterfront Walk, Waterfront Commission**

DEPARTMENT OF RECREATION PARKS AND CULTURAL ACTIVITIES

For More Info. On Recreation Activities: go to <http://alexandriava.gov/Departments/Recreation>

RECREATION CENTERS MONTHLY MEETINGS:

Charles Barrett -1115 Martha Custis Drive.	3rd Thursday	7:00 pm
Charles Houston - 905 Wythe Street.	3rd Wednesday	7:00 pm
Cora Kelly-25 West Reed Avenue.	3rd Wednesday	7:00 pm
Mount Vernon- 2701 Commonwealth Avenue.	3rd Wednesday	7:00 pm
Nannie J. Lee- 1108 Jefferson Street.	2nd Monday	7:00 pm
Patrick Henry- 4643 Taney Avenue.	1st Tuesday	6:00 pm
William Ramsay- 5650 Sanger Avenue.	3rd Wednesday	6:30 pm

YOUTH SPORTS ADVISORY COUNCIL MONTHLY MEETING:

Mount Vernon Center-2701 Commonwealth Avenue. 2nd Tuesday 7:00 pm

FORT WARD AD HOC STAKEHOLDER ADVISORY GROUP 2nd Wednesday 7:00 pm

For Other-Department of Recreation Events: go to alexandriava.gov/Departments/Recreation

CITY COUNCIL SCHEDULE (Partial):

For More Info. On City Council Meetings: go to <http://alexandriava.gov/Departments/Mayor & City Council>

Date	Time	Event	Location
May 8	5:30 PM	City Council Work Session on Housing Master Plan	City Hall, Council Chambers, 301 King Street.
May 8	7:00 PM	Alexandria City Council Legislative Meeting	City Hall, Council Chambers, 301 King St.
May 12	9:30 AM	Alexandria City Council Public Hearing	City Hall, Council Chambers, 301 King St.
May 18	5:30 AM	Bike to Work Day	City Hall, Market Square
May 22	7:00 PM	Alexandria City Council Legislative Meeting	City Hall, Council Chambers, 301 King St.
May 28	8:00 AM	City Offices Closed for Memorial Day	City offices will be closed for the Memorial Day holiday.

Budget Work Sessions: The City Council approved the FY 2013 Budget on Monday, May 7, 2012.

Note: This list is not all-inclusive and is subject to change; please check appropriate City Websites to confirm information and dates or call the Department for further information.