



Waterfront Commission Flood Mitigation Subcommittee Presentation

April 5, 2021

Terry Suehr, PE, PMP, DBIA
Department of Project Implementation, Director

Matthew Landes, PLA, ISA
Department of Project Implementation, Division Chief / Waterfront Program Manager



Meeting Objectives

- ✓ Area of focus and Scope of discussion
- ✓ Baseline Project Cost vs Current CIP Funding
- ✓ Review project priorities
- ✓ Share potential alternatives under consideration based on current best practices in Resiliency Planning and Low Impact Development
- ✓ Discuss resiliency approach and alternative concepts
- ✓ Provide confidence that stormwater and climate change models are informing design to account for changing storms and climate resiliency
- ✓ Highlight next steps and anticipated timeline

Flood Characterization along the Waterfront

OVERTOPPING of Bulkhead



Requires repair and raising of bulkhead or other physical flood barrier(s).

BACKFLOW of River Outfalls



Requires backflow prevention on underground storm sewer system.

INUNDATION of Storm Sewers



Requires larger storm sewer pipes, underground storage, and pumping.

Schematic Design Endorsed by Waterfront Commission



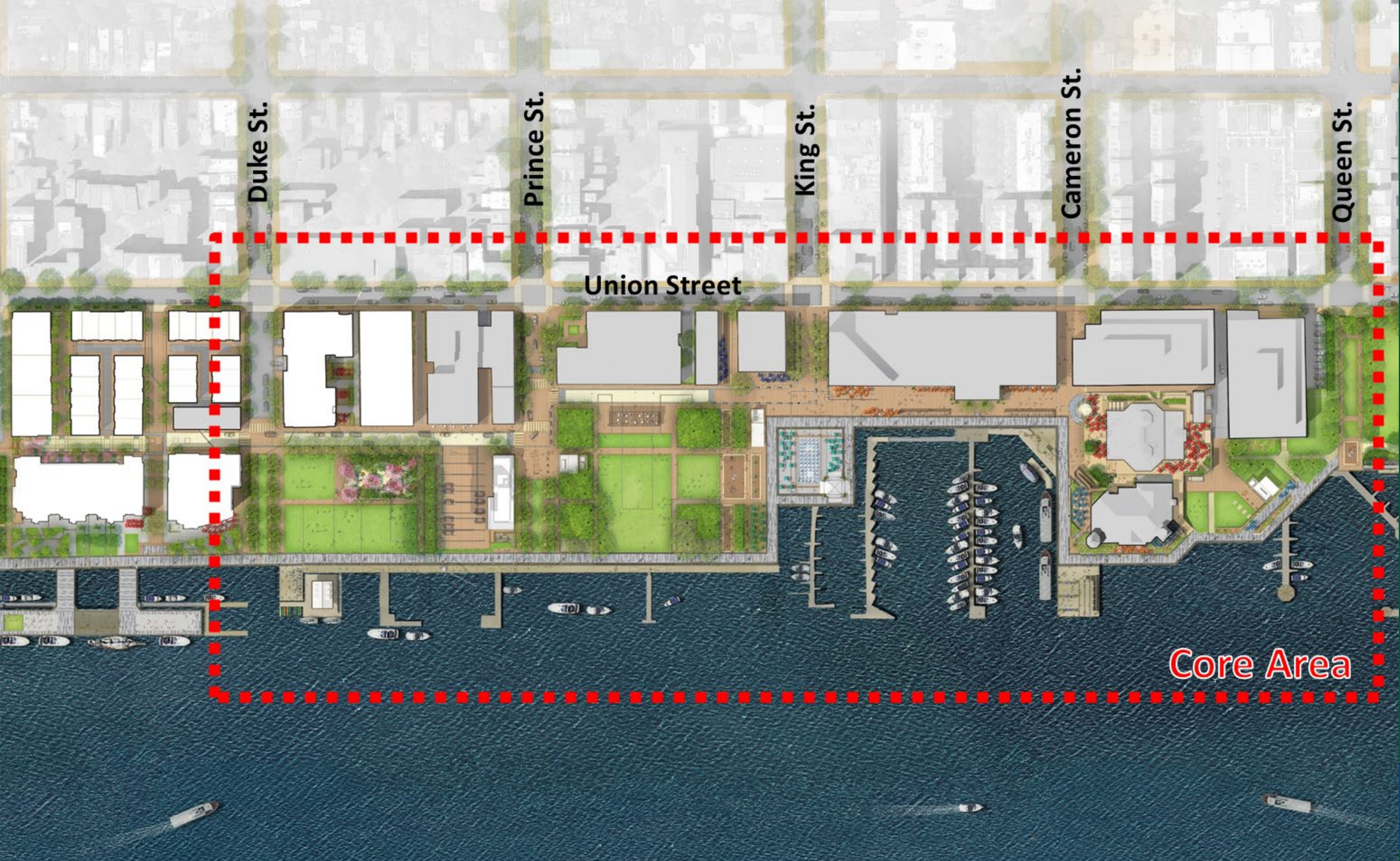

Duke St.

Prince St.

King St.

Cameron St.

Queen St.

Union Street

Core Area

// Baseline Project

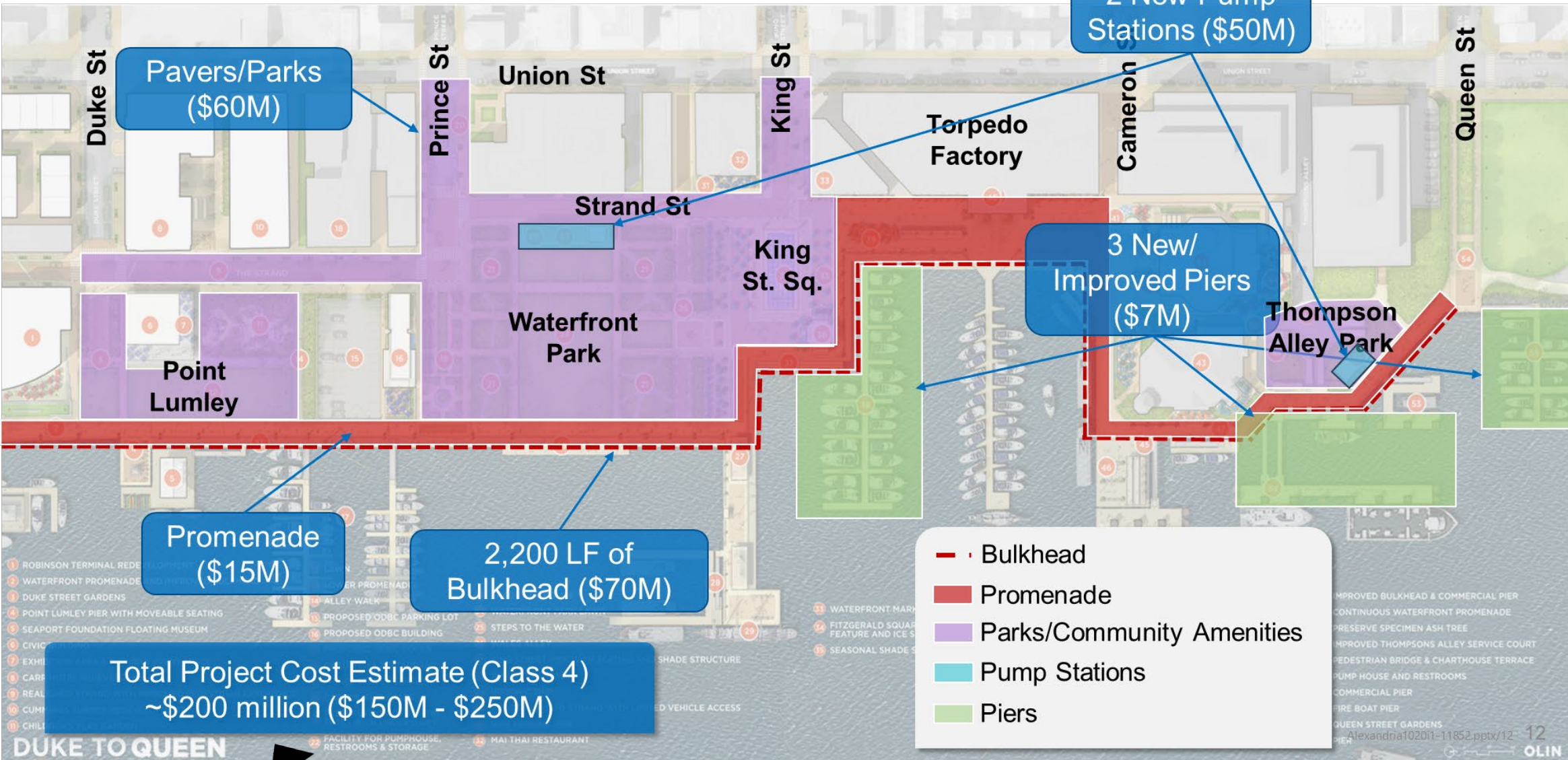

Current Funding in CIP
\$102M

Limitations of the Baseline Project

- Concepts developed a decade ago and rely 100% on “grey” infrastructure
- Best practices in resiliency have changed
 - View water as an asset rather than a liability
 - Concentrate on recovering quickly from (rather than preventing) extreme conditions/events
- Climate change impacts better defined
 - Storm intensity, frequency, and precipitation volume are increasing.
 - Models predict 1-2 feet of sea level rise in the Chesapeake Bay by 2050.¹
- Approach is costly and exceeds current City funding



¹ Chesapeake Stormwater Network, *Review of Recent Research on Climate Projections for the Chesapeake Bay Watershed*, October 20, 2020.

Flood Mitigation – Opportunity to consider

- Changing realities of storm intensity and frequency
- Dynamic regulatory environment
 - Approach to permitting
 - Approach to mitigation and related cost-escalation
- Many communities re-evaluating their approach to shoreline management and flood mitigation
- Consider philosophy of flood resilience





Flood Resilience

- New way of thinking about flood disaster mitigation.
- Embracing the philosophy that we should learn to live with floods and to manage flood risk and not seek to avoid it.
- Resilient flood risk strategies aim at reducing flood risk through:
 - Protection
 - Prevention
 - Preparedness / Quick Recovery

Phasing Plan and Budget adopted by Council (2015)

Phase 1

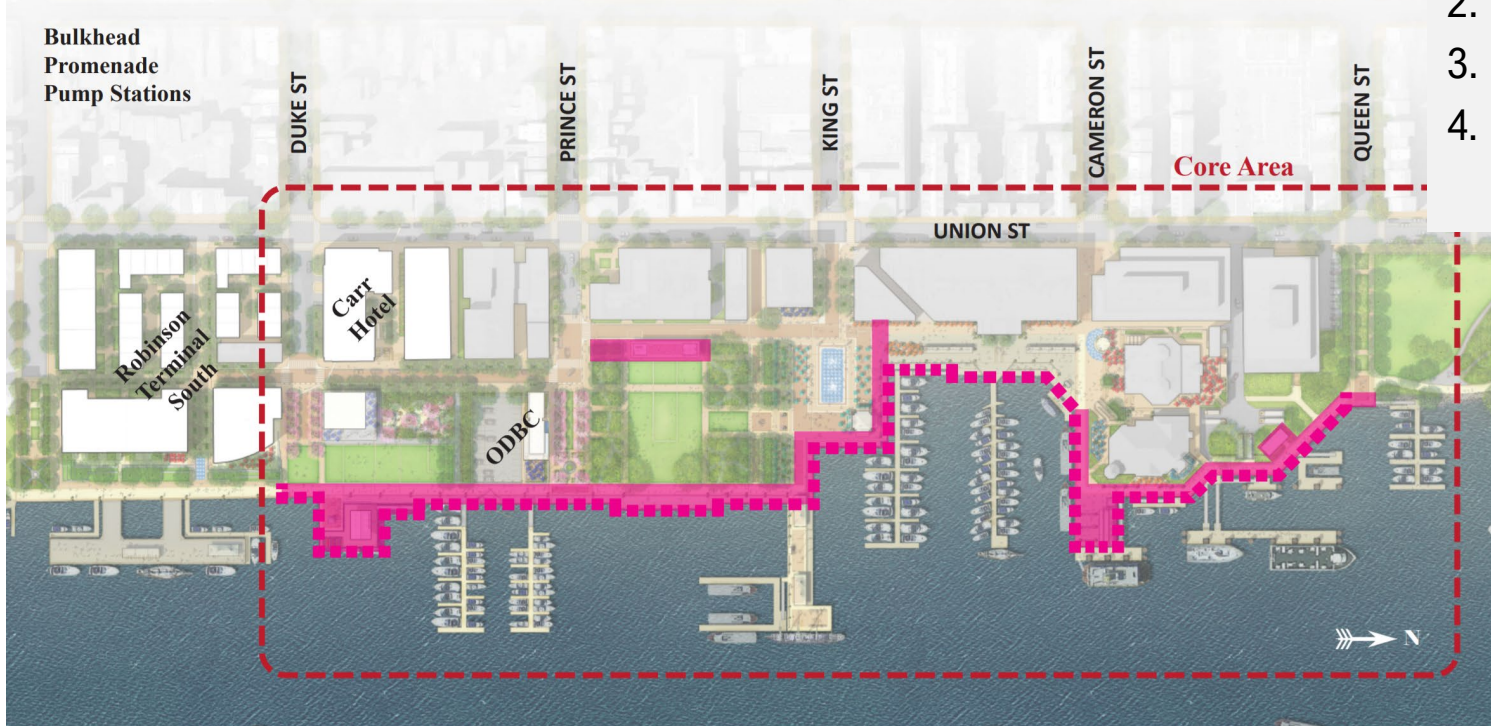

Reflects community priorities:

1. Flood mitigation
2. Riverfront promenade
3. Plaza at the foot of King Street
4. Park improvements

Option A Flood Mitigation & Promenade Priority

Recommended approach for optimizing the Baseline Project included three parallel tracks.

PROJECT PHASING



Could the Baseline Project be implemented over a longer time-period, and restrict the first phase to <\$102M?

VALUE ENGINEERING

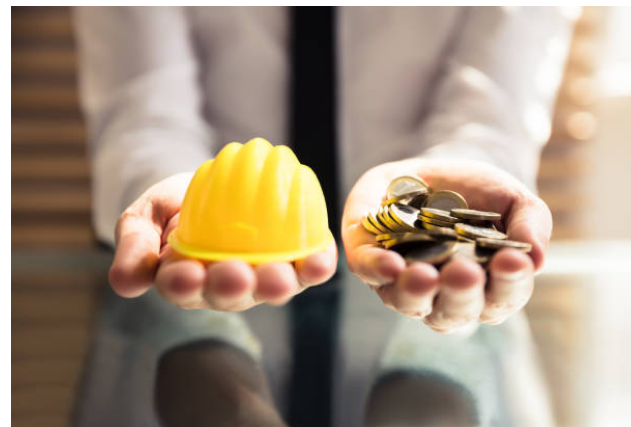

How might we value engineer the “big ticket” items (bulkhead, pump stations, and parks)?

ALTERNATIVE/ GREEN SOLUTIONS



How might green infrastructure offset the need for a new bulkhead and pump stations?

Innovative and Green Solutions

- Integrate **Water** into the **Waterfront**: Rainwater Pavilion & Cloudburst Park



**Long-term
resilience**

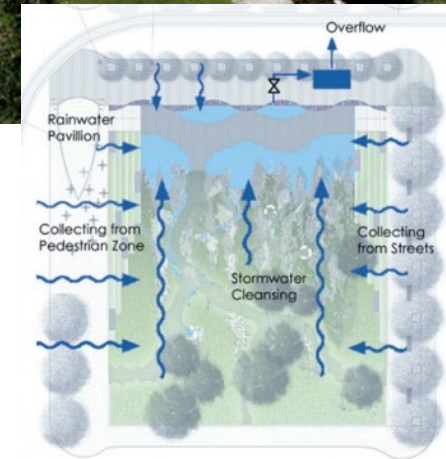

**Flood management while
improving quality of life**

Stormwater Management – Underground Storage

Maximum storage volume of the ADS Storm-Tech DC 780 Chambers. Volume includes stone storage that is required above and below chamber with an assumed 40% porosity.



Waterfront Park

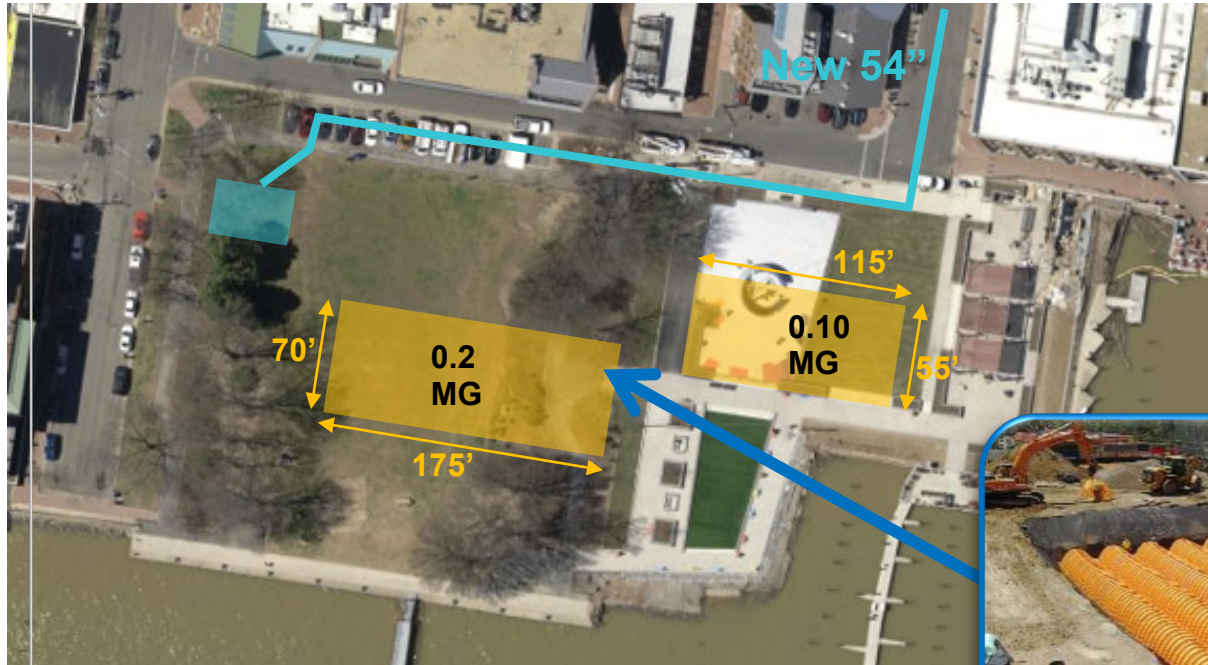

Founders Park

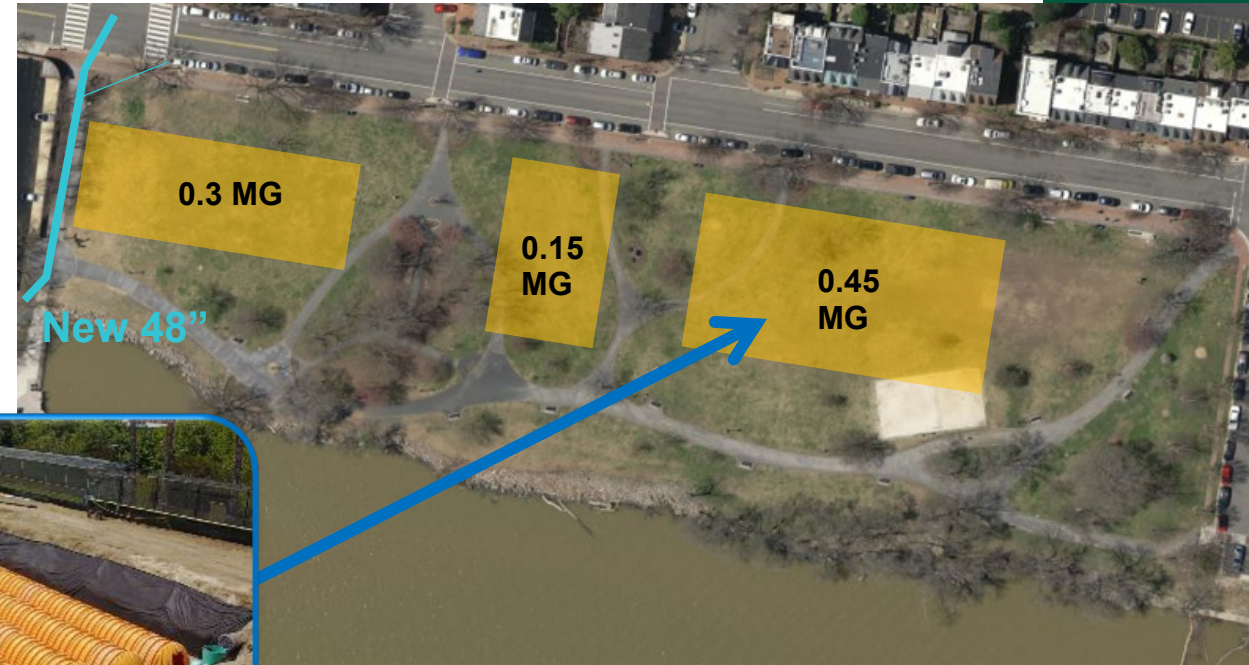

Underground Storage at Waterfront Park can achieve 0.3 MG of stormwater storage

Underground Storage at Founders Park can achieve 0.9 MG of stormwater storage

Stormwater Management – Underground Storage

Maximum storage volume of the ADS Storm-Tech DC 780 Chambers. Volume includes stone storage that is required above and below chamber with an assumed 40% porosity.

Waterfront Park

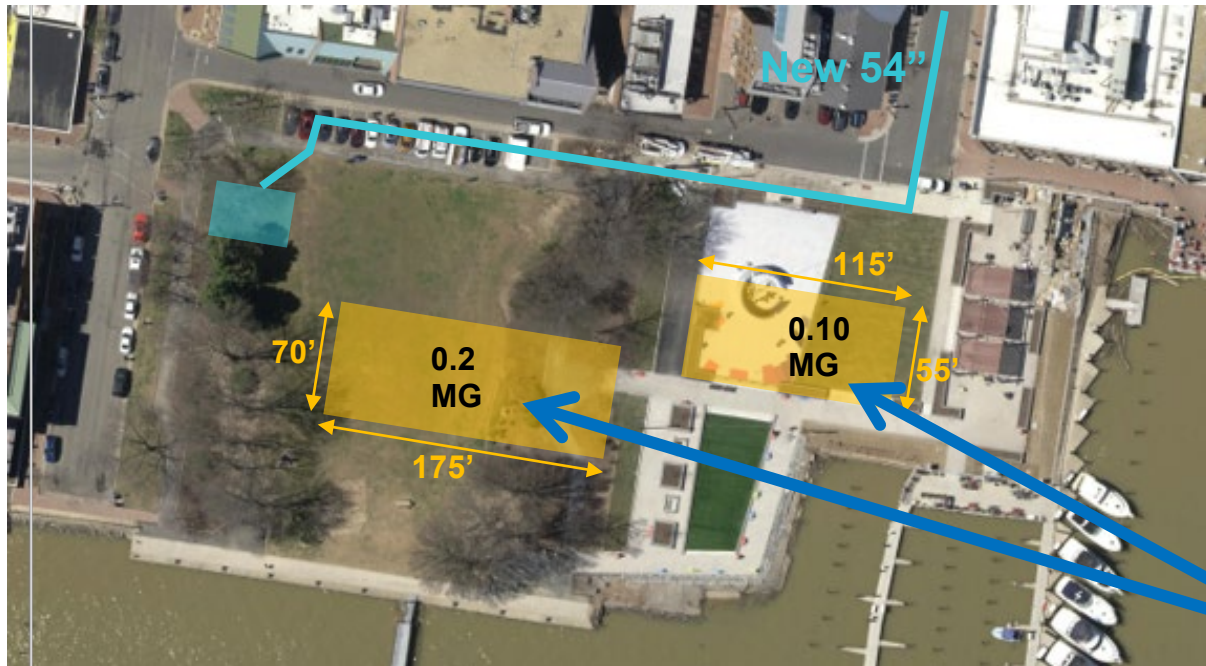

Underground Storage at Waterfront Park can achieve 0.3 MG of stormwater storage

- Reduces pump sizes at Southern Pump Station
- Underground Storage at Founders Park can achieve 0.3 MG of stormwater storage
- No change anticipated to existing site programming



Stormwater Management – Underground Storage



Embrace the Water!

Intercept, Retain, and Drain

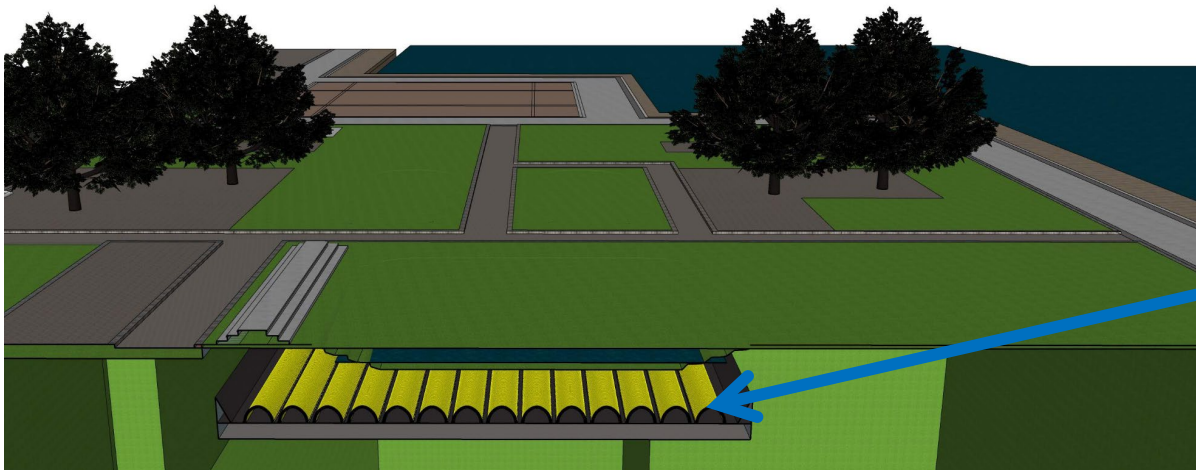
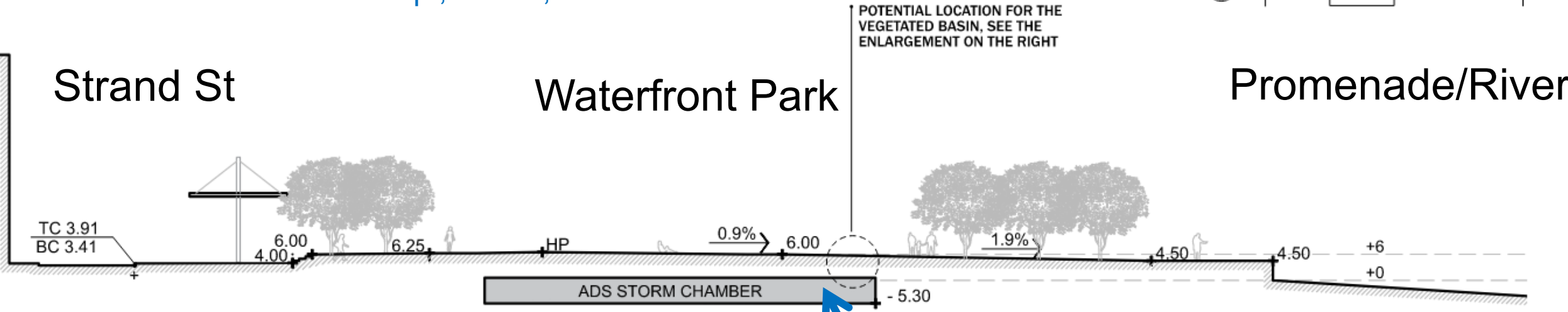

Stormwater Management – Underground Storage

Maximum storage volume of the ADS Storm-Tech DC 780 Chambers. Volume includes stone storage that is required above and below chamber with an assumed 40% porosity.

- Reduces pump sizes at Northern Pump Station
- Underground Storage at Founders Park can achieve 0.9 MG of stormwater storage
- No change required to existing site programming



ADS Storm-Tech

Founders Park

New 48"

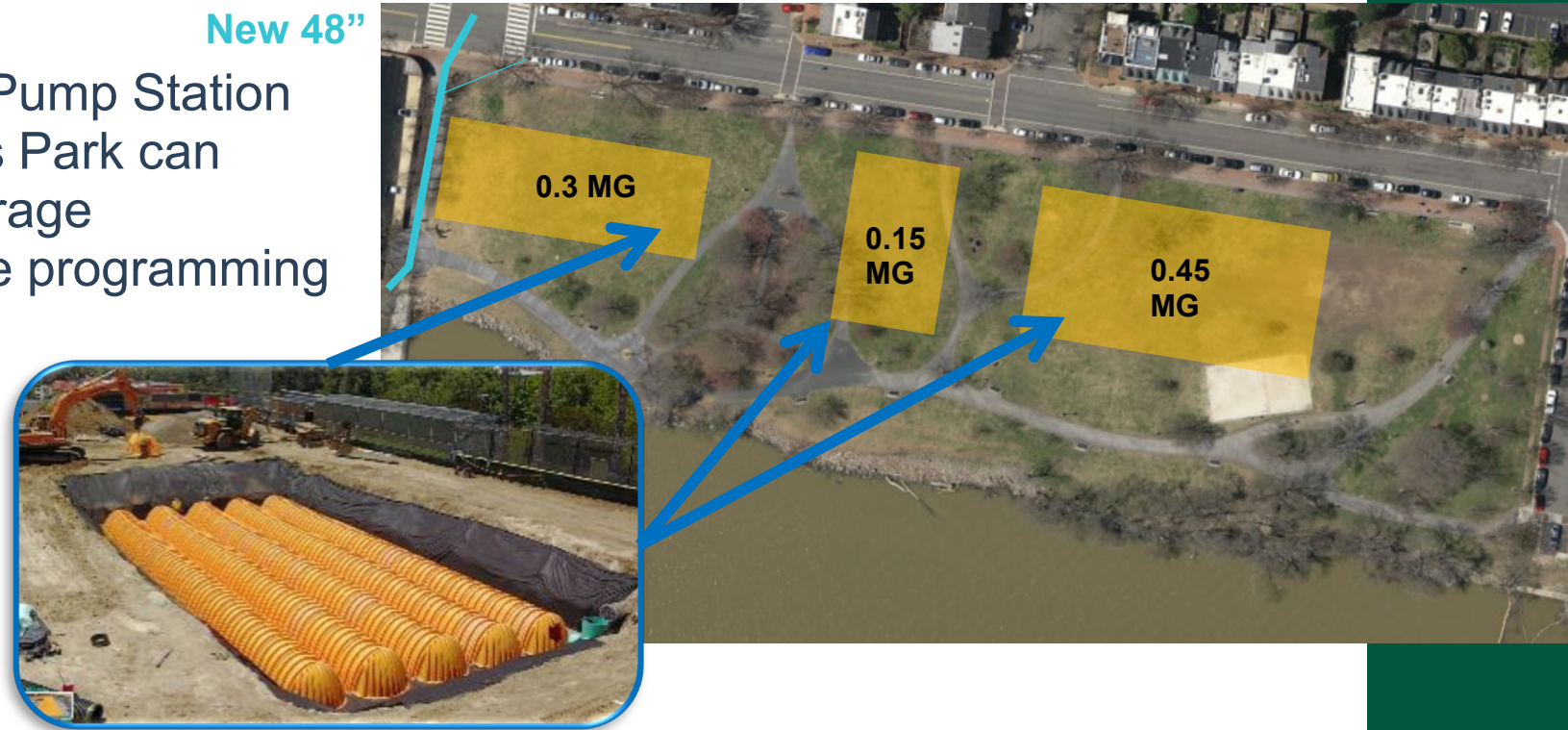

Stormwater Management – Integrate water as amenity

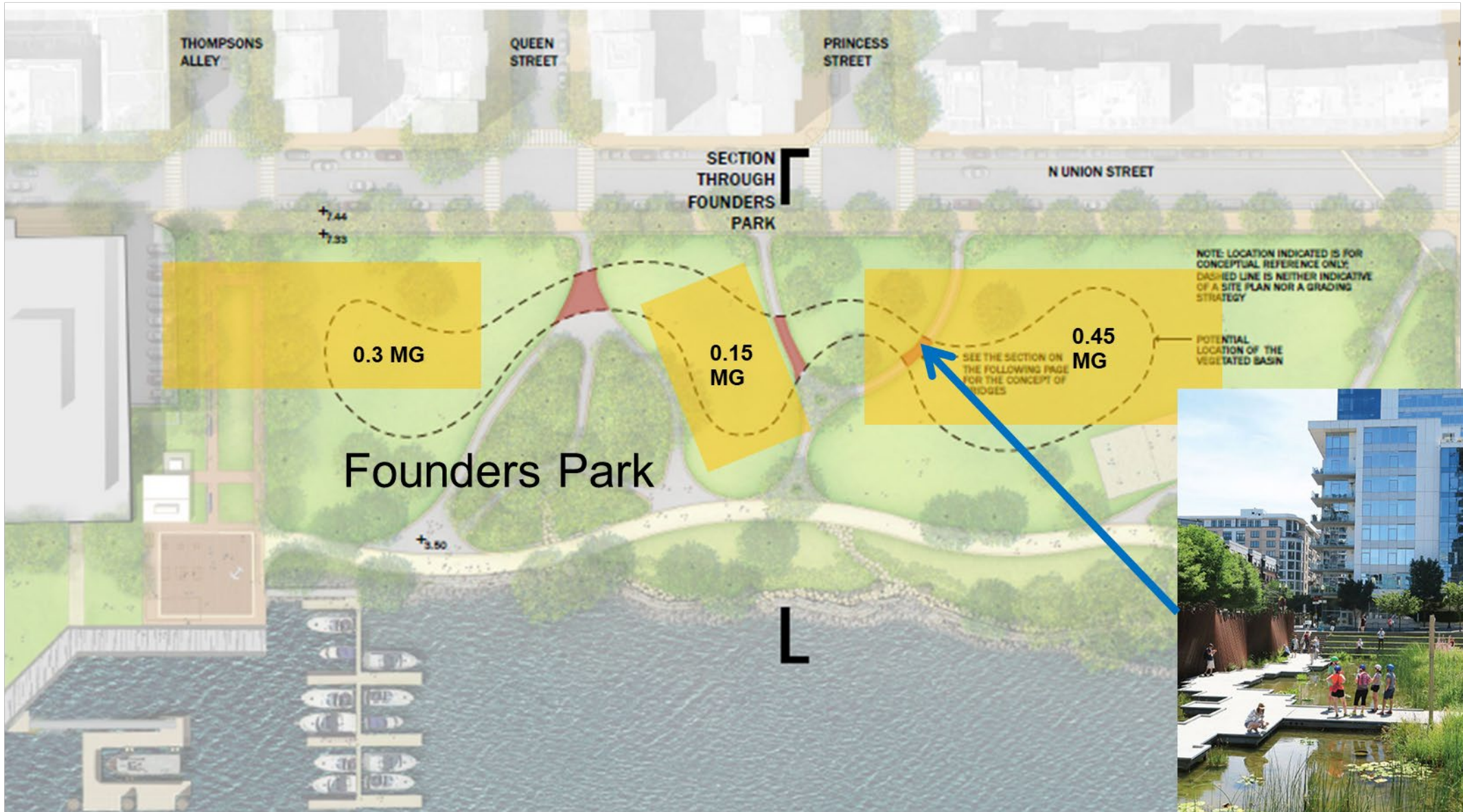

DESIGN VARIANT - STORMWATER PARK INFRASTRUCTURE REVEALED

Stormwater Management – Integrate water as amenity

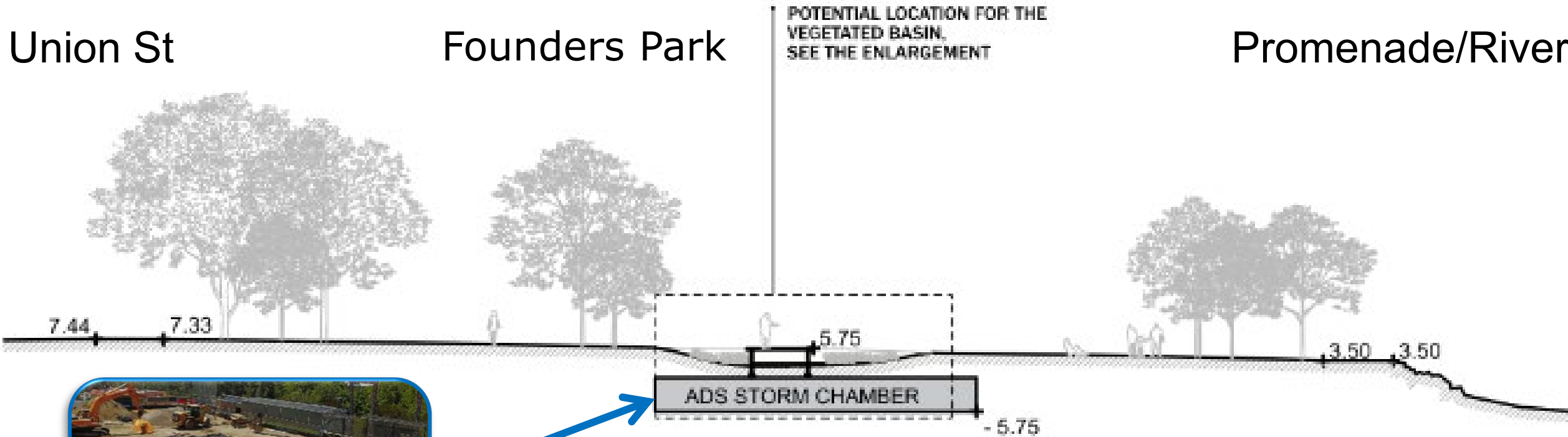

Stormwater Management – Integrate water as amenity

Founders Park

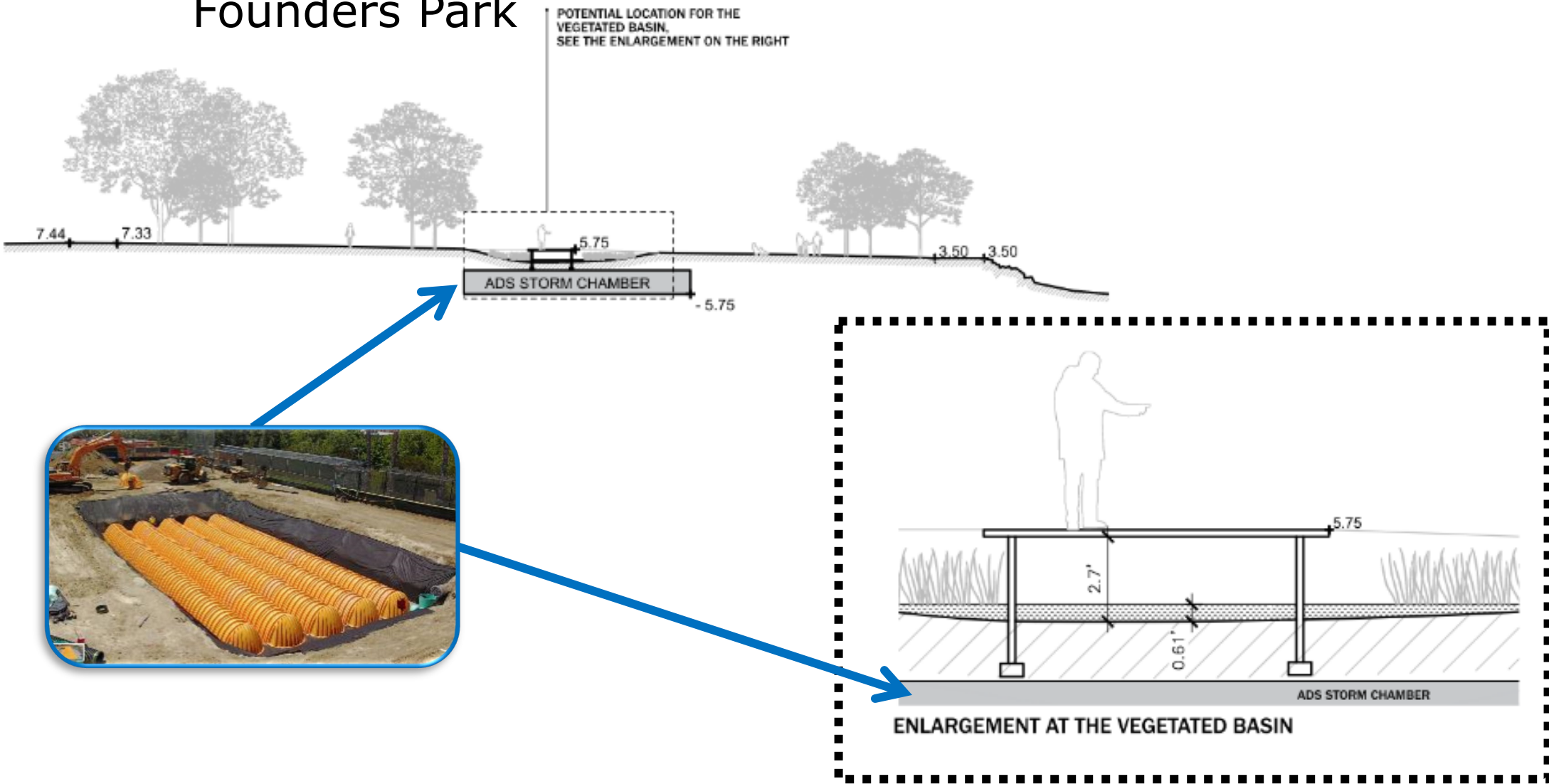

Stormwater Management – Integrate water as amenity



Maximize surface storage

- Reduced turf maintenance
- Reduced open space



Reduced surface storage –

- Reduced turf maintenance
- Maintains more open space

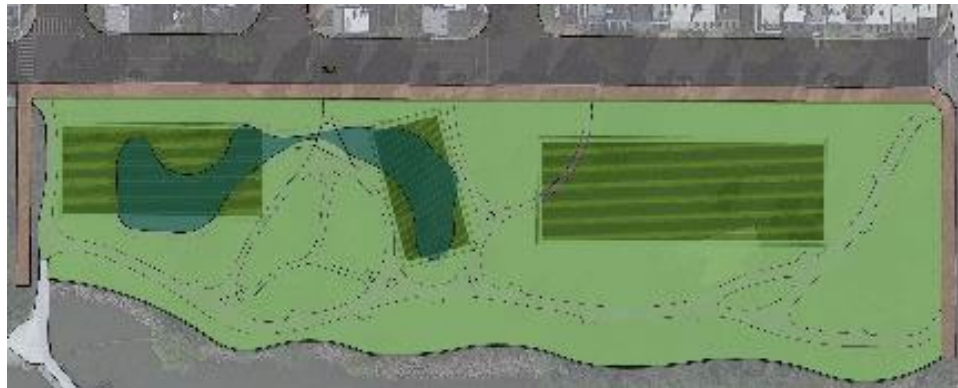

Reduced surface storage –

- Reduced turf maintenance
- Maintains more open space



Stormwater Management – Reduce PS Sizes

- Underground Storage Chambers at Parks

AND

- Stormwater Sewer System Modifications (raised pipes)

= Reduced Pump Station Size

Storm Scenario	Waterfront Park Pump Station #1		Thompsons Alley Pump Station #2	
	Baseline Design	Current Revision	Baseline Design	Current Revision
10-year 2-hour	206 cfs	100 cfs	128 cfs	4 cfs

= Reduced Costs AND greater resiliency for the future

Flood Barriers

New promenade for continuous walking and passive deployment

Flood Barriers

- Bulkhead Repair/Replacement
- Deployable Flood Barriers
- Ha-ha Wall & Grading

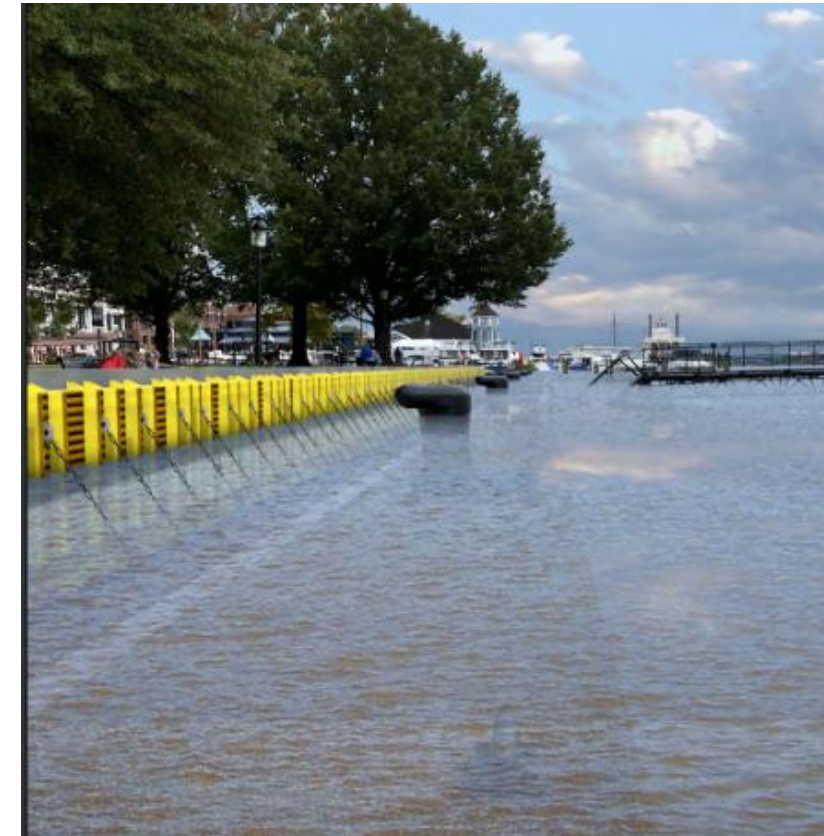

- Hinged barriers (Floodbreak FreeView Flood Barrier)
- Self-deploying Barrier
- Embed in promenade and finish with pavers
- Integrated into landscape as public amenity

// Seawall Barrier

Name	Deployment	Application	Benefits	Issues/Barriers
Seawall Barrier	Passive	Shoreline	<ul style="list-style-type: none"> • Maintain waterfront views 24/7 • Structural support posts can span > 10-ft apart • Material cost is \$4M for entire length of bulkhead 	<ul style="list-style-type: none"> • Does not eliminate the need for pump stations • Regularly clean exposed surfaces including glass



// Flood Gate

Name	Deployment	Application	Benefits	Issues/Barriers
Flood Gate <i>FloodBreak</i> <i>FreeView Flood Barrier</i>	Passive	Shoreline	<ul style="list-style-type: none"> No height or length limitation HS-25, HS-20 and pedestrian rated Embed in promenade and sidewalk Edge-to-edge seal available Adapt to sloped areas 	<ul style="list-style-type: none"> Excavation required for new foundation or tie-in to bulkhead To activate gate: Intake valve requires drilling through bulkhead. Drainpipe with SD connection could double the price.

To install product along the entire bulkhead, material cost is \$5M with a 3.5-ft self-deploying wall.

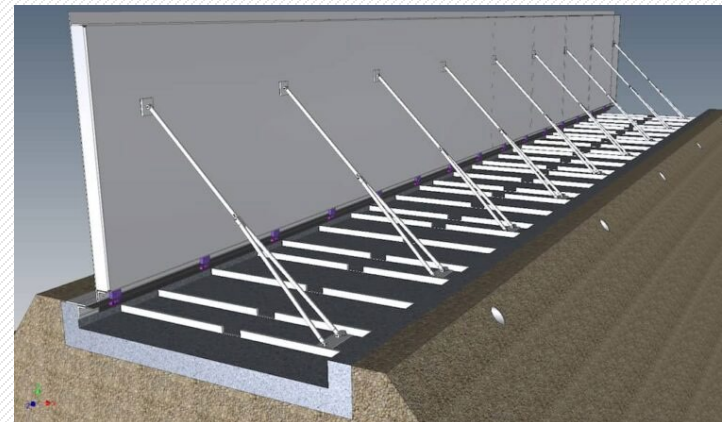

Photos courtesy of FloodBreak
<http://floodbreak.com/products/freeview-flood-barriers/>

// Flood Gate

Name	Deployment	Application	Benefits	Issues/Barriers
Flood Gate <i>FloodBreak Gate</i>	Passive	Building/ Segments	<ul style="list-style-type: none"> • Customized height and length • Invisible when not needed • Customized 18-28" gate depth to work around conflicts • Product cost of each gate is < \$250k 	<ul style="list-style-type: none"> • Tie in needs to be watertight • Soil conditions and flood loads dictate foundation and excavation • Connection to storm drain is required to activate gate



// Flood Barrier

Name	Deployment	Application	Benefits	Issues/Barriers
Flood Barrier <i>Bottom hinged flood barrier</i>	Active or Passive	Building or Shoreline	<ul style="list-style-type: none"> • Invisible when not needed • Rises with flood-waters and is self-closing when high waters recede • Built into permanent flood wall, walkway or building entrance • Hidden storage basin depth is 24" + structural footing 	<ul style="list-style-type: none"> • Requires connection to flood water supply via 4" drainpipe or drilling through bulkhead for intake valve. • Shipping only available up to 50' increments
<p>Opportunity may exist to integrate into existing walkway and promenade behind the bulkhead. Material cost is \$12-14M across entire bulkhead.</p>				



Flood Barriers – Building Floodproofing



Concealed Deployable Options



Deployed condition

Alternative Flood Barriers

Flood Barriers

- Bulkhead Repair/Replacement
- Flood Proof Glass



Flood-proof glass integrated with the handrail and lighting proposed along promenade.



Alternative Flood Barriers

- Floodproof glass (Fenex Glass Flood Wall)
- Integrate with handrails and lighting along promenade
- Flood fence

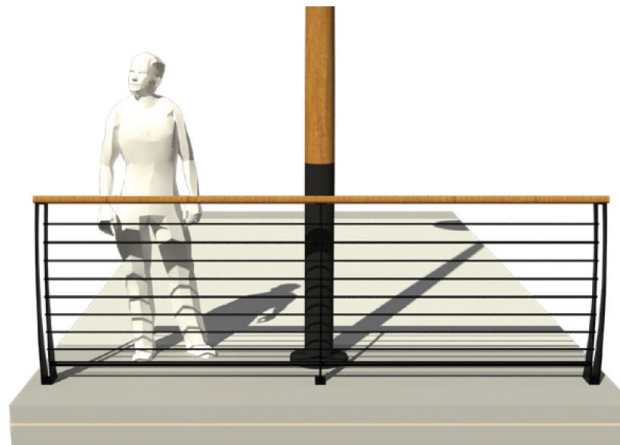
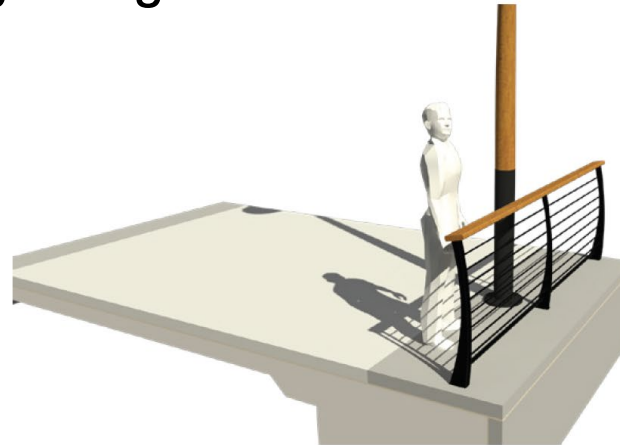

Flood Barriers – Option 1 Inland Flood Protection (Revise King Street Square Shoreline)

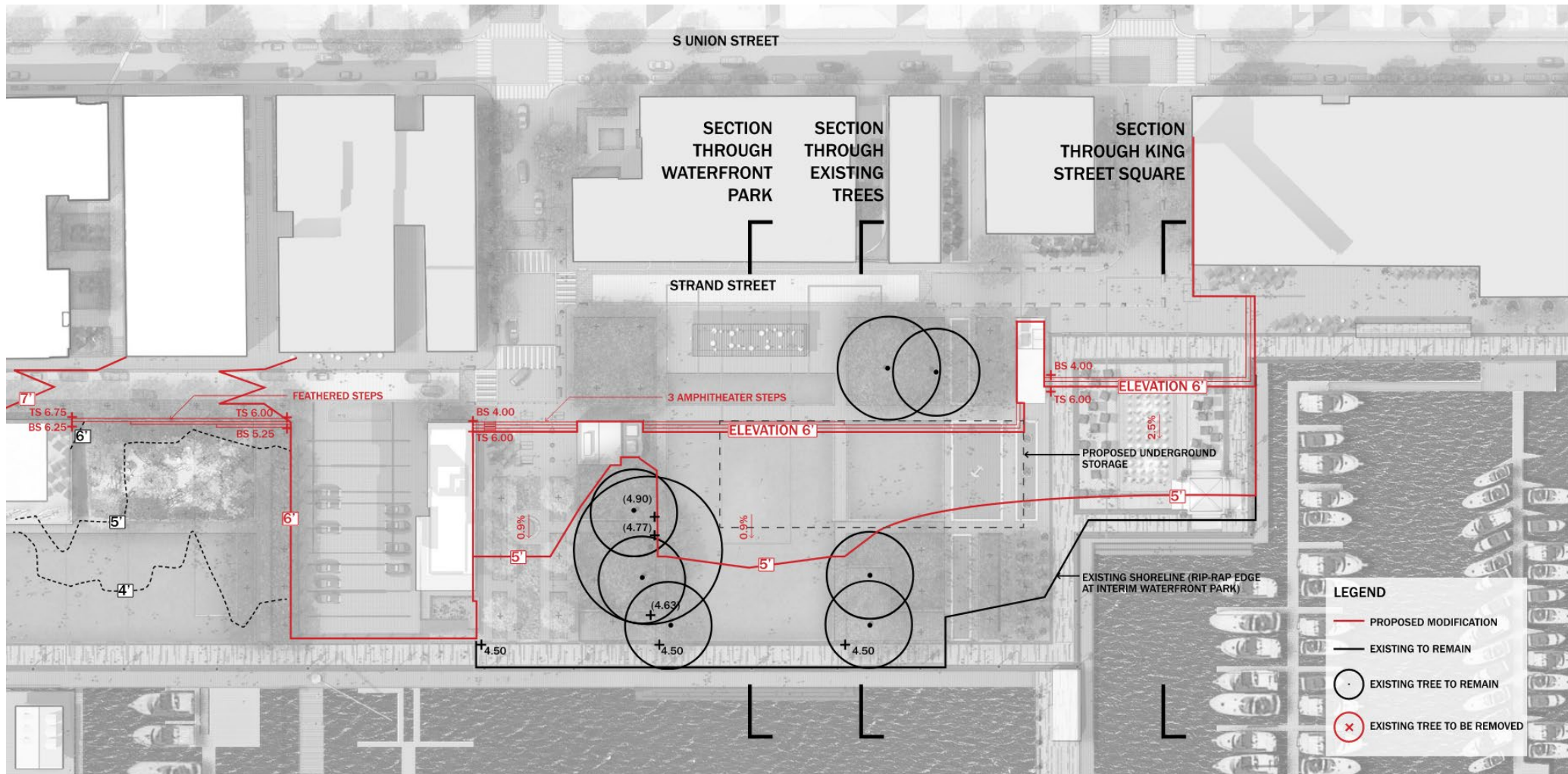

Flood Barriers – Option 1 Inland Flood Protection (Revise King Street Square Shoreline)

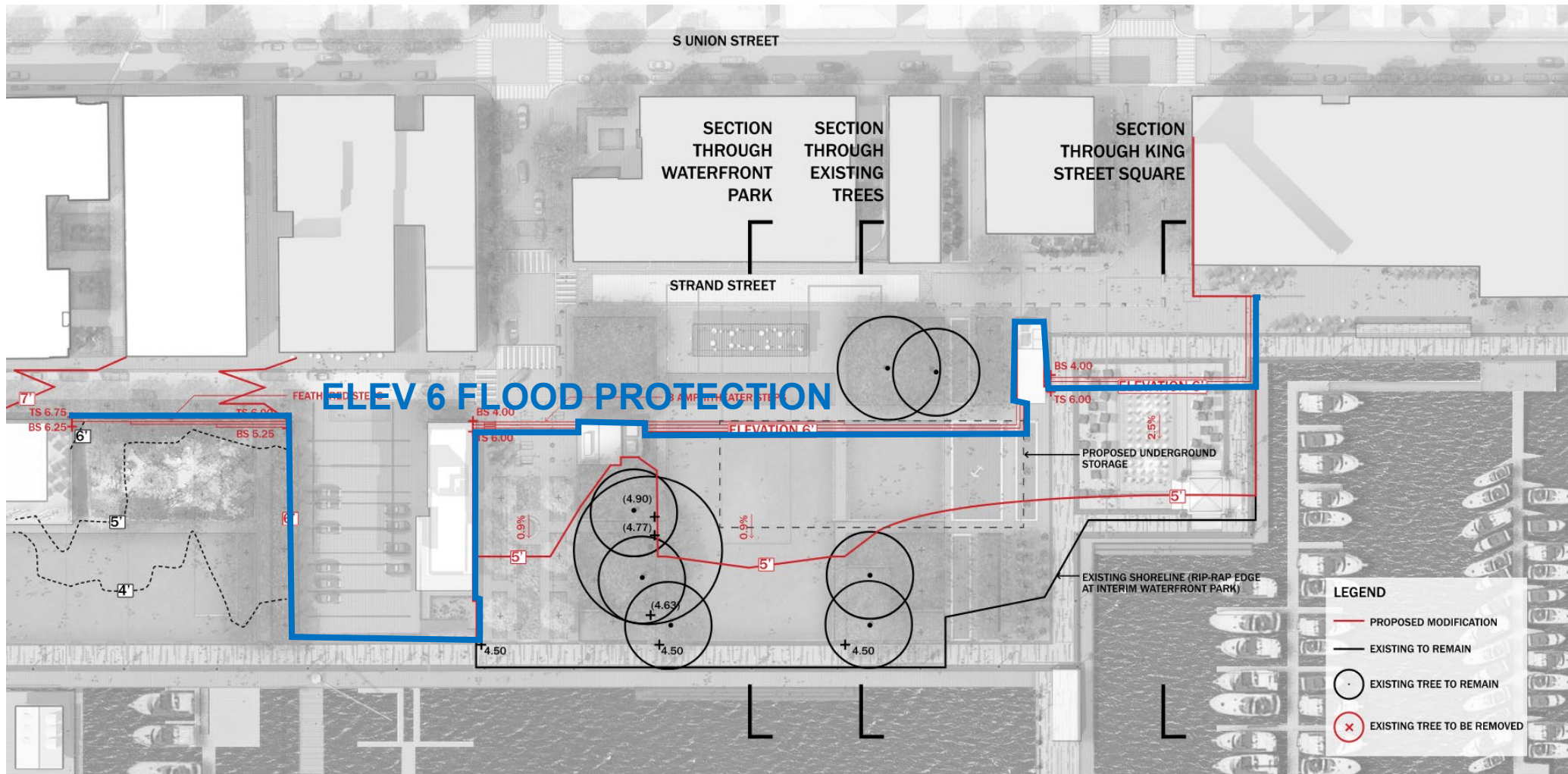

Flood Barriers – Option 1 Inland Flood Protection (Revise King Street Square Shoreline)

SECTION THROUGH WATERFRONT PARK

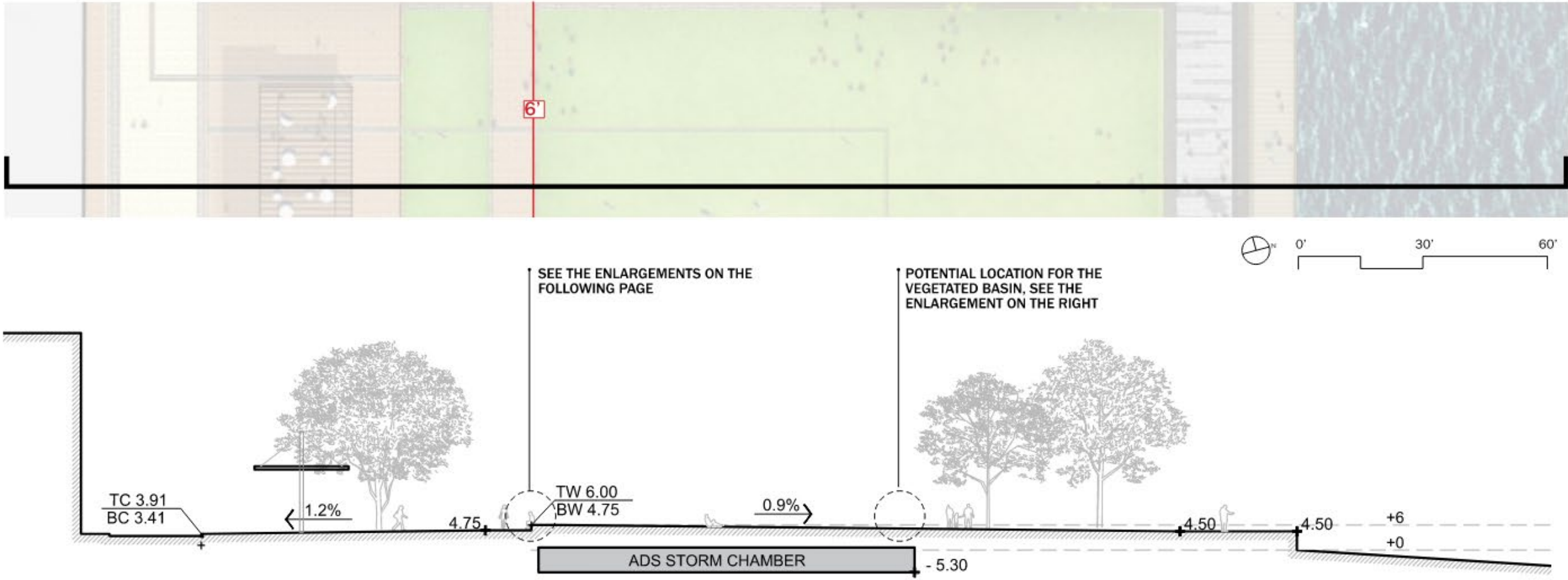

Flood Barriers – Option 1 Inland Flood Protection (Revise King Street Square Shoreline)

SECTION THROUGH WATERFRONT PARK

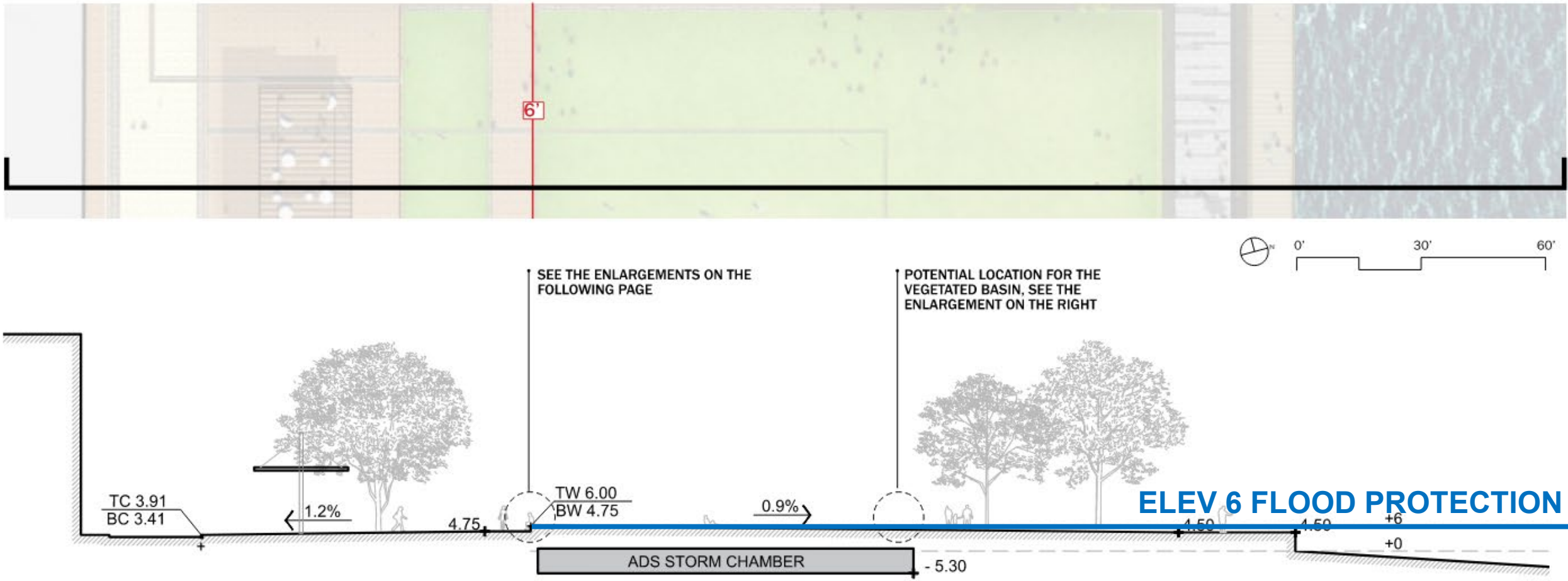

Flood Barriers – Option 1 Inland Flood Protection (Revise King Street Square Shoreline)

SECTION THROUGH KING STREET SQUARE

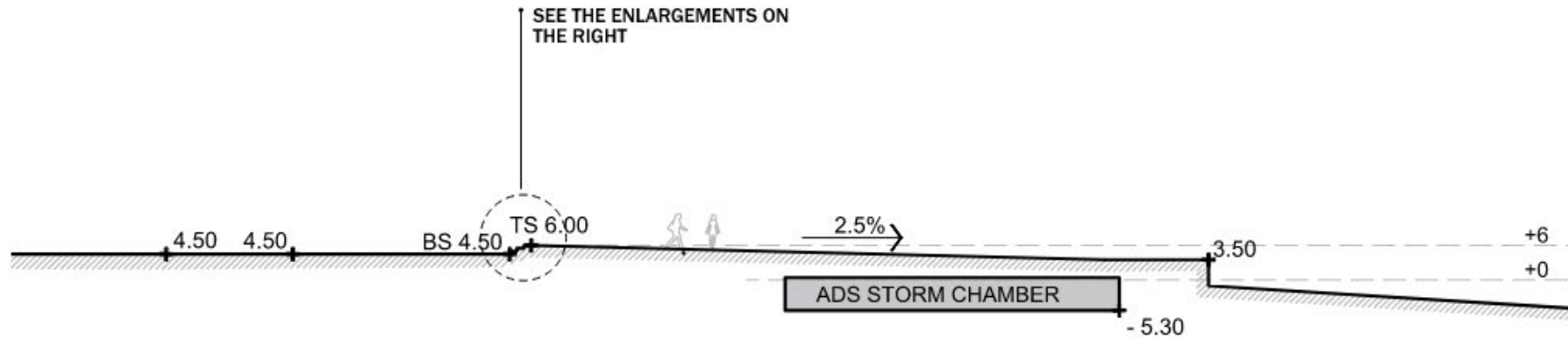

Flood Barriers – Option 1 Inland Flood Protection (Revise King Street Square Shoreline)

SECTION THROUGH KING STREET SQUARE

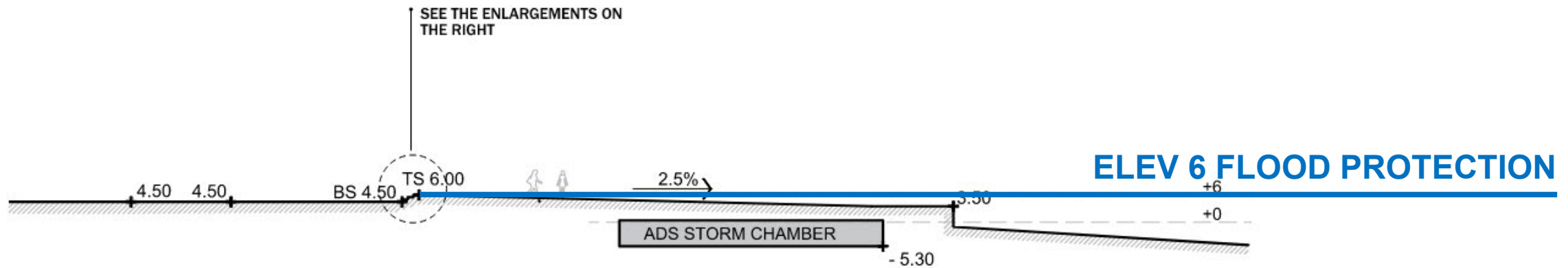

Flood Barriers – Option 1 Inland Flood Protection (Revise King Street Square Shoreline)

ENLARGEMENT AT THE SEAT WALL

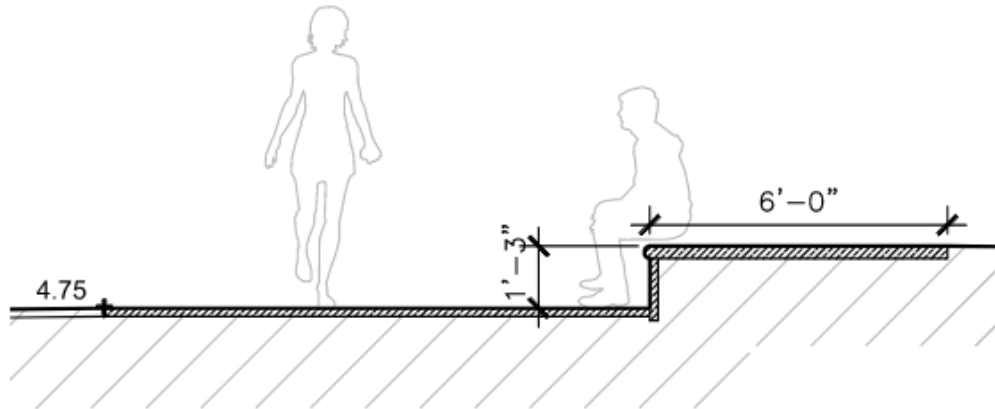

VARIATION 1-A | AMPHITHEATER STEPS

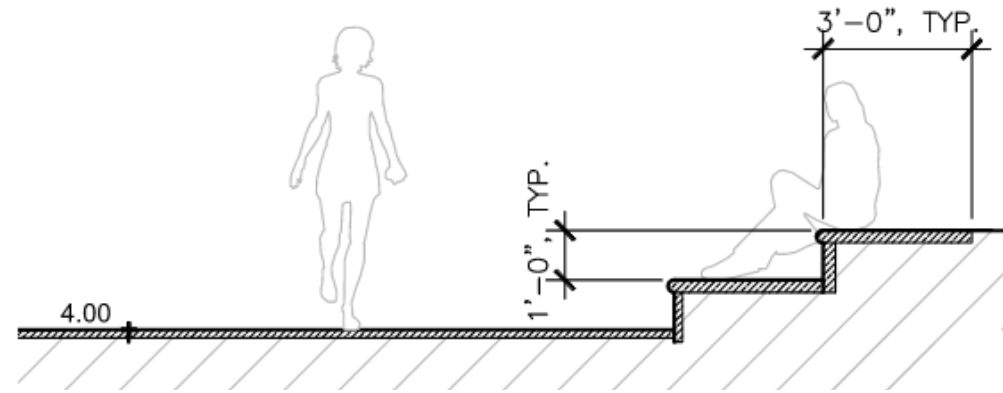

VARIATION 1-B | AMPHITHEATER STEPS WITH ADDITIONAL FLOOD PROTECTION

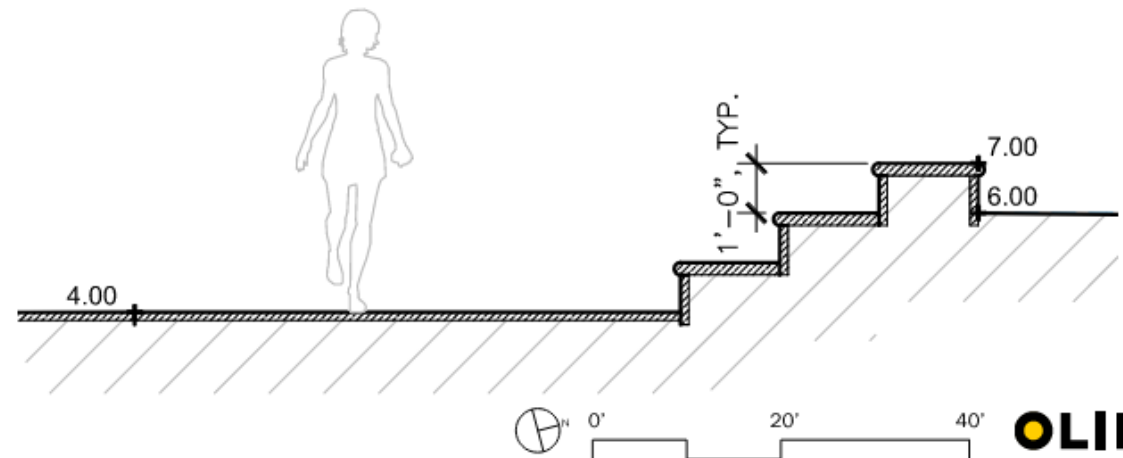

Flood Barriers – Option 2 Inland Flood Protection (Retain King Street Square Shoreline)

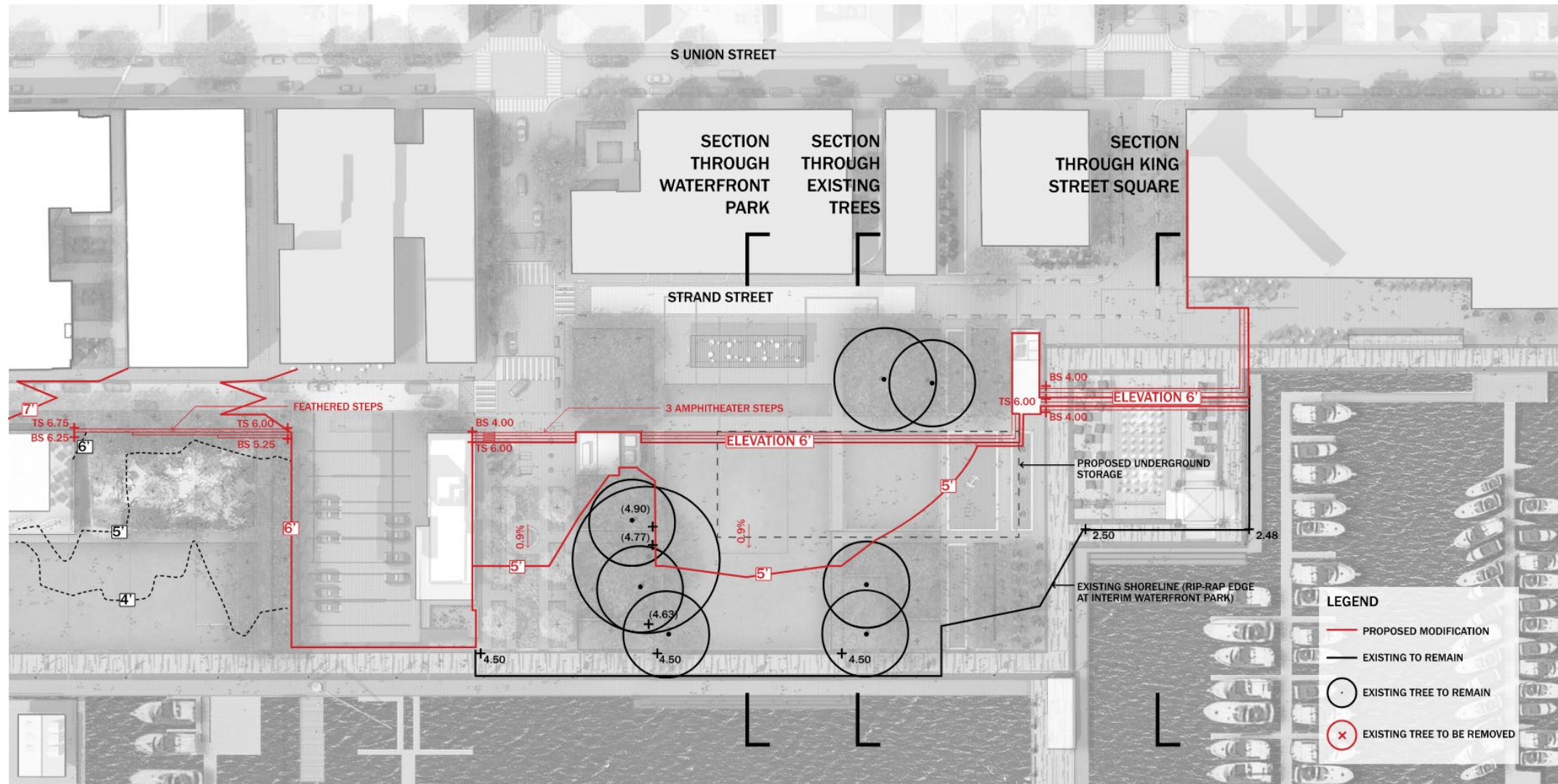

Flood Barriers – Option 3 Flood Protection at Promenade (OLIN PREFERRED)

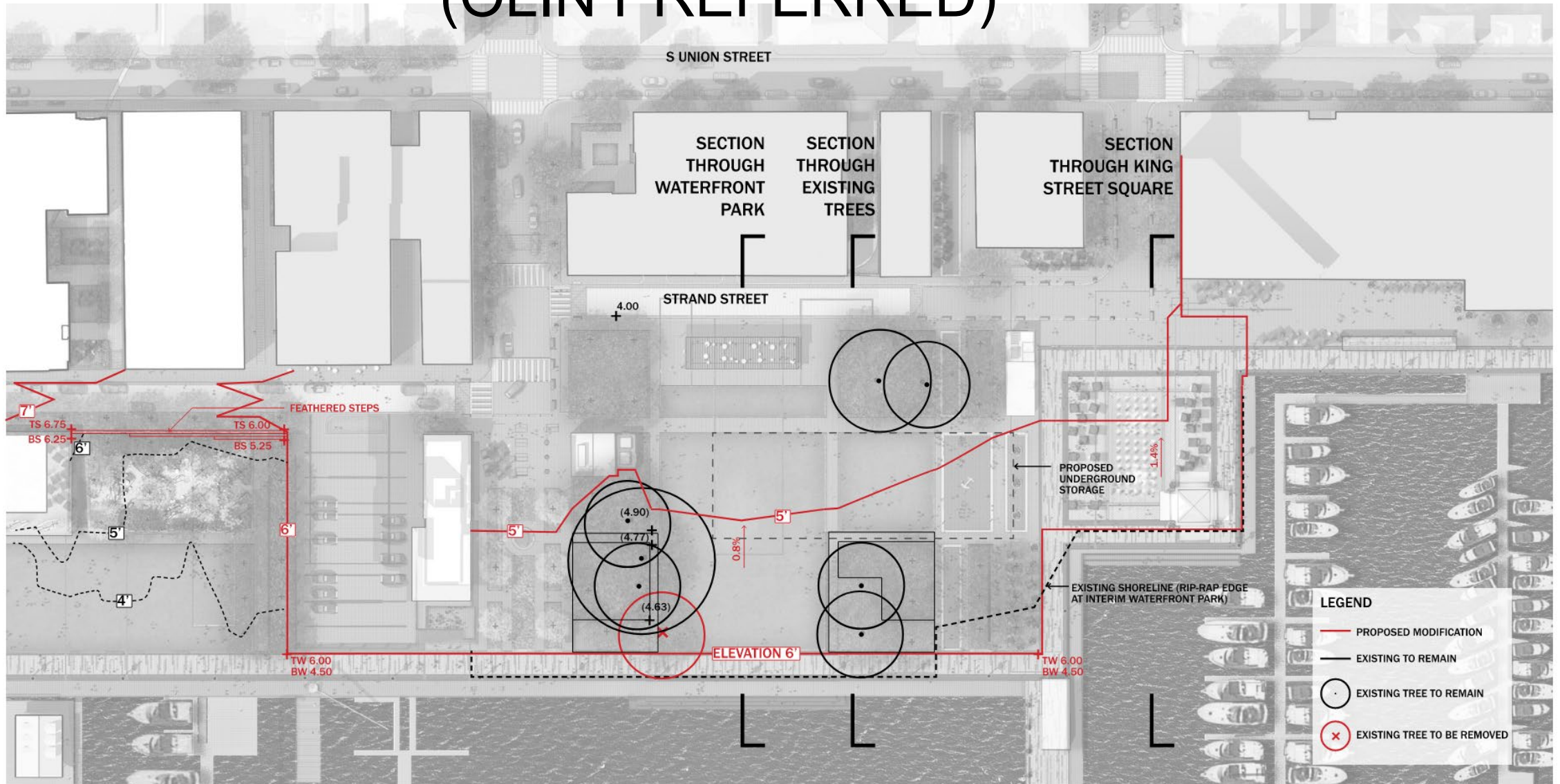

LEGEND

- PROPOSED MODIFICATION
- EXISTING TO REMAIN
- EXISTING TREE TO REMAIN
- ⊗ EXISTING TREE TO BE REMOVED



Flood Barriers – Option 3 Flood Protection at Promenade (OLIN PREFERRED)

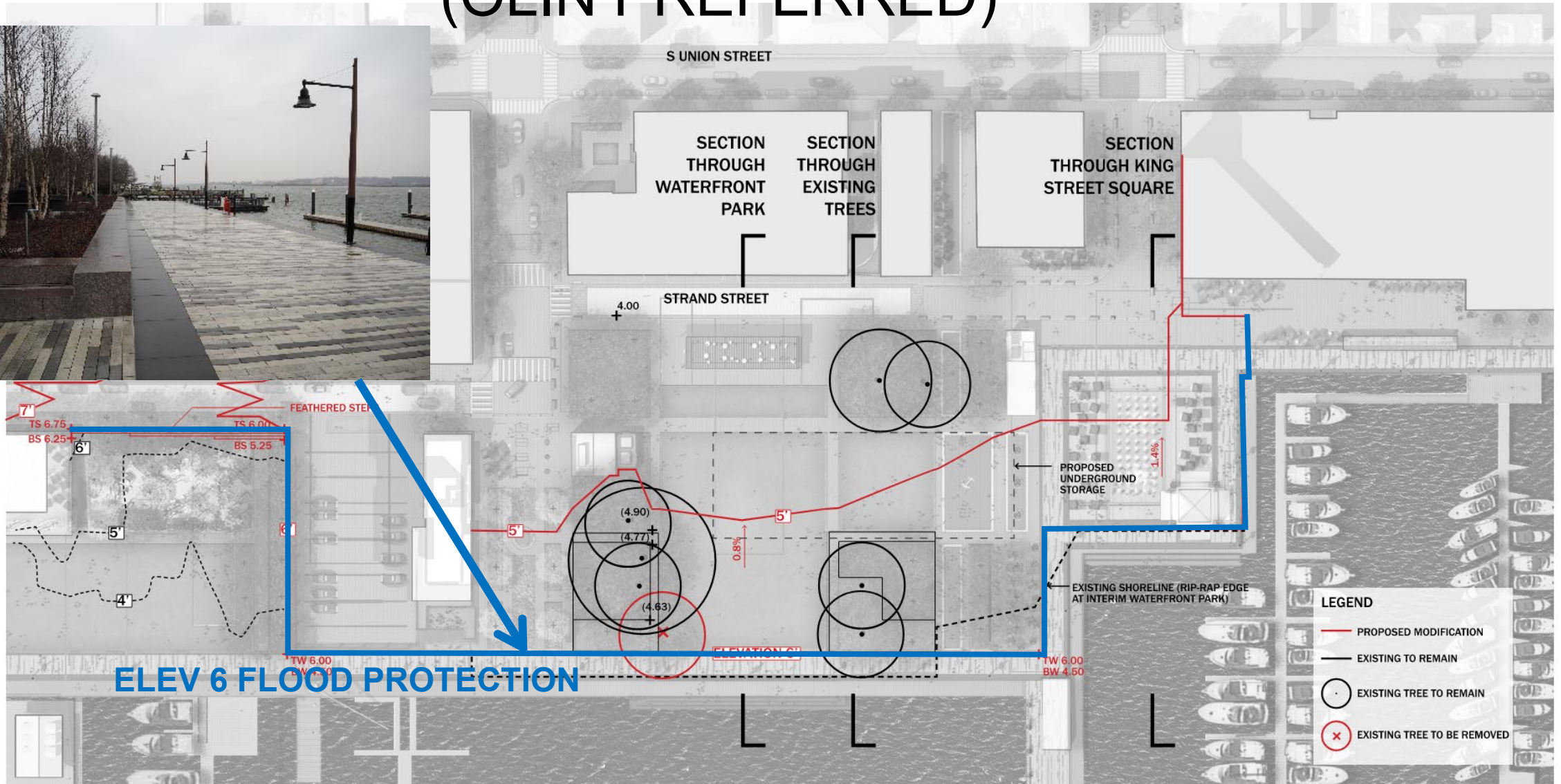

Flood Barriers – Option 3 Flood Protection at Promenade

SECTION THROUGH WATERFRONT PARK

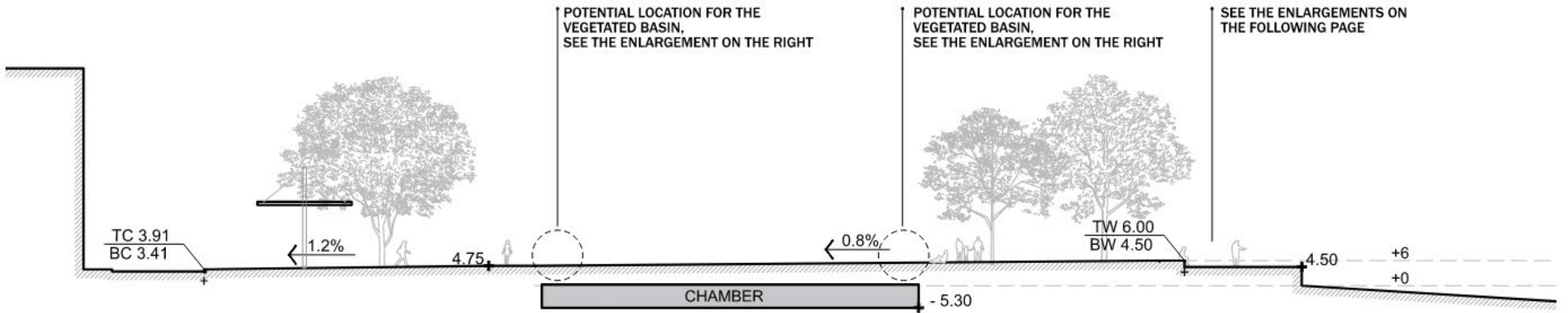
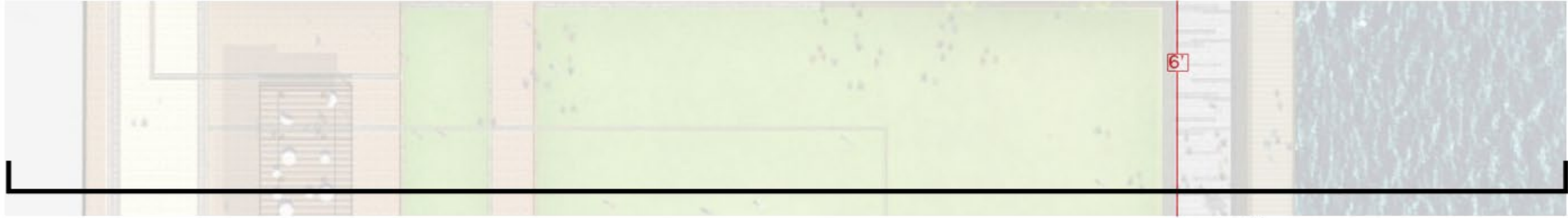

Flood Barriers – Option 3 Flood Protection at Promenade

SECTION THROUGH WATERFRONT PARK

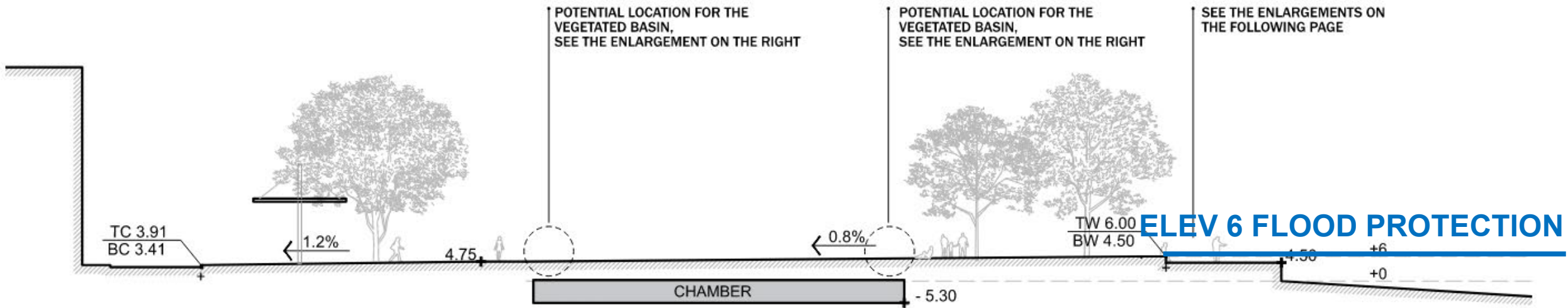
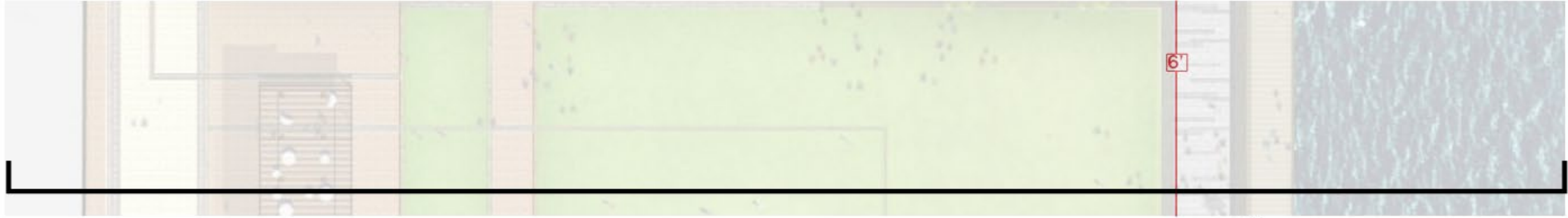

Flood Barriers – Option 3 Flood Protection at Promenade

SECTION THROUGH KING STREET SQUARE

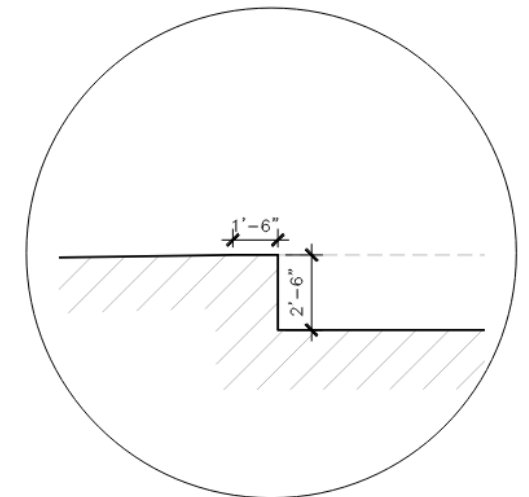
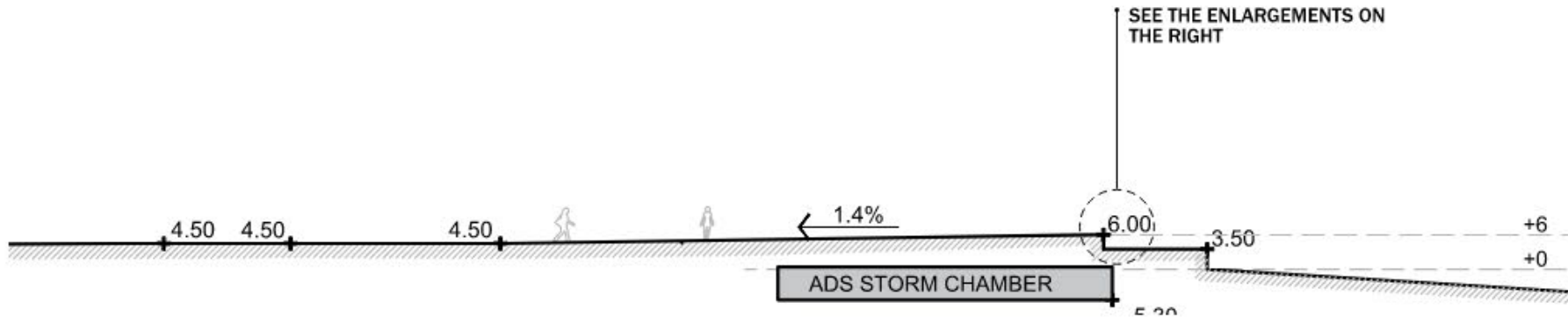

ENLARGEMENT AT KING STREET SQUARE

Flood Barriers – Option 3 Flood Protection at Promenade (OLIN PREFERRED)

ENLARGEMENT AT THE SEAT WALL

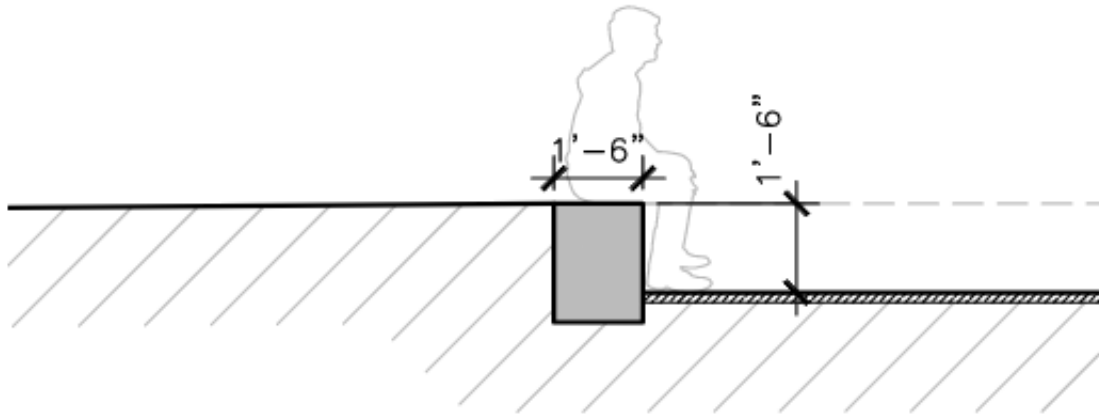

VARIATION 3-A | STEPS

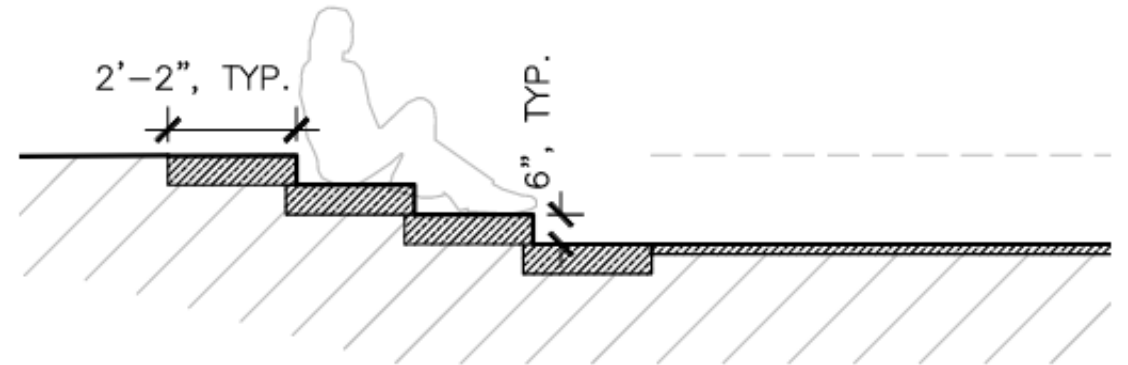

Flood Barriers – Option 5 Inland Flood Protection (Deployable at King Street Square)

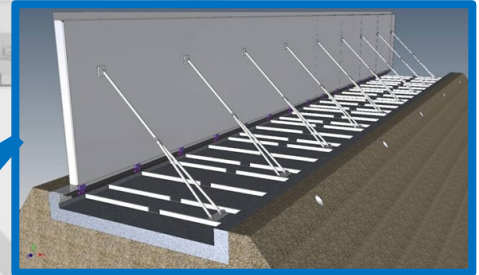
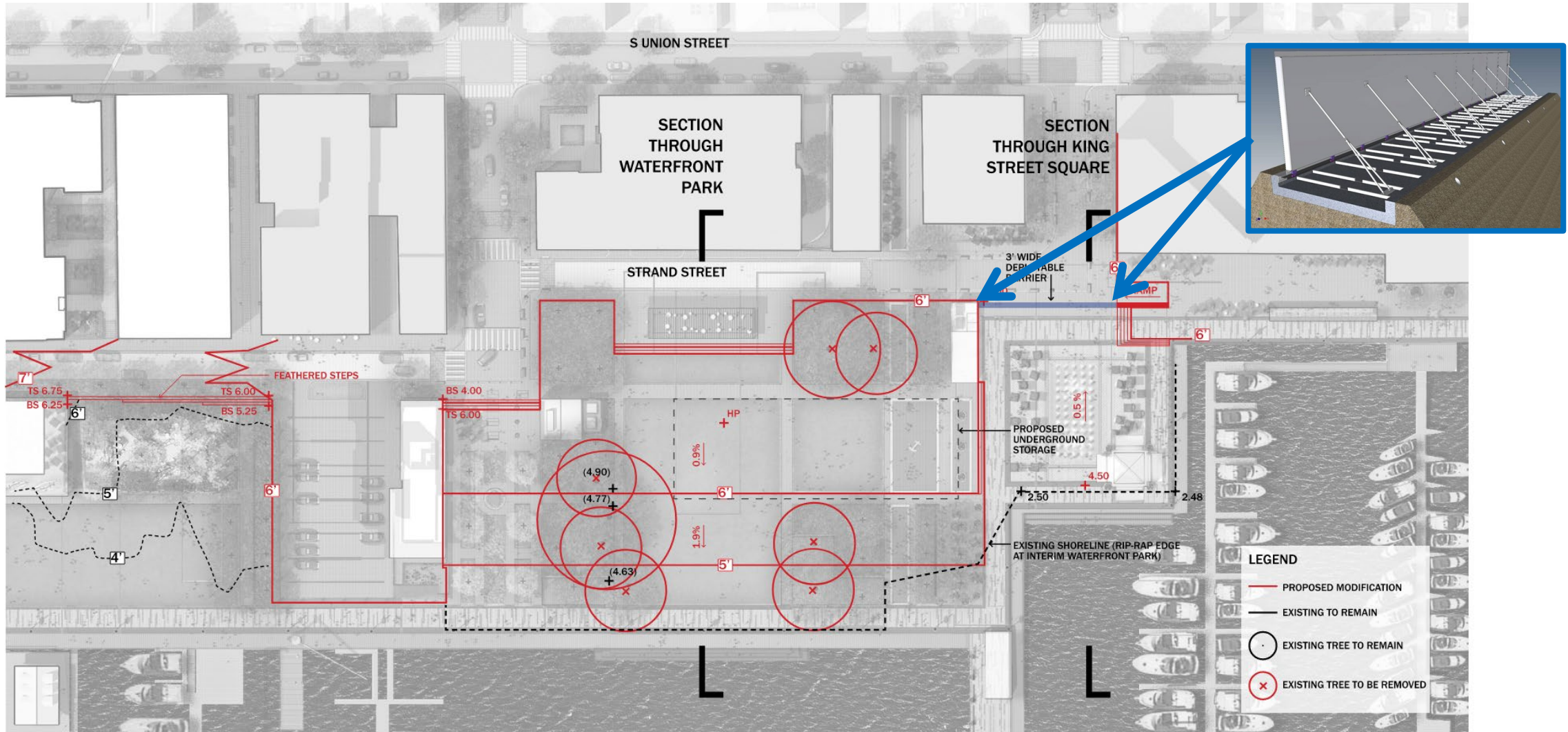

- LEGEND**
- PROPOSED MODIFICATION
 - EXISTING TO REMAIN
 - EXISTING TREE TO REMAIN
 - ⊗ EXISTING TREE TO BE REMOVED

Flood Barriers – Option 5 Inland Flood Protection (Deployable at King Street Square)

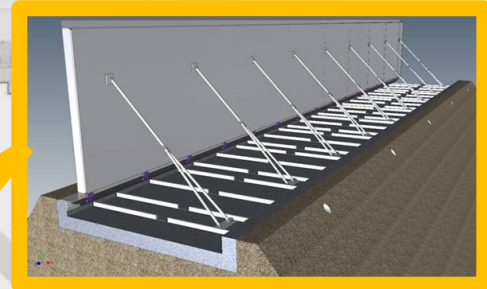
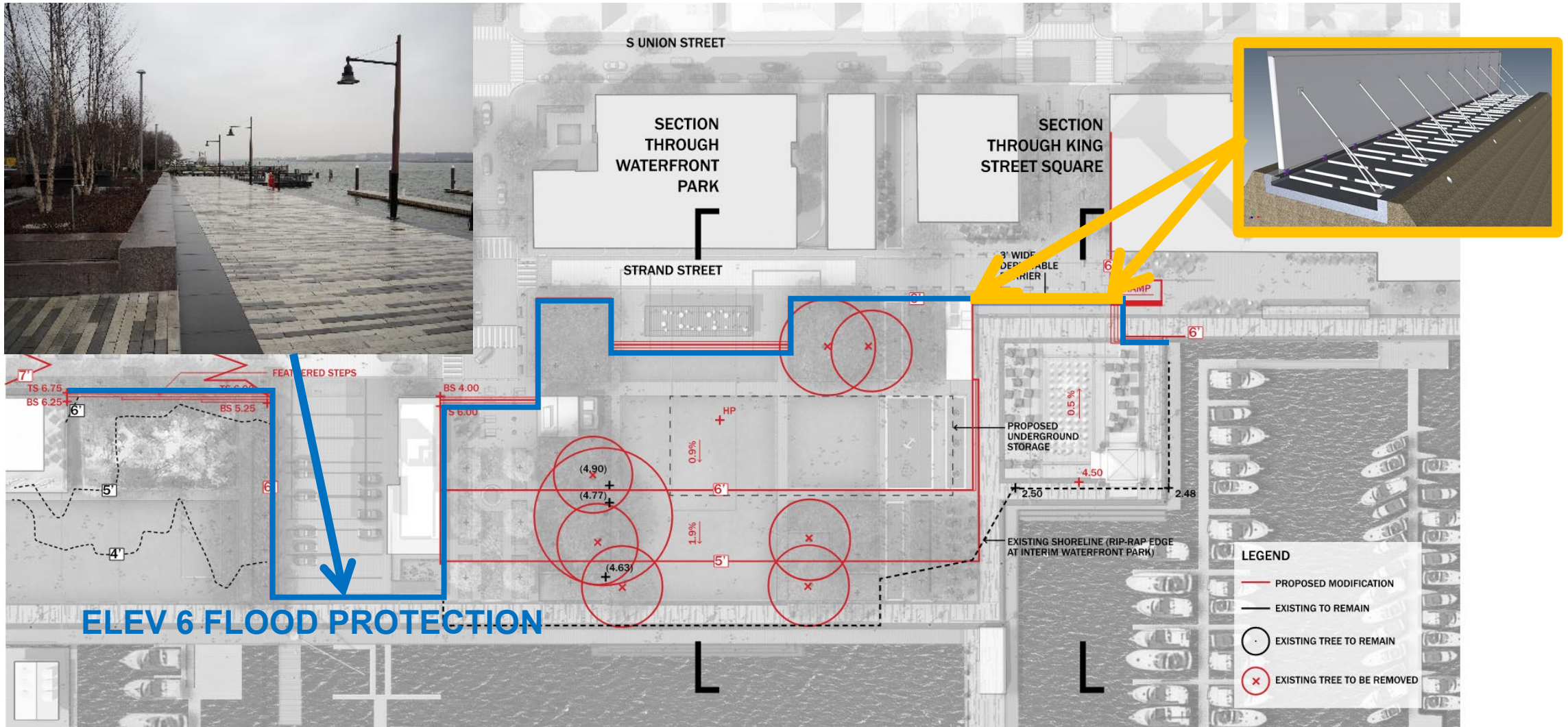

Flood Barriers – Option 5 Inland Flood Protection (Deployable at King Street Square)

SECTION THROUGH WATERFRONT PARK

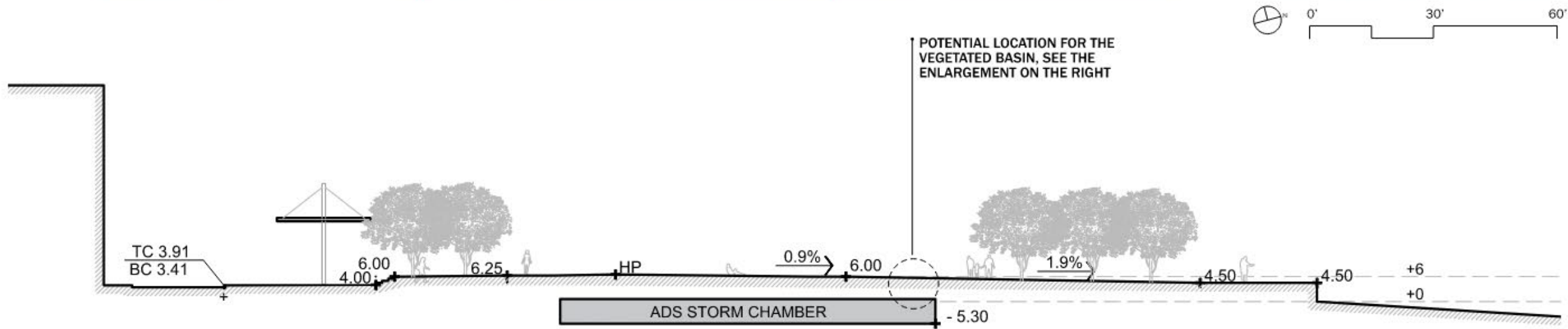
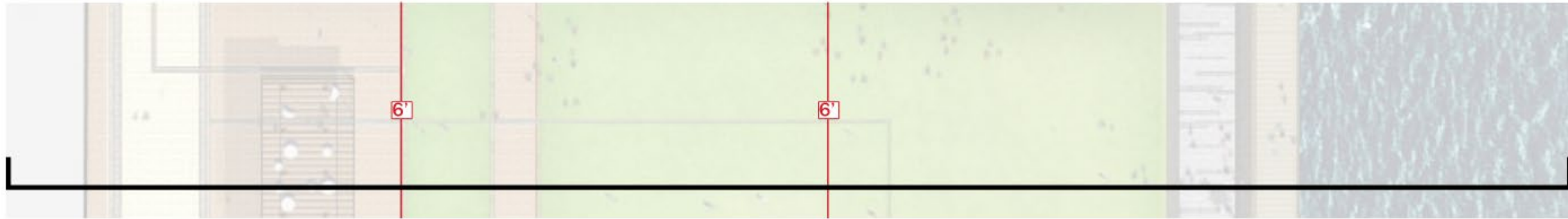

Flood Barriers – Option 5 Inland Flood Protection (Deployable at King Street Square)

SECTION THROUGH KING STREET SQUARE

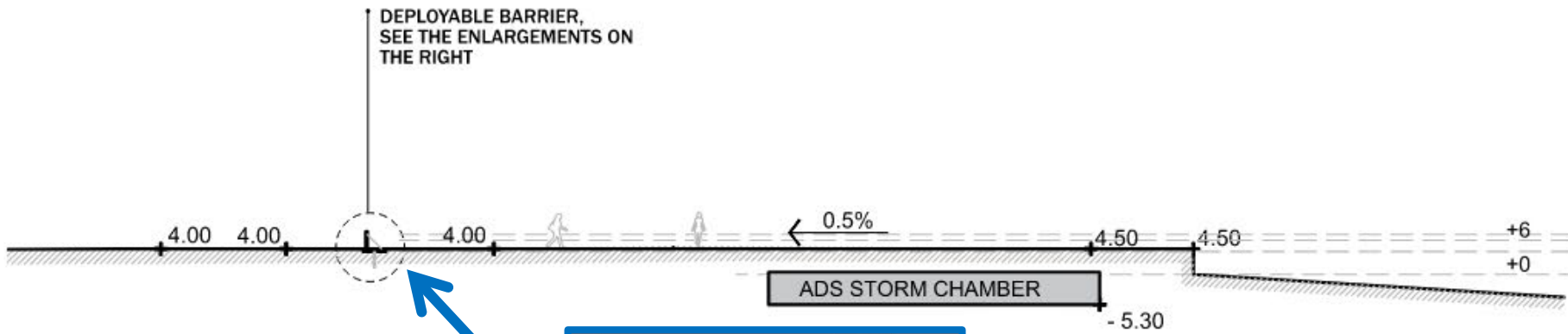

DEPLOYABLE BARRIER,
SEE THE ENLARGEMENTS ON
THE RIGHT

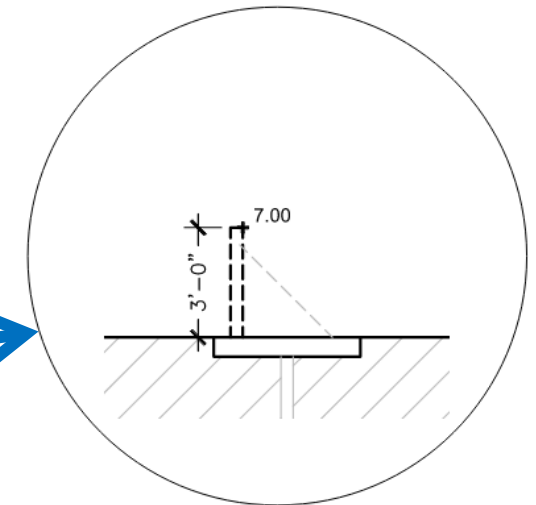
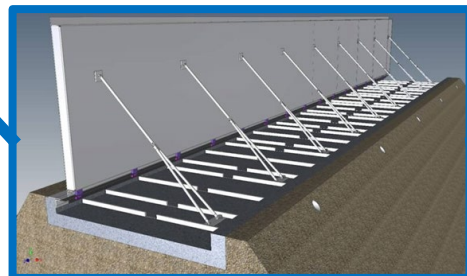

ENLARGEMENT AT THE DEPLOYABLE BARRIER

Potential Integrated Solutions

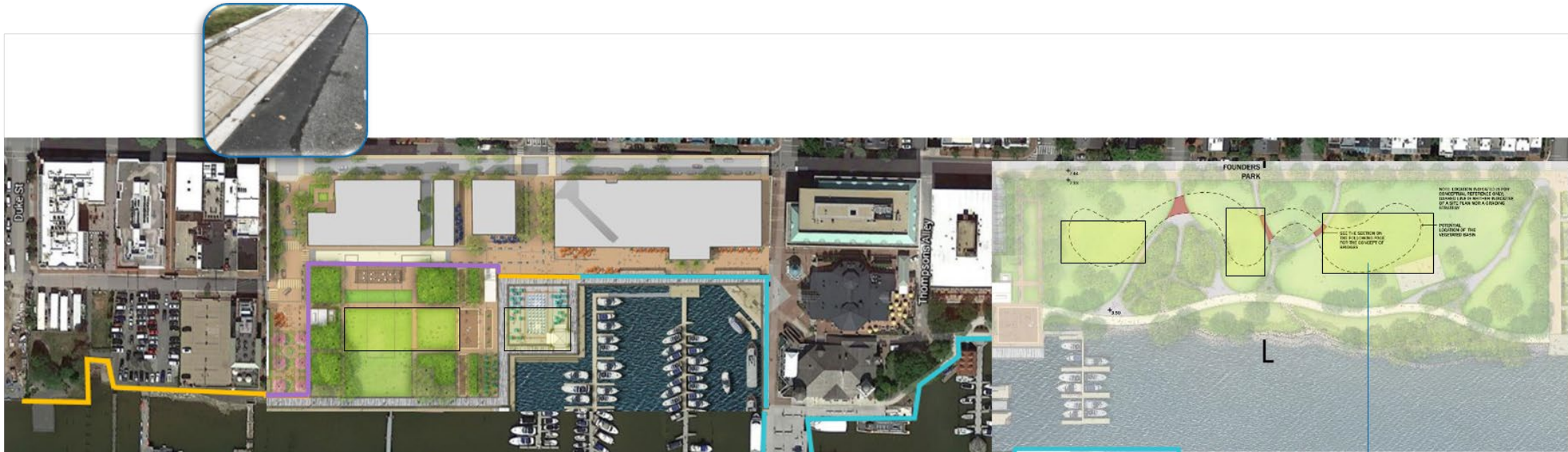

Hinged Barrier

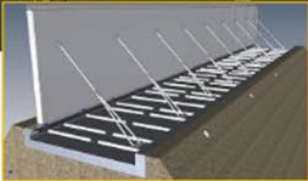

Ha-Ha Wall



Floodproof Glass



ALL REQUIRE ADDITIONAL ANALYSIS AND SITE INVESTIGATIONS

WITH FEEDBACK AND ADDITIONAL INFORMATION, TEAM WILL INTEGRATE ELEMENTS FROM ALL THREE TRACKS:

PROJECT PHASING



Could the Baseline Project be implemented over a longer time-period, and restrict the first phase to <\$102M?

VALUE ENGINEERING

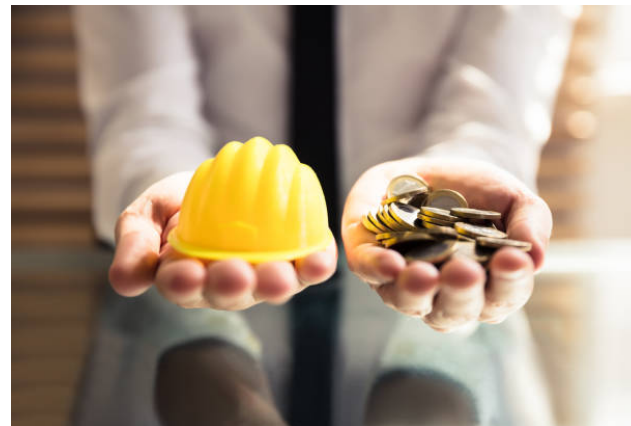

How might we value engineer the “big ticket” items (bulkhead, pump stations, and parks)?

ALTERNATIVE/ GREEN SOLUTIONS



How might green infrastructure offset the need for a new bulkhead and pump stations?

ALL REQUIRE ADDITIONAL ANALYSIS AND SITE INVESTIGATIONS



SUBCOMMITTEE FEEDBACK REQUESTED:

- Requesting Subcommittee feedback on alternatives concepts and approaches to:
 - **Stormwater management - Low Impact Development Strategies:**
 - Pervious pavement in public ROW/parking lane
 - Underground storage – Waterfront Park / Founders Park
 - Stormwater feature as Public Amenity – Founders Park
 - **Alternative flood protection strategies:**
 - Flood barriers:
 - Deployable products and technologies
 - Flood gates
 - Flood fence
 - Building flood proofing measures
 - Fixed Features (do not require activation/deployment)
 - Flood Glass Guardrail
 - Landscape site walls – amenity as infrastructure
 - **May provide feedback now, at next Subcommittee meeting, or via email to: Matthew Landes via email: Matthew.Landes@AlexandriaVA.gov**

Conceptual Development of Alternatives

Hydraulic Modeling

Hydraulic Modeling – Objectives and Outcomes

- XPSWMM Hydraulic Model
- **Confirm capacity** of core area existing storm sewer system
- **Identify ponding areas**, depth, and duration
- **Confirm** Project Baseline impact on mitigating flooding
 - Stantec Stormwater Management Plan Alternative 3B
- **Evaluate** flooding mitigation impact of modifications to project baseline
 - Underground Storage
 - Reduced Pump Station Sizes
 - Installation of flap valves at outfalls

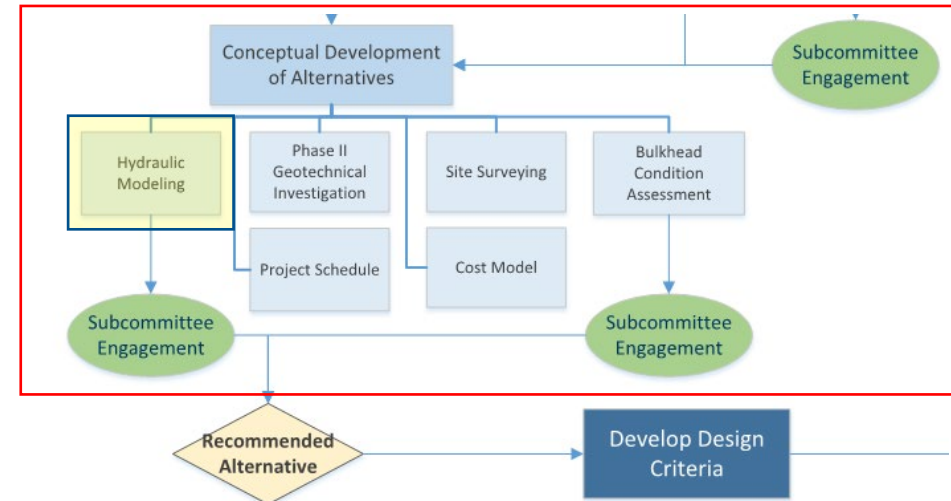

Hydraulic Review

Existing Condition in Old Town

- Three Sources of Flooding:
 - Tidal back-up
 - Overtopping of existing bulkhead
 - **Rainfall**
- Existing storm-sewer infrastructure is **significantly undersized**
- Installing backflow prevention at each outfall would eliminate tidal back-up, but would not improve wet-weather induced flooding
- Low points (El. < 3-ft NAVD88) along bulkhead are most vulnerable for overtopping

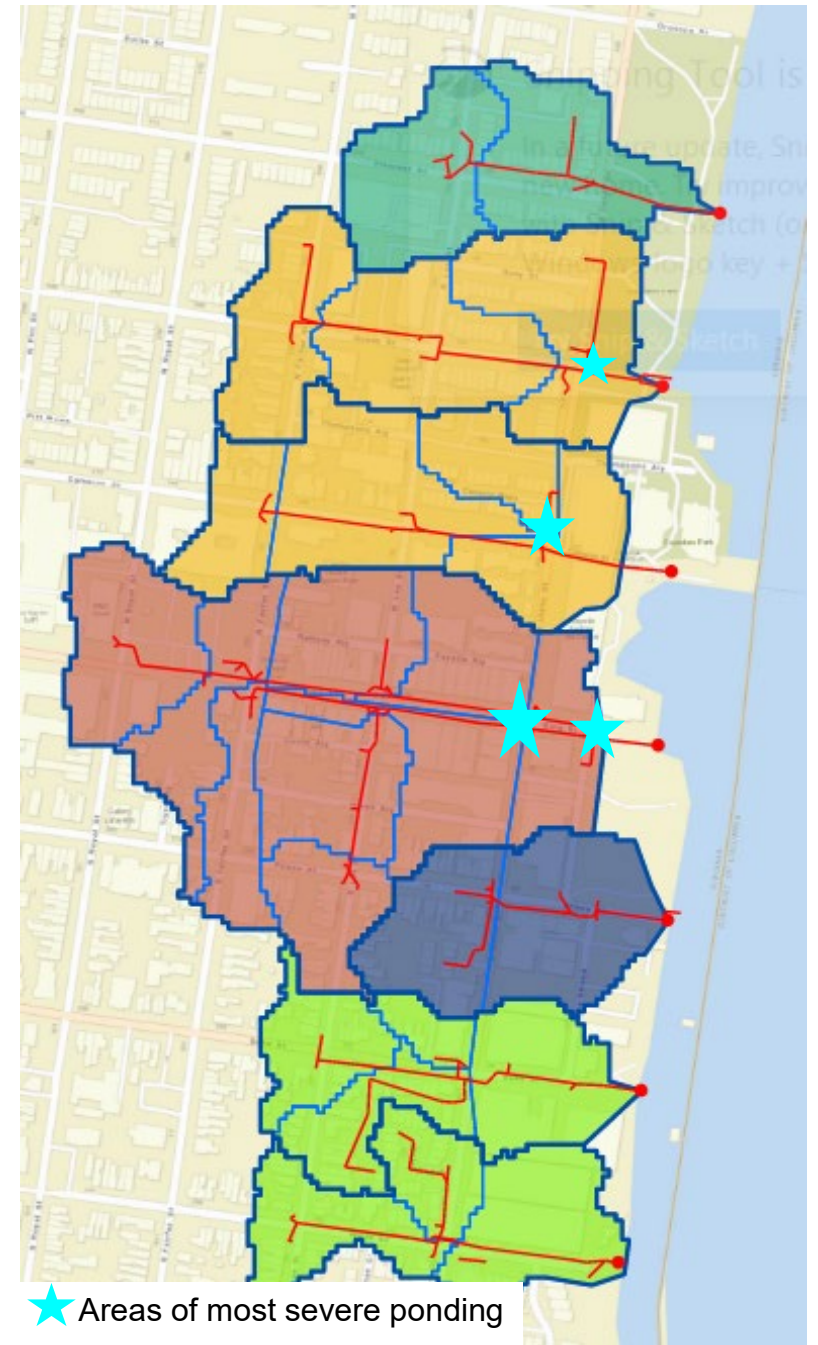

Design Storms and Impact on Flooding

Design	Design Storm	Storm Duration	Area of Analysis	Method of Evaluation
Baseline	10-year return Peak intensity is 9 in/hr	5-min	Core Area	MS Excel
Current		5-min*	Entire contributing catchment areas to each of the five outfalls designed within Core Area	XPSWM Model
		2-hour		
		24-hour		

- Dynamic and realistic storm durations
- Understand changes in flooding across entire catchment areas
- Assess the need to coordinate with City's ongoing storm capacity assessment and analysis.

*Used to validate the Stantec storm sewer design including sizing of pump stations

Design Storm Selection and Impact on Flooding

Design	Design Storm	Storm Duration	Area of Analysis	Method of Evaluation
Baseline	10-year, 9 in/hr	5-min	Core Area	MS Excel
Current		5-min*	Entire contributing catchment areas to each of the five outfalls designed within Core Area	XPSWMM Model
		2-hour		
		24-hour		

Selected

- Dynamic and **realistic** storm durations
- Understand changes in flooding across **entire** catchment areas

WILL CONTINUE TO MONITOR BEST PRACTICES/CLIMATE PROJECTIONS

*Used to validate the Stantec storm sewer design including sizing of pump stations

Project Baseline Calculations

Recurrence Interval (year)	Rainfall Intensity (inches / hour)	
	City IDF Curve	NOAA Atlas 14 IDF Curve
1	4.60	4.28
2	6.20	5.12
5	8.10	6.10
10	9.00	6.80
25	10.80	7.72
50	12.50	8.39
100	13.80	9.05
500	-	10.50
1000	-	11.20

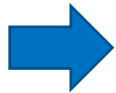

IDF = Intensity-Duration-Frequency

- Baseline Design Storm:
 - 10-year return period
 - Rainfall intensity: 9 in/hr
 - Event duration: 5 minutes
- Core Area



New Hydraulic Model Parameters

Recurrence Interval (year)	Rainfall Intensity (inches / hour)	
	City IDF Curve	NOAA Atlas 14 IDF Curve
1	4.60	4.28
2	6.20	5.12
5	8.10	6.10
10	9.00	6.80
25	10.80	7.72
50	12.50	8.39
100	13.80	9.05
500	-	10.50
1000	-	11.20

IDF = Intensity-Duration-Frequency

No Change to Storm Recurrence
& Rainfall Intensity

- Baseline Design Storm:
 - 10-year return period
 - Rainfall intensity: 9 in/hr
 - Event duration: **2 hours**

- **Extended Area**

Longer duration
& **Larger** area



Existing Stormwater Sewer System Capacity & Ponding Areas

10-year Storm, 9 in/hr. Intensity, 2-hr Duration, High Tide (3.6 ft.)

Existing



- Overwhelmed system due to **tidal back-up** and **stormwater runoff insufficient capacity**
- Water cannot evacuate Core Area until tide lowers

Up to 1-ft flooding along Union St

Up to 3-ft flooding at King St & Strand Intersection

Up to 1.5-ft flooding at Prince St behind bulkhead

Project Baseline Stormwater Sewer System Capacity & Ponding Areas

10-year Storm, 9 in/hr. Intensity, 2-hr Duration*, High Tide (3.6 ft.)

Existing



Baseline



- Up to 8-inches of overland flooding
- Water will run across surface until it reaches an available inlet
- Subsides < 1hr

Tidal induced flooding at high tide

*5-min duration eliminates flooding within Core Area

Model Verification against Historical Data – Year 2018

Model Comparisons:

- Existing, Baseline & Proposed Design Conditions Model:
 - Model-built Storm Return Period: **10-yr storm (COA IDF)**
 - Model-built Storm Intensity: **9 in/hr.** [Peak 5-min period: **2.21 in/hr.**]
 - Model-built Storm Duration: **2 hours**
- 2018: **“Worst Year”** based on total annual rainfall for period 1948-2019
 - Storm Return Period in 2018: up to **50-yr storm**
 - Storm Intensity in 2018: up to approx. **2.75 in/hr.**
 - Storm Duration in 2018: **1 hour** (actual duration)
- 2013: “Typical Year” based on total annual rainfall for period 1948-2018
 - Storm Return Period in 2013: **1 – 5 yr. storm (NOAA)**
 - Max. Storm Intensity in 2013: **1.2 in/hr.**
 - Storm Duration in 2013: **Actual Duration** (rainfall data)
- Greatest Historical Storm Intensity (1948 – 2018): **3.29 in/hr.** July 22, 1969
- Year 2100 Climate Change SimCLIM Model Projected Storm Intensity : **7.84 in/hr.** (5-min. duration)

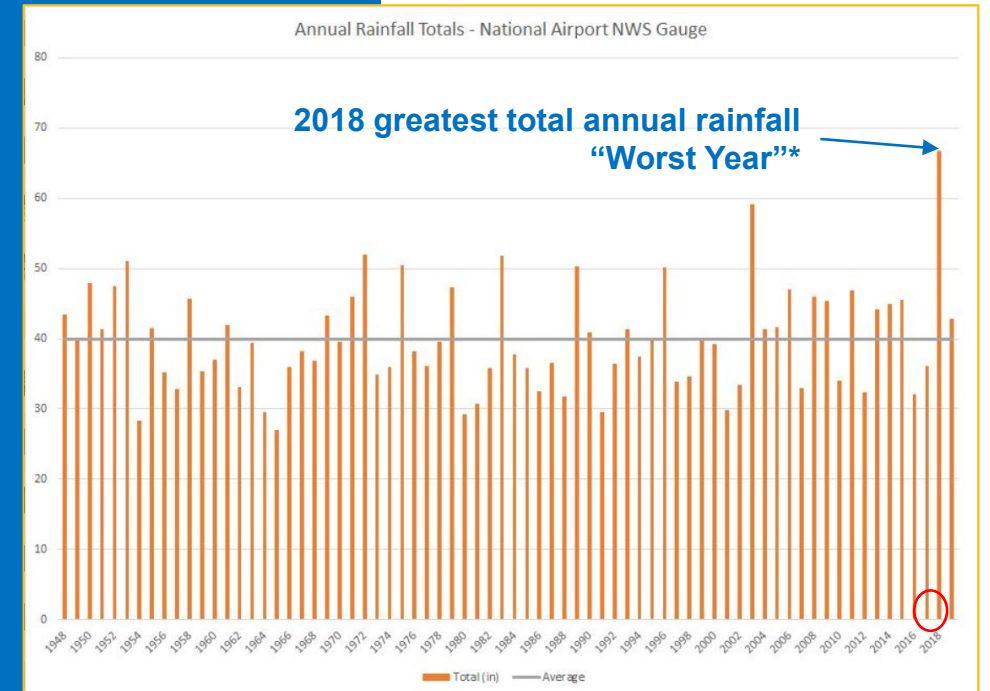

*Year 2018 “Worst Year” **66.2 inches** total annual rainfall compared to **39.8 inches** annual average

Existing Condition and Frequency of Flooding for the 2-hour storm duration

Intersection	Return Interval	Annual Probability of Occurrence	Max Depth of Ponding	Duration of Total Ponding
1 King & Union	1-year	100%	1 – 1.5'	1:48
	2	50%	1 – 1.5'	1:50
	5	20%	1.5 – 2'	1:54
	10	10%	1.5 – 2'	1:56
	2018 Storm	N/A	1 - 1.5'	~ 1 hr.
2 Union b/w Cameron & Queen	1-year	100%	0.5 – 1'	0:56
	2	50%	1 – 1.5'	1:00
	5	20%	1 – 1.5'	1:08
	10	10%	1 – 1.5'	1:18
	2018 Storm	N/A	0.5 - 1'	~ 1hr.

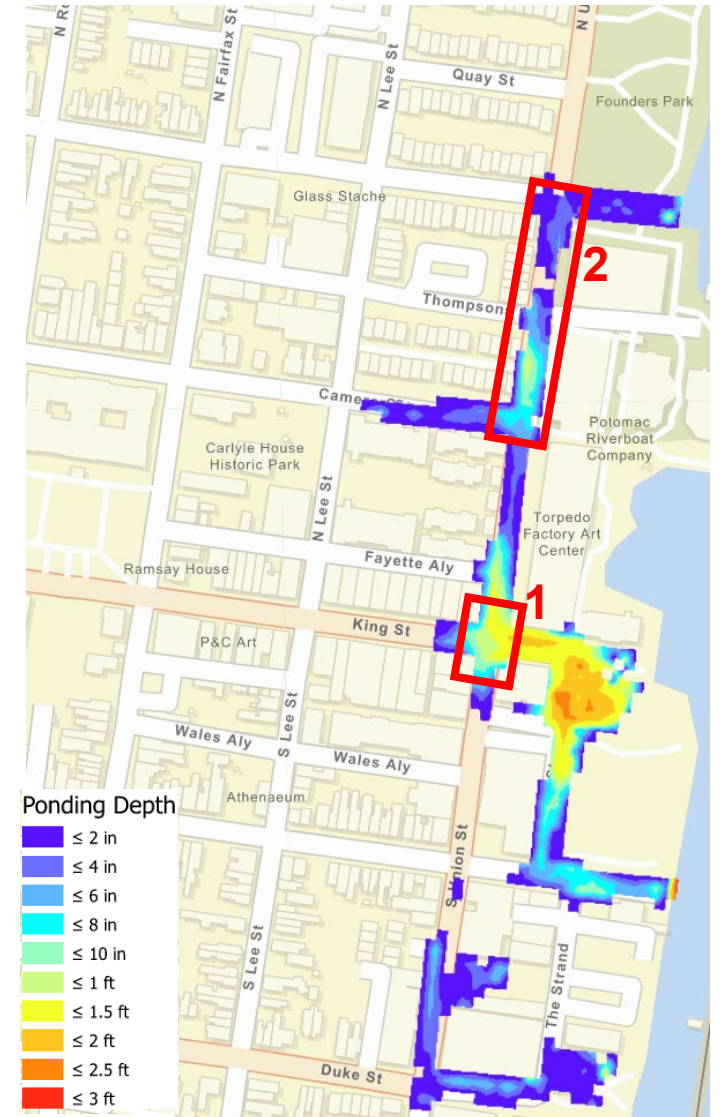

Proposed Sewer Improvements with Underground Storage and Frequency of Flooding for the 2-hour storm duration

Intersection	Return Interval	Annual Probability of Occurrence	Max Depth of Ponding	Duration of Total Ponding
1 King & Union	1-year	100%	1 – 1.5'	1:48
	2	50%	1 – 1.5'	1:50
	5	20%	1.5 – 2'	1:54
	10	10%	1.5 – 2'	1:56
	2018 Storm	N/A	None	--
2 Union b/w Cameron & Queen	1-year	100%	0.5 – 1'	0:56
	2	50%	1 – 1.5'	1:00
	5	20%	1 – 1.5'	1:08
	10	10%	1 – 1.5'	1:18
	2018 Storm	N/A	None	--

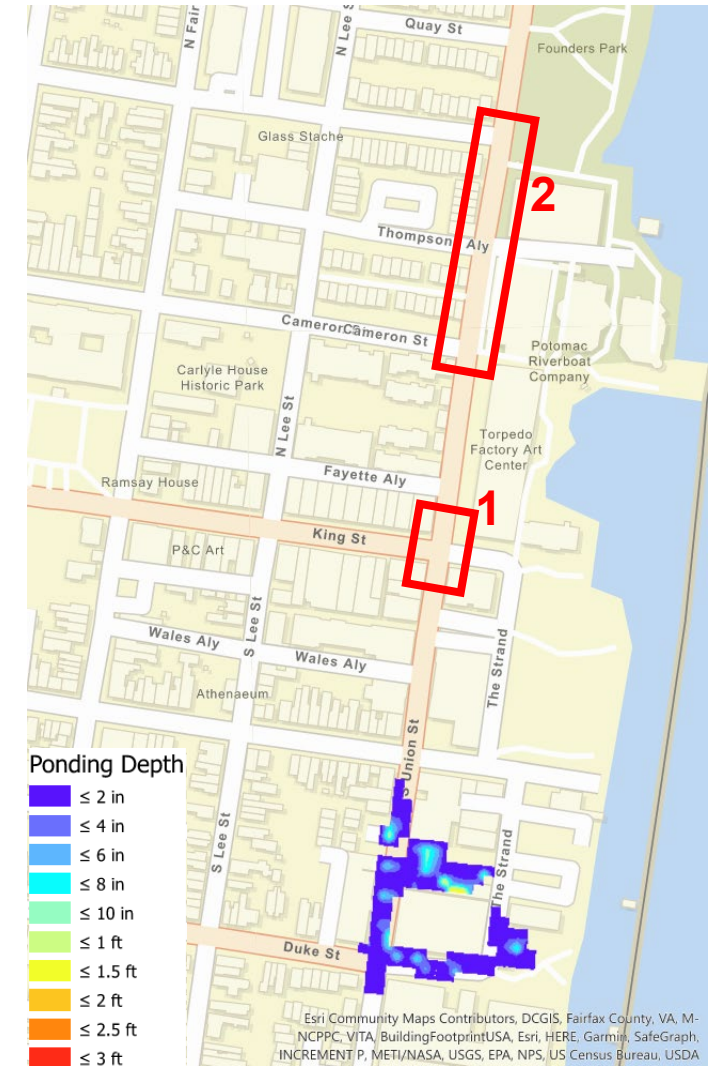

Conclusions

- Low Impact Development should be included where viable; however, will not significantly reduce the need for other mitigation strategies.
 - Streetscape solutions may be limited by available corridor space and historical considerations.
- **Underground storage has potential to greatly reduce the need for large pump stations.**
 - Impact is tripled if we can retrofit additional storage under Founder's Park.
 - Above-ground rainwater features provide additional capacity but sacrifice green space.
- **Alternative approaches to Flood Barriers and Flood Protection may save up-front costs and allow for phasing, resilience, and greater cost-benefit**



Next Steps / Schedule

- Immediate Next steps:
 - Additional community engagement
 - Next subcommittee meeting: June 7th - Virtual
 - Geotechnical testing and structural analysis
 - Refinement of alternatives based on:
 - Modeling
 - Cost-benefit analysis
 - Engineering studies
 - Community feedback
 - Integration of Phasing, Value Engineering, and Alternatives
- Anticipated Project Timeline*:
 - Additional Investigations and Modeling / Cost-Benefit Analysis - 24 – 36 weeks to complete
 - Alternatives/Public Input –
 - Scope of work aligned to priorities
 - PDB RFQ development: present – Mid-2022
 - Cost-Benefit Analysis
 - Criteria development to qualify PDB
 - Industry outreach
 - Updates to Council and Waterfront Commission
 - PDB procurement: Late 2022
 - PDB phase 1 (design): Late 2022-2023
 - Negotiate GMP: Late 2023-2024
 - PDB phase 2 (construction): Early-mid 2024
 - Site Construction: mid-2024 through mid 2027

*Schedule subject to change to accommodate community feedback and civic engagement and/or changes to CIP funding schedule



SUBCOMMITTEE FEEDBACK REQUESTED:

- Requesting Subcommittee feedback on alternatives concepts and approaches to:
 - **Stormwater management - Low Impact Development Strategies:**
 - Pervious pavement in public ROW/parking lane
 - Underground storage – Waterfront Park / Founders Park
 - Stormwater feature as Public Amenity – Founders Park
 - **Alternative flood protection strategies:**
 - Flood barriers:
 - Deployable products and technologies
 - Flood gates
 - Flood fence
 - Building flood proofing measures
 - Fixed Features (do not require activation/deployment)
 - Flood Glass Guardrail
 - Landscape site walls – amenity as infrastructure
 - **May provide feedback now, at next Subcommittee meeting, or via email to: Matthew Landes via email: Matthew.Landes@AlexandriaVA.gov**