

COORDINATED SIGN PROGRAM
INOVA ALEXANDRIA
AT LANDMARK

November 9, 2023

TABLE OF CONTENTS

3	Introduction	15	A1.1 - Brand ID, Façade
4	Wayfinding Analysis	16	A1.3 - Brand ID, Façade
5	Sign Location Plan Overview	17	A3.1 - Site ID, Landscape
6	Sign Location Plan A	18	A3.2 - Site ID, Landscape
7	Sign Location Plan B	19	A4.2 - Building ID, Letters
8	Sign Location Plan C	20	A5.2 - Emergency Building ID, Letters
9	Sign Location Plan D	21	A5.4 - Emergency Building ID, Canopy Letters
10	Sign Location Plan E	22	A6.1 - Building ID, Freestanding
11	Sign Location Plan F	23	A8.1 - Secondary Building Entrance ID
12	Illumination	24	A10.1 - Building Address ID
13	Signage Family	25	A11.1 - Building Entrance Number
		26	A12.1 - Park ID, Freestanding
		27	A12.2 - Park ID, Non-Regulatory, Freestanding
		28	A16.1 - Parking ID, Digital
		29	A16.2 - Parking ID, Digital / Directional
		30	A18.1 - Parking ID, Letters
		31	A18.2 - Parking Entrance / Exit, Letters
		32	B1.1 - Vehicular Directional, Freestanding
		33	B1.2 - Vehicular Directional, Freestanding
		34	B1.3 - Vehicular Directional, Freestanding
		35	B1.4 - Vehicular Directional, Freestanding (Alt)
		36	B2.1 - Pedestrian Directional & Map, Freestanding
		37	B3.1 - Valet ID / Drop-Off ID
		38	R8.3 - Entrance Information

INTRODUCTION

The Inova Alexandria Hospital at Landmark will be a key part of the WestEnd district. This Coordinated Sign Program provides the strategy and components of the wayfinding and identification required to make the Hospital campus, including the Hospital, the Cancer Center, and the Health Center, function for patients, visitors, and Inova team members. Wayfinding concepts and sign design for the Inova Alexandria Campus are part of new Inova Health System standards, to be implemented at all Inova facilities, creating a uniform patient and visitor experience and a consistent visual identity across all locations. The standards have been developed using a rigorous design review process, including industry standards for text size and full scale physical mockups to ensure legibility and visibility.

Identification signs are carefully scaled for all users: from drivers traveling on Interstate 395 or Duke Street, to pedestrians entering the campus from adjacent WestEnd facilities. Wayfinding signs within the campus are strategically placed and messaging has been coordinated for consistency and clarity.

This Plan demonstrates the particular circulation, parking, and drop off needs for the Hospital campus, illustrates the Inova brand, aesthetic, and explains the unique function, design, and architectural integration of each sign type.







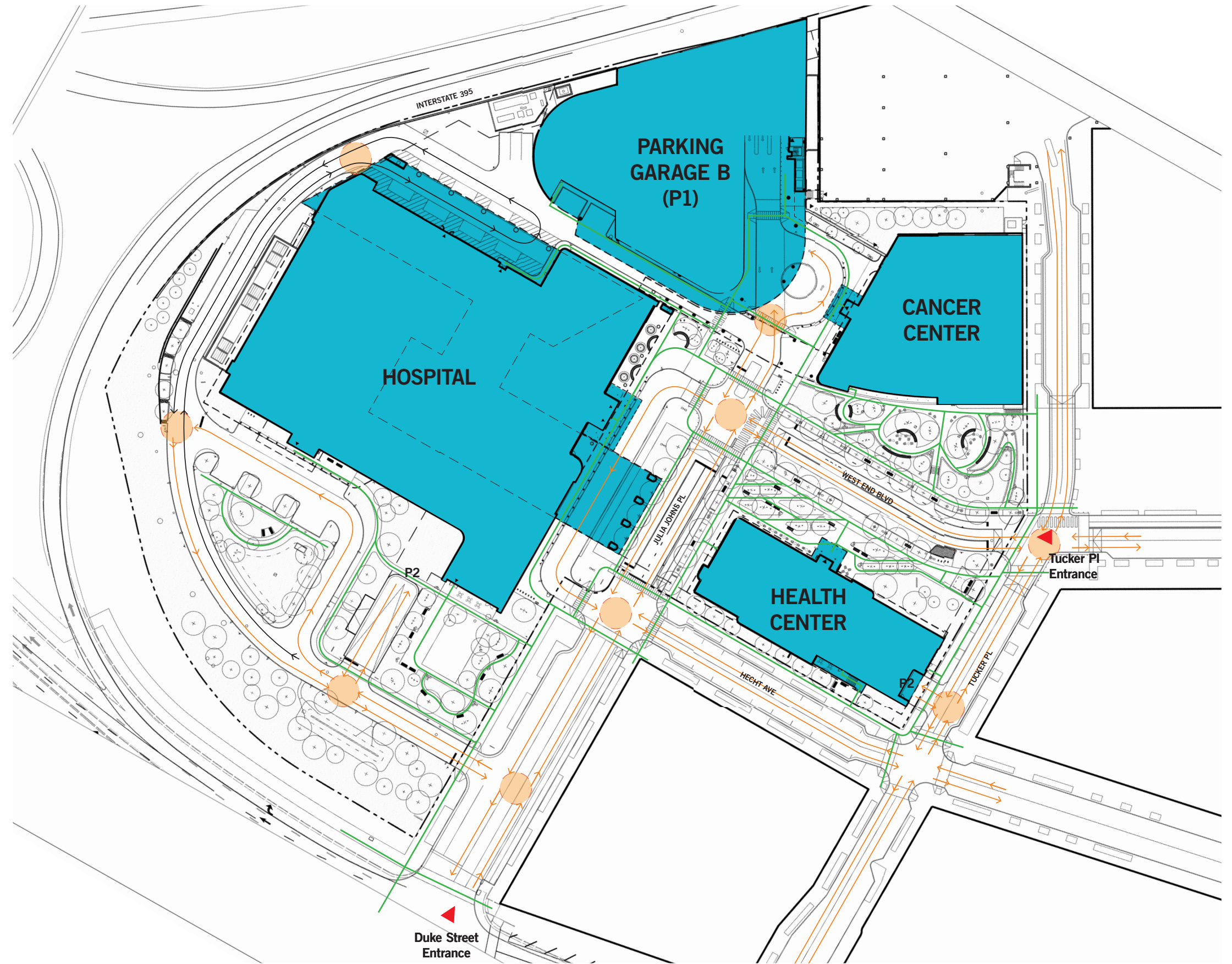

WAYFINDING ANALYSIS

The Coordinated Sign Program for Inova Alexandria at Landmark must provide for ease of access into and out of specific facilities on the Hospital campus. The unique mix of vehicular and pedestrian circulation, from Interstate highway to dense urban grid, necessitates a variety of approaches.

Julia Johns Place serves as the main north-south thoroughfare with its entrance off of Duke Street is the anticipated “front door” for vehicular access to the site. Slower moving vehicular traffic and pedestrians will approach the site from Hecht Avenue or West End Boulevard.

Clear and consistent directional signs are required at each intersection. Vehicles coming to the Hospital campus will be parking in one of the garages, dropping off or picking up patients and visitors, or delivering patients via ambulance. Emergency drop off will be clearly distinguished from other destinations. Exits will also be frequently indicated on directional signs for ease of egress from the site.



FLOW LEGEND			
	Decision Point		Vehicular Flow
	Site Entrance		Emergency Vehicular Flow
			Pedestrian Flow

SIGNAGE LOCATION PLAN OVERVIEW

All exterior signs included in the Coordinated Sign Program for Inova Alexandria at Landmark are indicated on this location plan. These include building mounted and freestanding signs used for both wayfinding and identification.

Sign types are indicated with a unique code (e.g. A1.1, B1.2, etc.). The Sign Family is summarized on the next two pages, followed by descriptions for each unique sign type.

LEGEND	QTY
A1.1 Brand ID, Façade	5
A1.3 Brand ID, Façade	4
A3.1 Site ID, Landscape	1
A3.2 Site ID, Landscape	1
A4.2 Building ID, Letters	3
A5.2 Emergency Bldg ID, Letters	2
A5.4 Emergency Bldg ID, Canopy Letters	1
A6.1 Building ID, Freestanding	4
A8.1 Secondary Building Entrance ID	4
A10.1 Building Address ID	4
A11.1 Building Entrance Number	27
A12.1 Park ID, Freestanding	1
A12.2 Park ID Non-Regulatory, Freestanding	6
A16.1 Parking ID, Digital	2
A16.2 Parking ID, Digital / Directional	1
A18.1 Parking ID, Letters	4
A18.2 Parking Entrance/Exit, Letters	4
B1.1 Vehicular Directional, Freestanding	7
B1.2 Vehicular Directional, Freestanding	6
B1.3 Vehicular Directional, Freestanding	1
B1.4 Vehicular Directional, Freestanding (Alt)	8
B2.1 Pedestrian Directional & Map, Freestanding	11
B3.1 Valet ID / Drop-Off ID	4
R8.3 Entrance Information	10

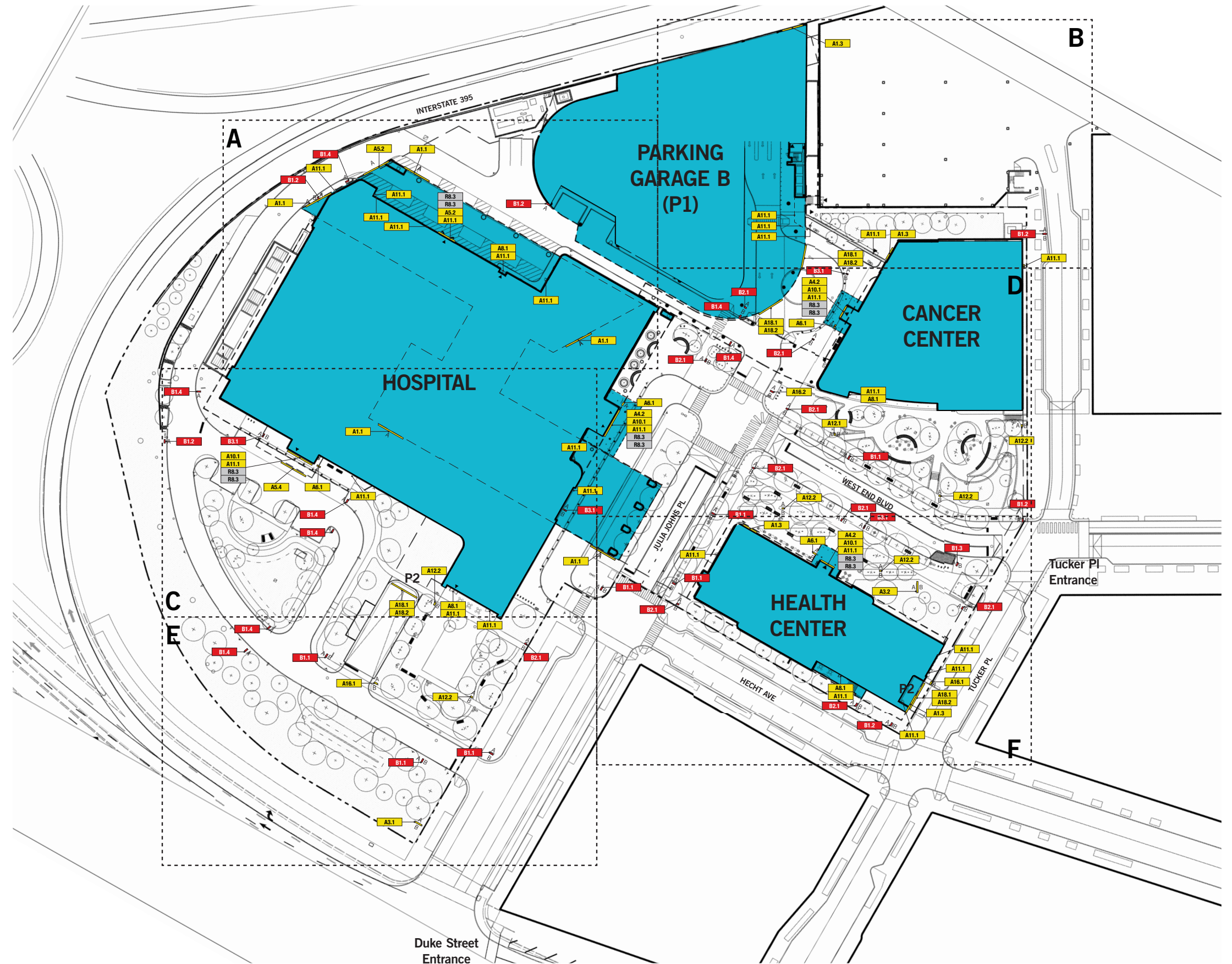

SIGNAGE LOCATION PLAN A

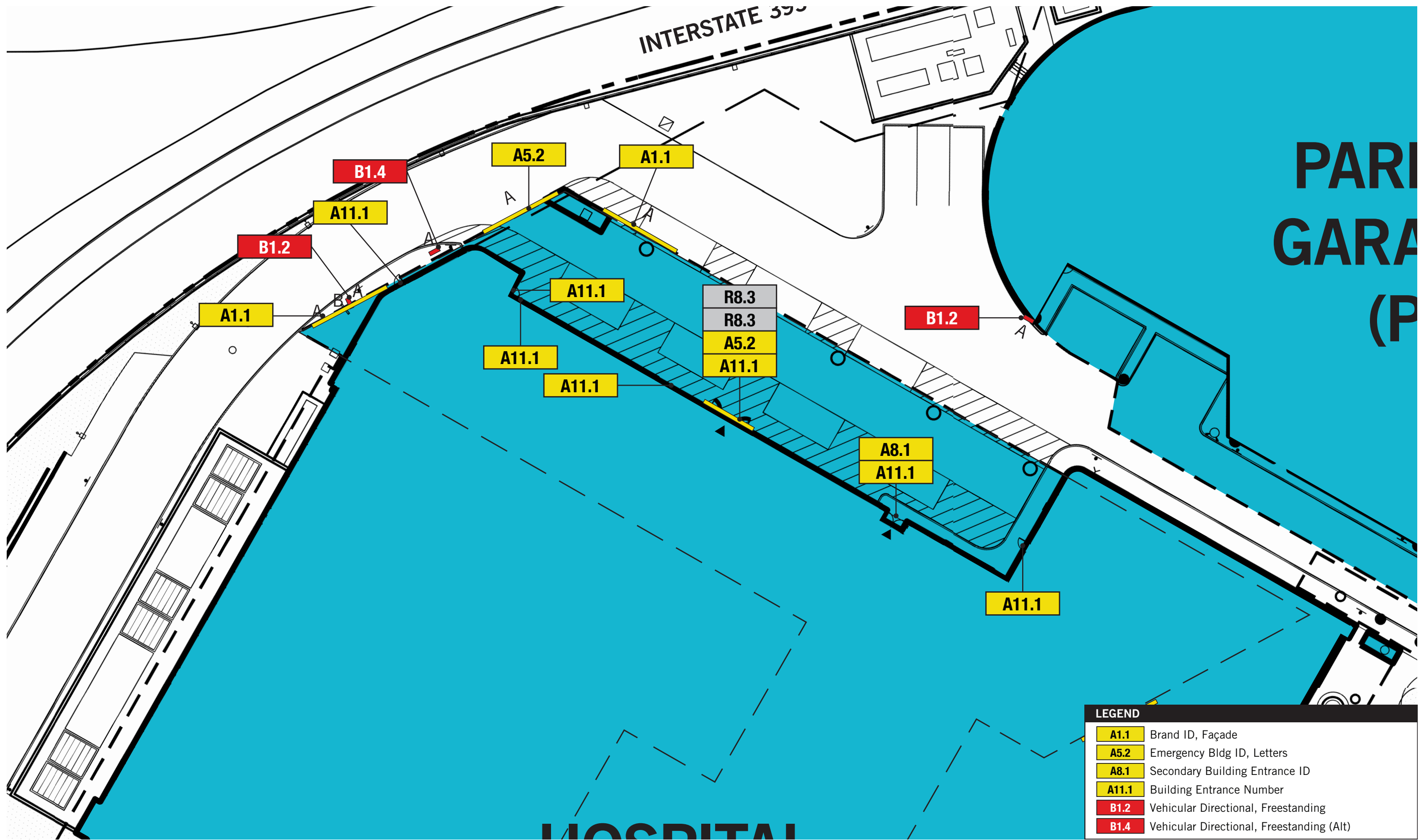

SIGNAGE LOCATION PLAN B

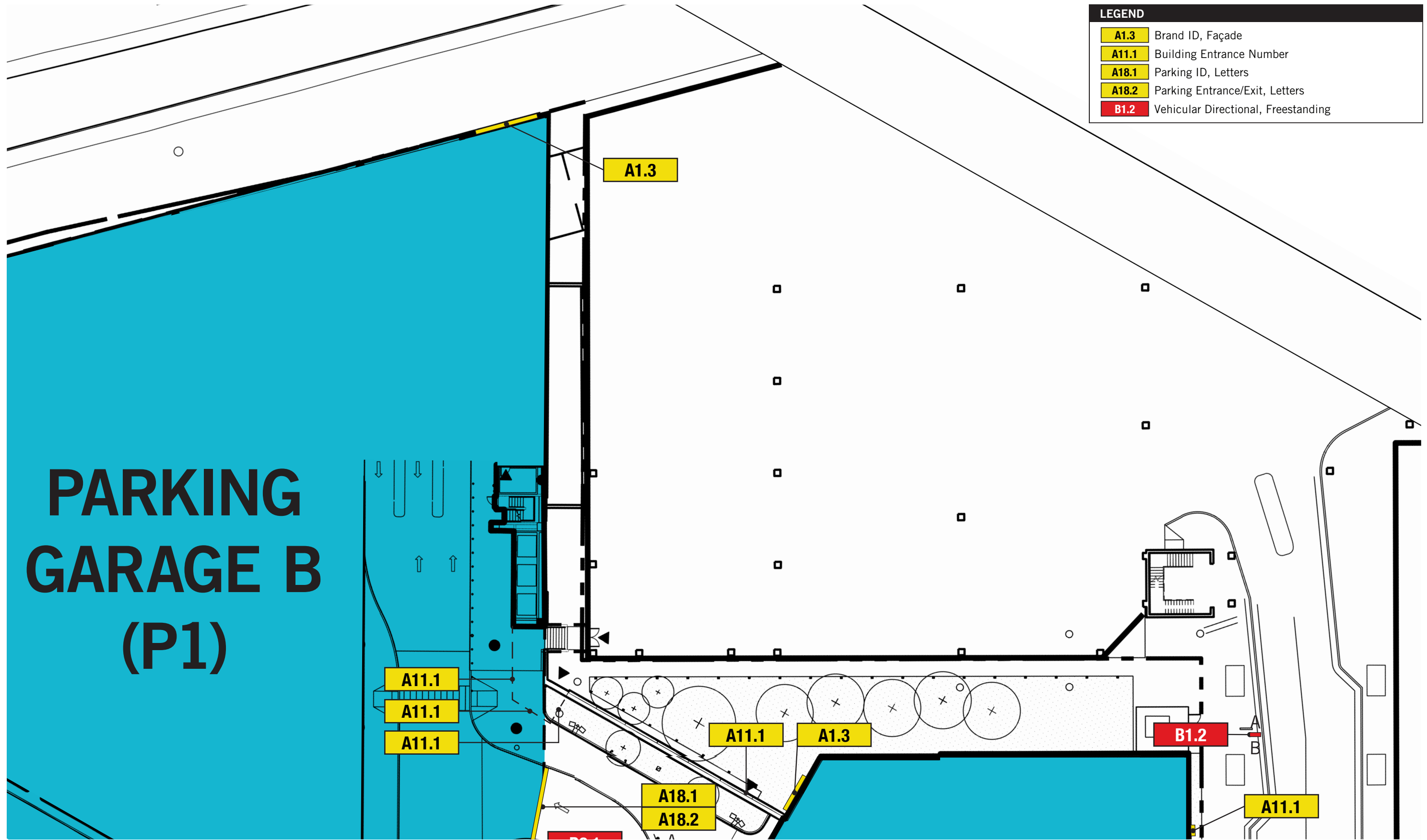

SIGNAGE LOCATION PLAN C

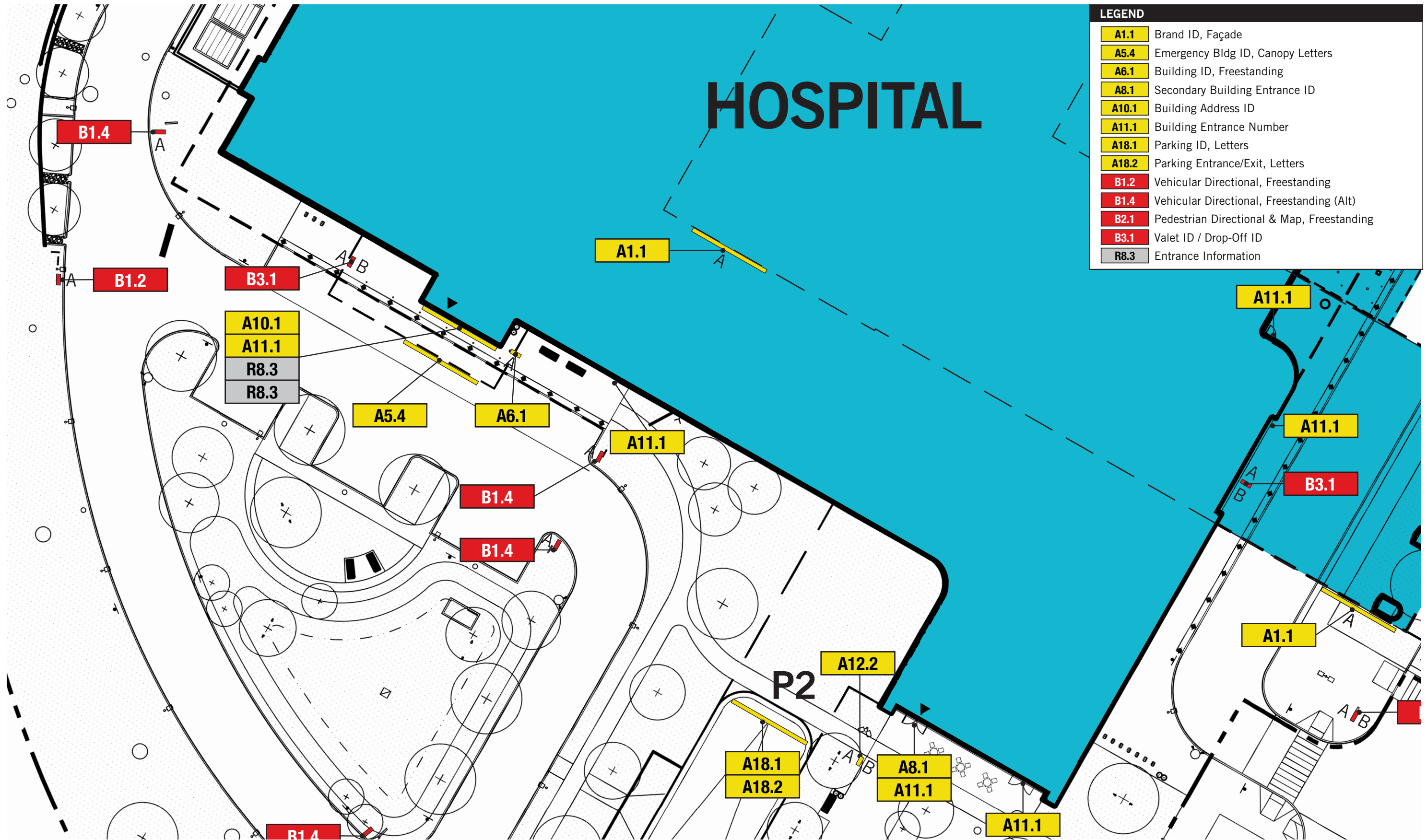

SIGNAGE LOCATION PLAN D

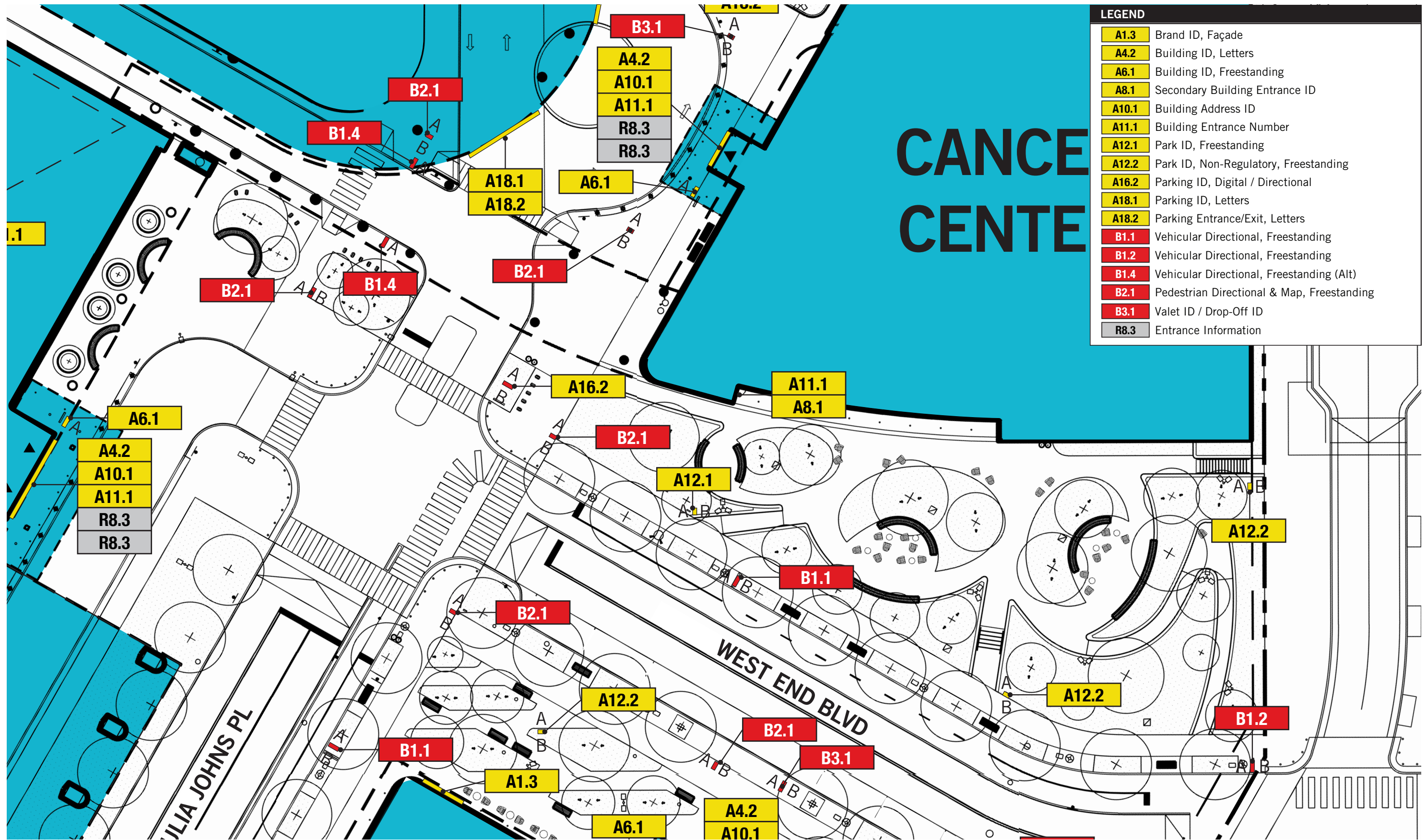

SIGNAGE LOCATION PLAN E

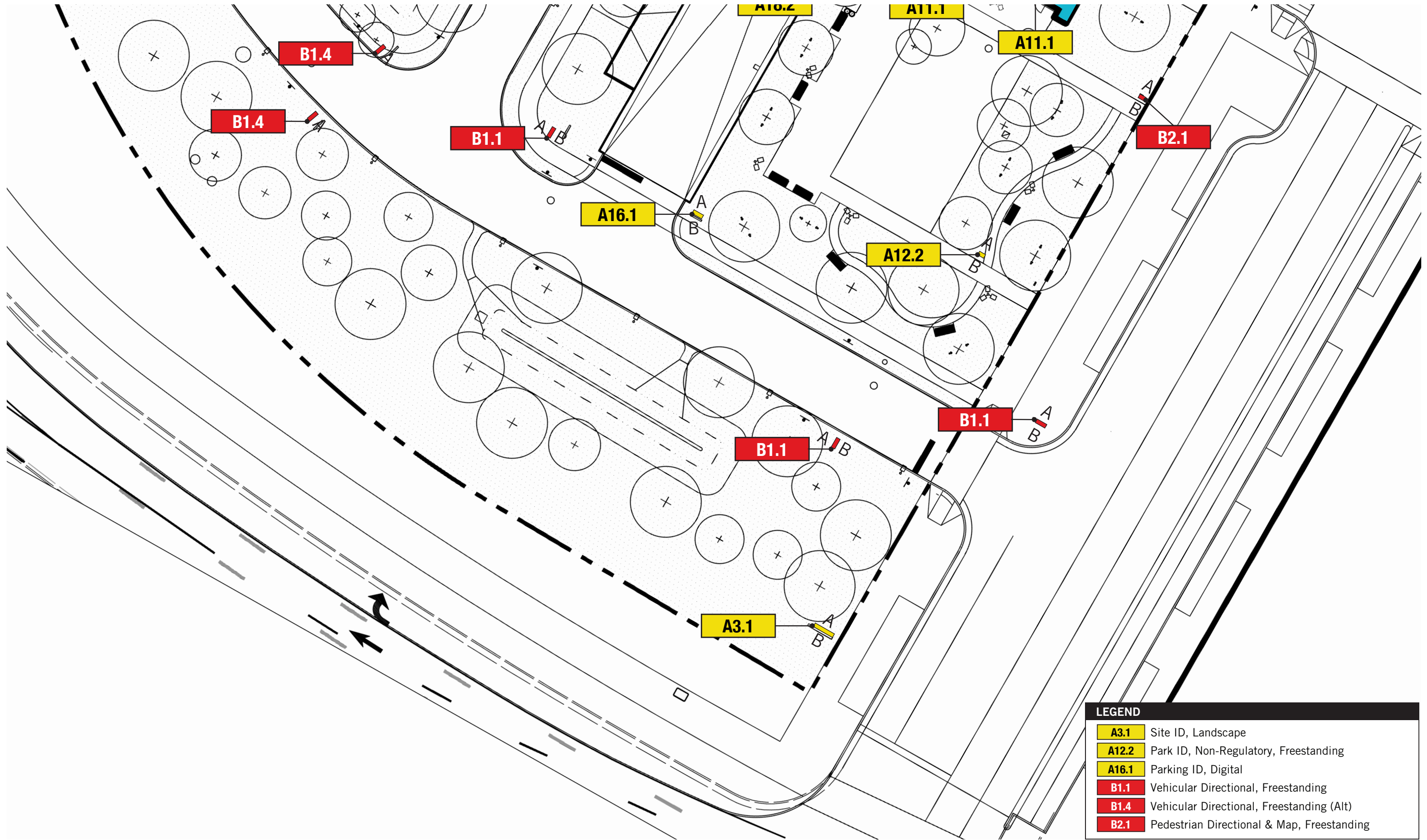

LEGEND	
A3.1	Site ID, Landscape
A12.2	Park ID, Non-Regulatory, Freestanding
A16.1	Parking ID, Digital
B1.1	Vehicular Directional, Freestanding
B1.4	Vehicular Directional, Freestanding (Alt)
B2.1	Pedestrian Directional & Map, Freestanding

SIGNAGE LOCATION PLAN F

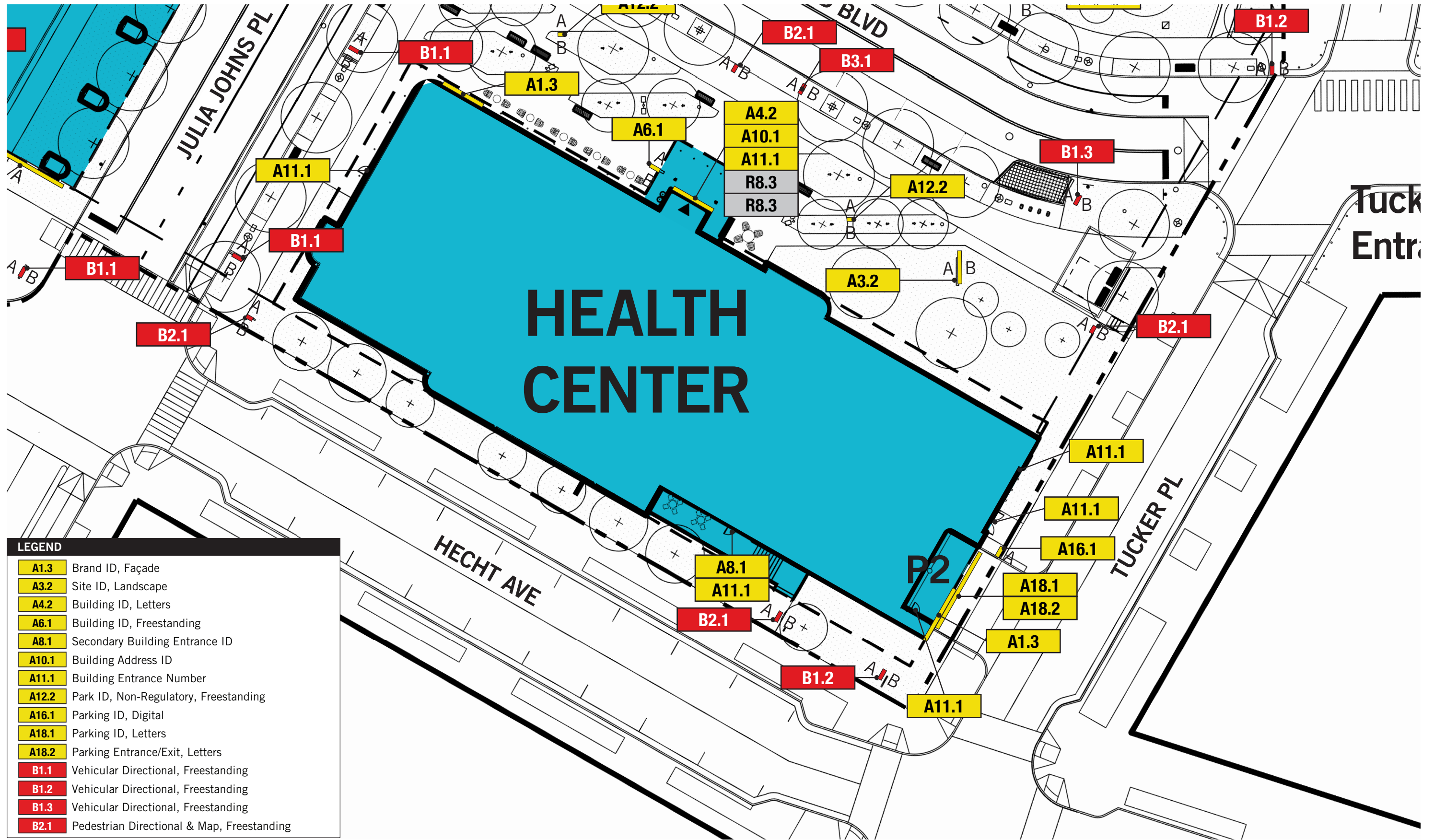

LEGEND

A1.3	Brand ID, Façade
A3.2	Site ID, Landscape
A4.2	Building ID, Letters
A6.1	Building ID, Freestanding
A8.1	Secondary Building Entrance ID
A10.1	Building Address ID
A11.1	Building Entrance Number
A12.2	Park ID, Non-Regulatory, Freestanding
A16.1	Parking ID, Digital
A18.1	Parking ID, Letters
A18.2	Parking Entrance/Exit, Letters
B1.1	Vehicular Directional, Freestanding
B1.2	Vehicular Directional, Freestanding
B1.3	Vehicular Directional, Freestanding
B2.1	Pedestrian Directional & Map, Freestanding

ILLUMINATION

Free-standing Signs

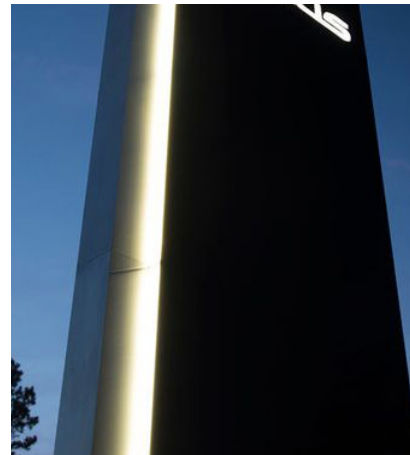

Halo-lit sign panel



In-ground up lighting



Digital display (A16.1)
Toggles between OPEN/FULL
& parking spots available

Channel Letters



White illuminated face with
gray returns

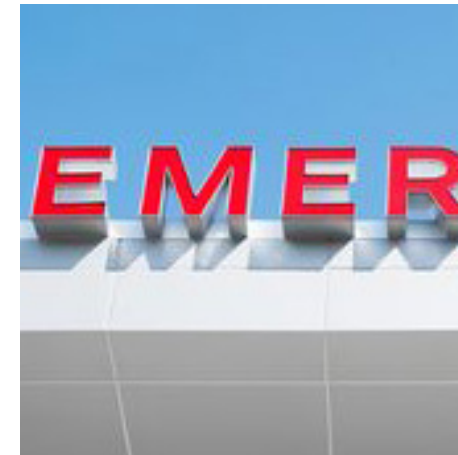

Red face with gray returns

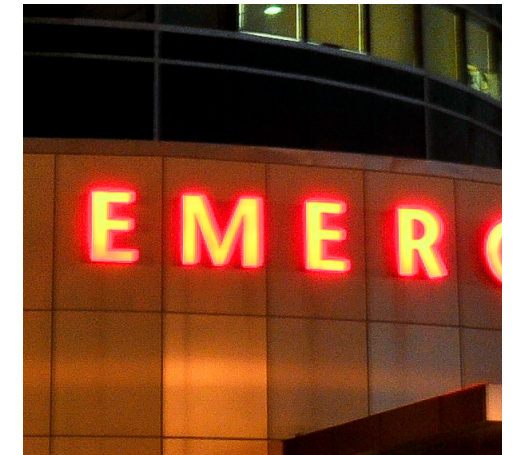

Red illuminated face with gray
returns



Standard lighting intent for Inova free-standing sign



Sign curvature detail



SIGNAGE FAMILY



A1.1 - Brand ID, Façade

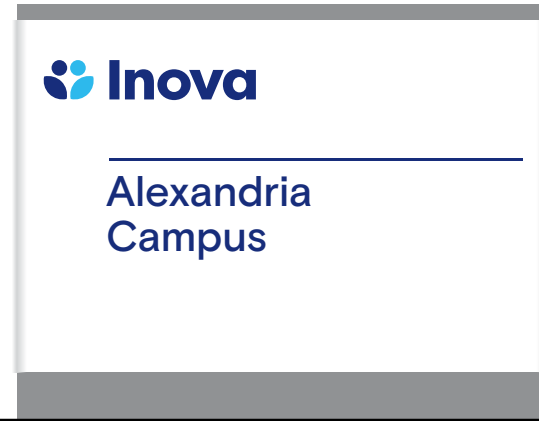
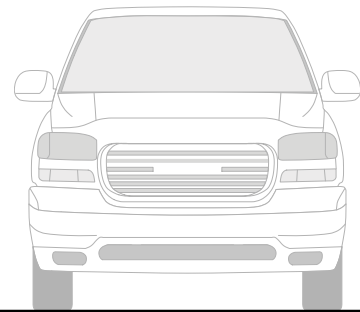

A3.1 - Site ID, Landscape

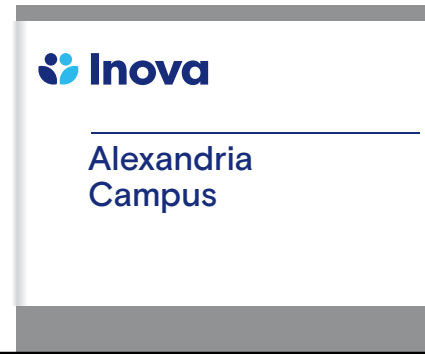

A3.2 - Site ID, Landscape

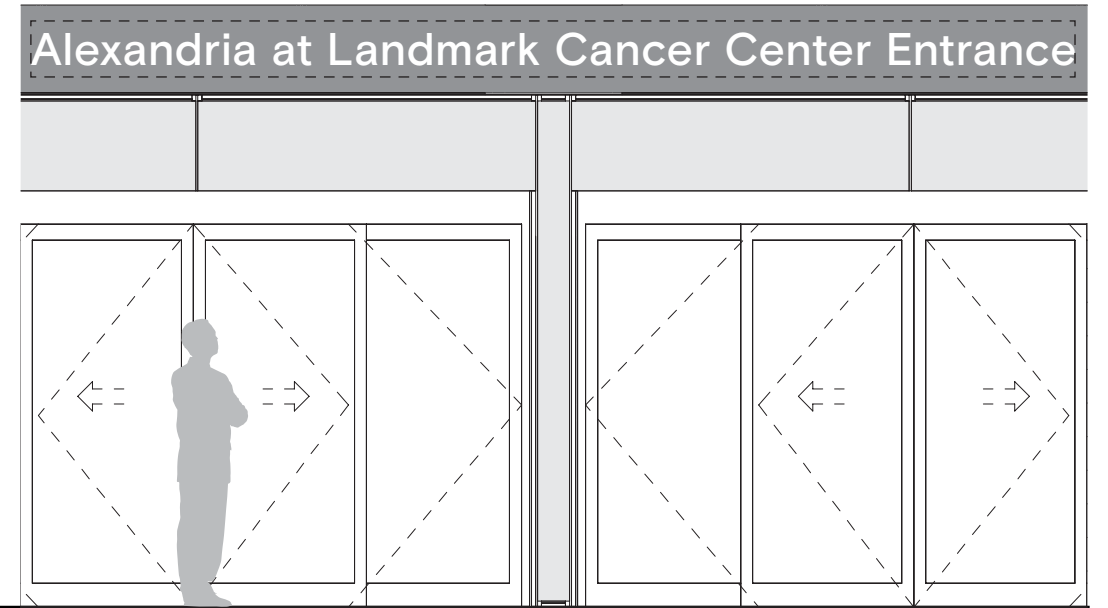

A4.2 - Building ID, Letters



A5.2 - Emergency Building ID, Letters

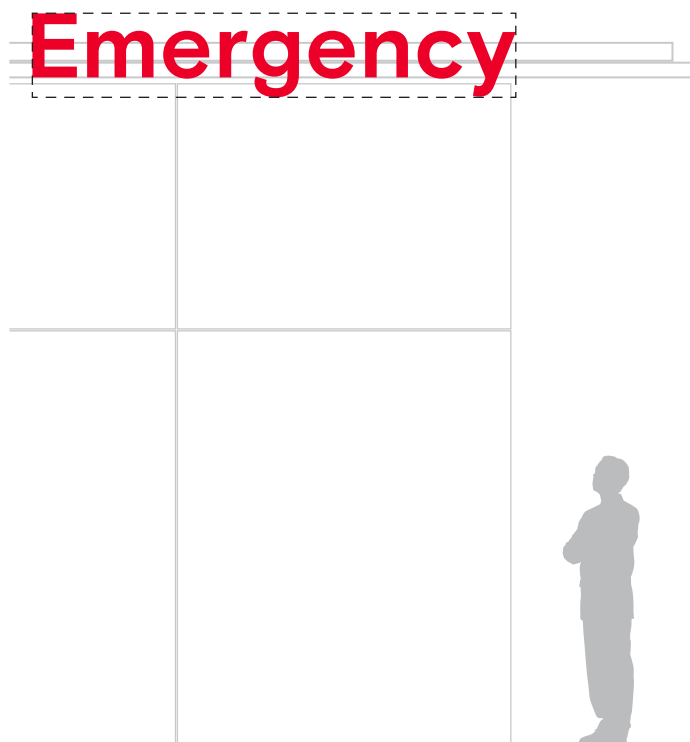

A5.4 - Emergency Building ID, Canopy Letters



A6.1 - Building ID, Freestanding



A8.1 - Secondary Building Entrance ID

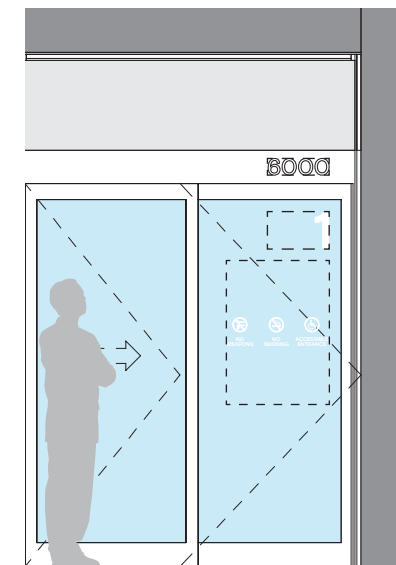

A10.1 - Building Address ID
A11.1 - Building Entrance Number
R8.3 - Entrance Information

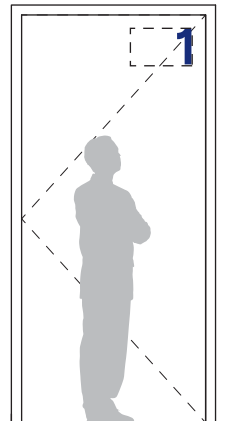

A11.1 - Building Entrance Number (Alternative)

SIGNAGE FAMILY

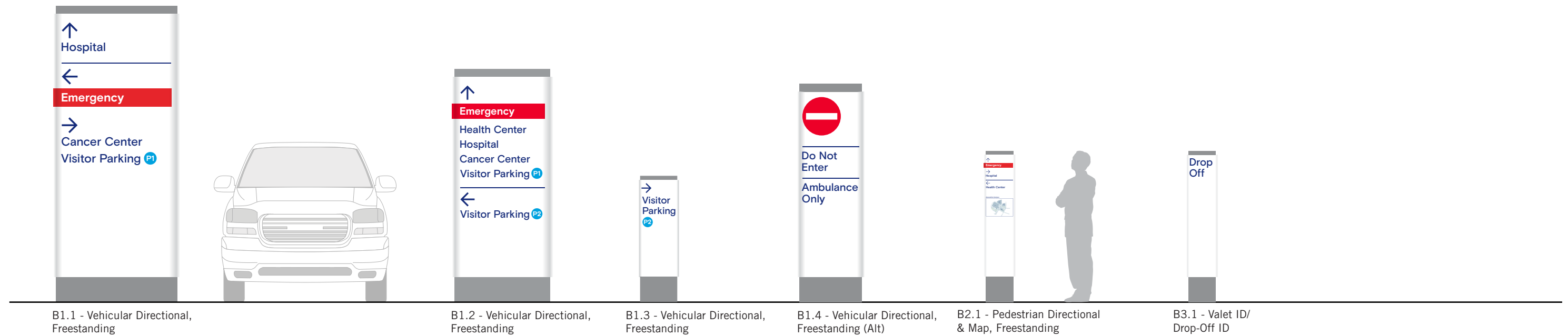
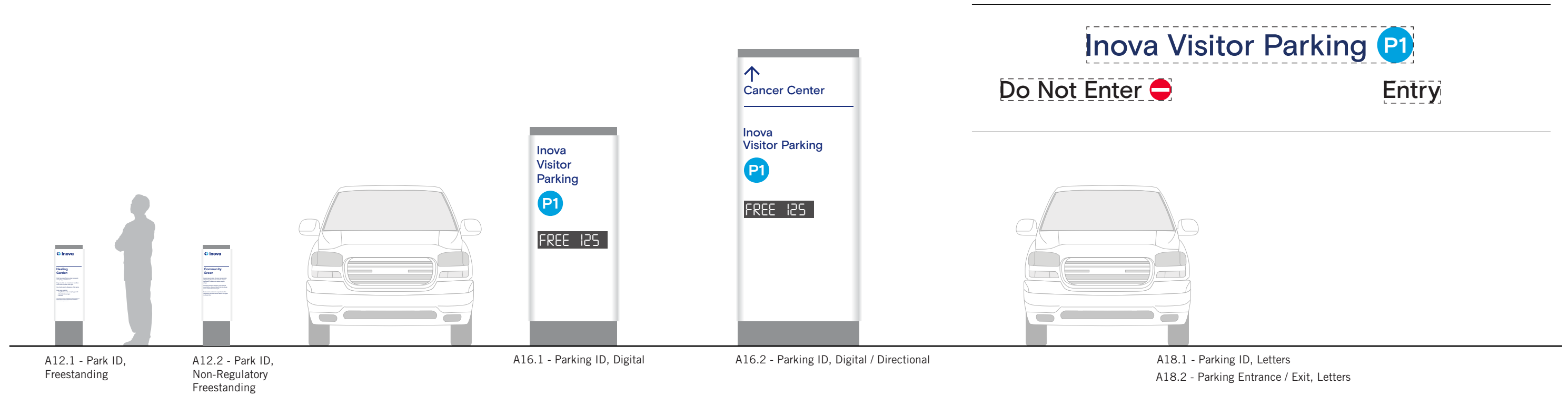

A1.1 - BRAND ID, FAÇADE

QTY: 5

Building mounted signs are located at facades facing the major vehicular routes approaching the site, specifically along Interstate 395 and Duke Street.

Design Specifications

- Dimensions: 31'-10" w x 6'-0" h, Sign Area: 191 sqft.
- Internally illuminated LED Channel Letters with painted gray metal returns, Inova branded blue faces during day and illuminated faces at night.
- Face of letters sit 5-inches proud of building facade.

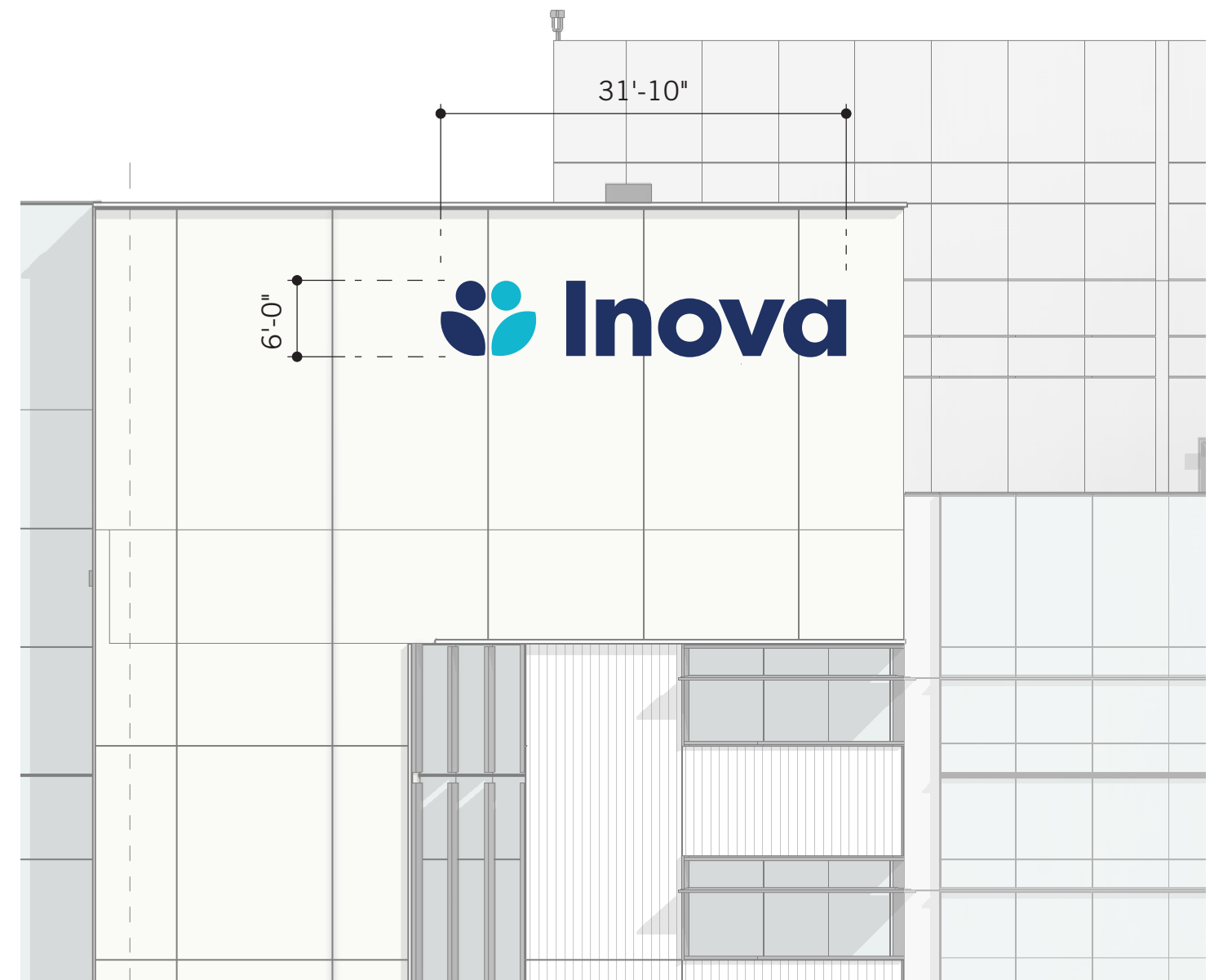

A1.3 - BRAND ID, FAÇADE

QTY: 4

A similar large building mounted sign is located on the following facades: the Parking Garage and Cancer Center visible to traffic traveling along Interstate 395, the Health Center east facade visible along Tucker Place and Hecht Avenue (where pedestrians walk from the transit hub), and the Health Center north facade visible from West End Boulevard and Julia Johns Place.

In these cases, design studies concluded that a slightly smaller logo and wordmark height fits the designated location for this sign.

Design Specifications

- Dimensions: 18'-6"w x 3'-6"h, Area: 64.75 sqft.
- Internally illuminated LED Channel Letters with painted gray metal returns, Inova branded blue faces during day and illuminated white faces at night.
- Face of letters sit 5-inches proud of building facade.

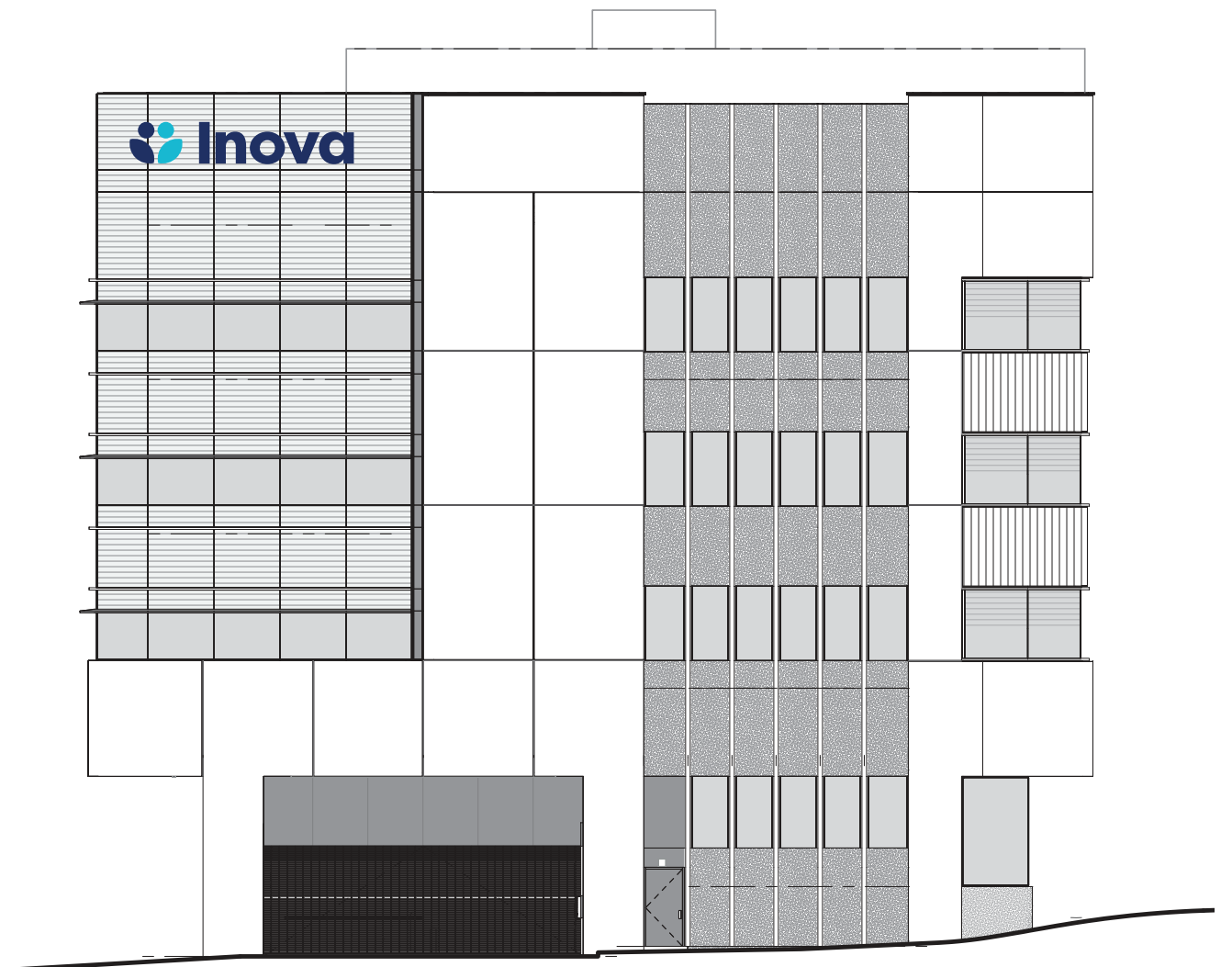
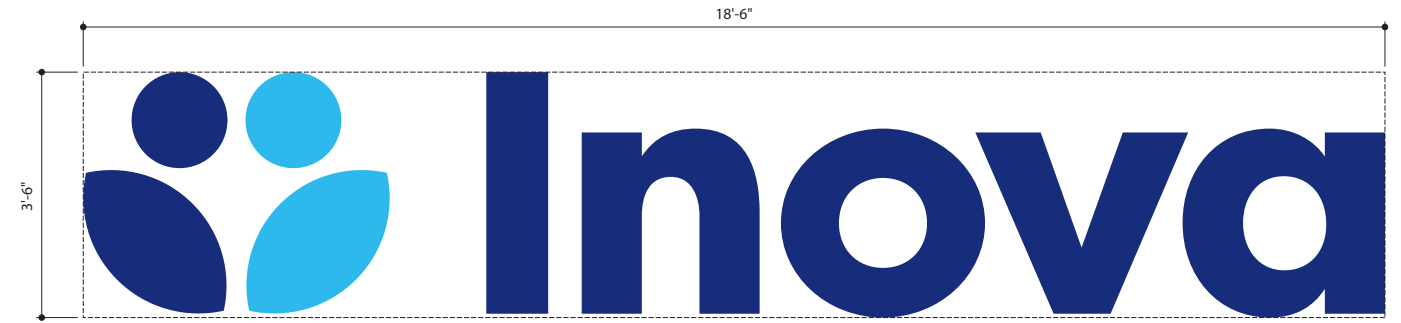

A3.1 - SITE ID, LANDSCAPE

QTY: 1

A freestanding monument sign located at the Duke Street entrance. This sign serves as the “front” entrance confirmation for drivers entering both the Inova Landmark campus and the WestEnd district.

The horizontal orientation of this sign is intended to distinguish the Inova campus identification from the WestEnd district identification monument signs programmed for the corner across Julia Johns Place.

Design Specifications

- Dimensions: 11'-3"w x 8'-8"h, Sign Area: 97.5 sqft.
- Double-sided free-standing sign with halo-lit painted metal sign panels applied to front and back sides of concrete sign core.
- External in-ground uplighting to illuminate graphics on sign panel(s).

Sign messages shown on elevation for design intent only. Final content TBD.



A3.2 - SITE ID, LANDSCAPE

QTY: 1

A freestanding monument sign located at the West End Boulevard and Tucker Street entrance. This sign has been scaled down from the Duke Street identification sign due to the denser, more pedestrian-oriented character of this entrance.

Design Specifications

- Dimensions: 9'-0" w x 7'-3" h, Sign Area: 65.25 sqft.
- Double-sided free-standing sign with halo-lit painted metal sign panels applied to front and back sides of concrete sign core.
- External in-ground uplighting to illuminate graphics on sign panel(s).

Sign messages shown on elevation for design intent only. Final content TBD.

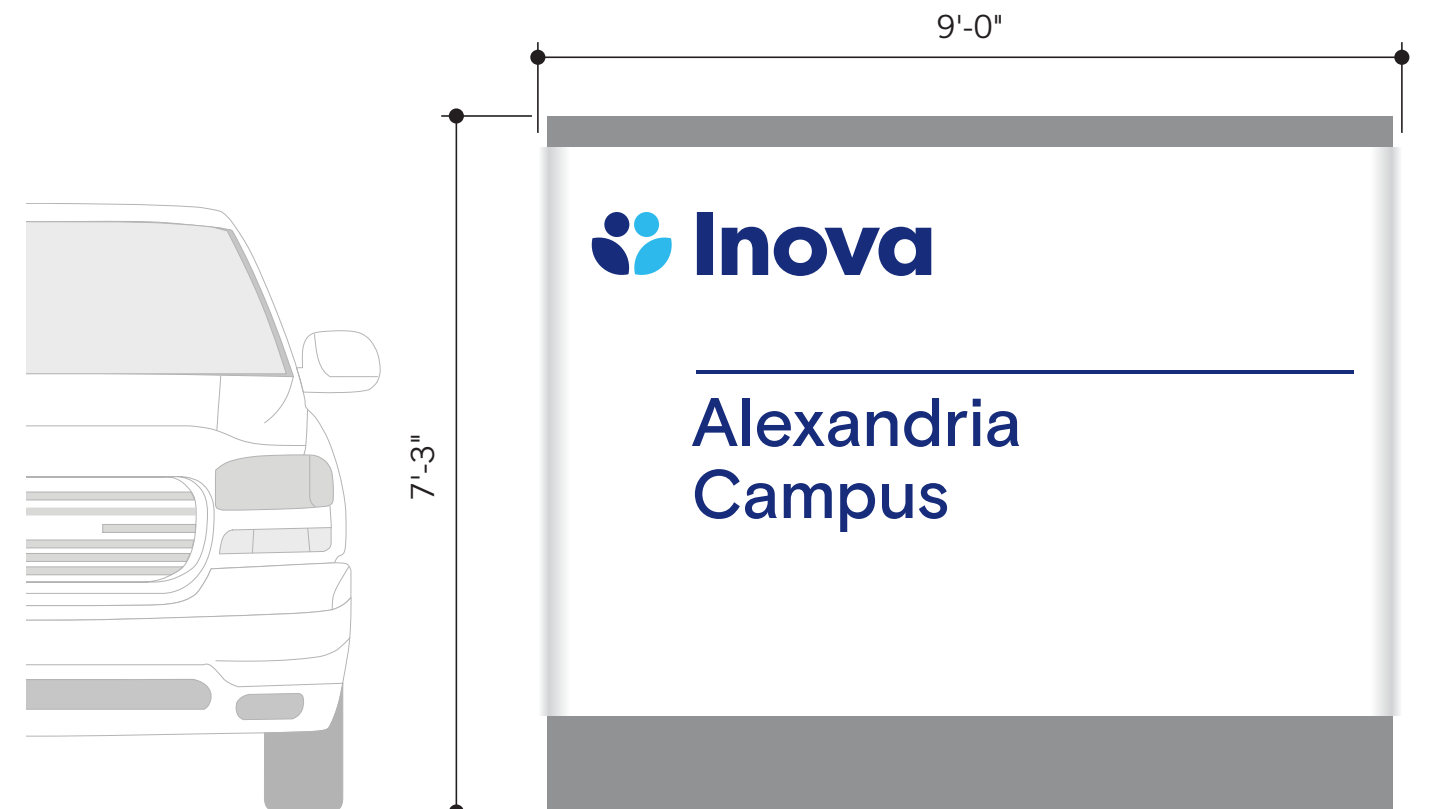

A4.2 - BUILDING ID, LETTERS

QTY: 3

Dimensional letters with illuminated faces identify the entrances of different buildings throughout the Hospital campus. These are mounted in a typical fashion on the metal headers over the doors at each main entrance vestibule in order to confirm that the user has reached the correct building for their destination.

Design Specifications

- Dimensions: 21'-9"w x 1'-2"h, Sign Area: 29 sqft. (accommodates varying messages)
- Internally illuminated LED Channel Letters with painted gray metal returns, light gray faces during day and illuminated white faces at night.
- Face of letters sit 1 1/2-inches proud of building facade.

Sign messages shown on elevation for design intent only. Final content TBD.

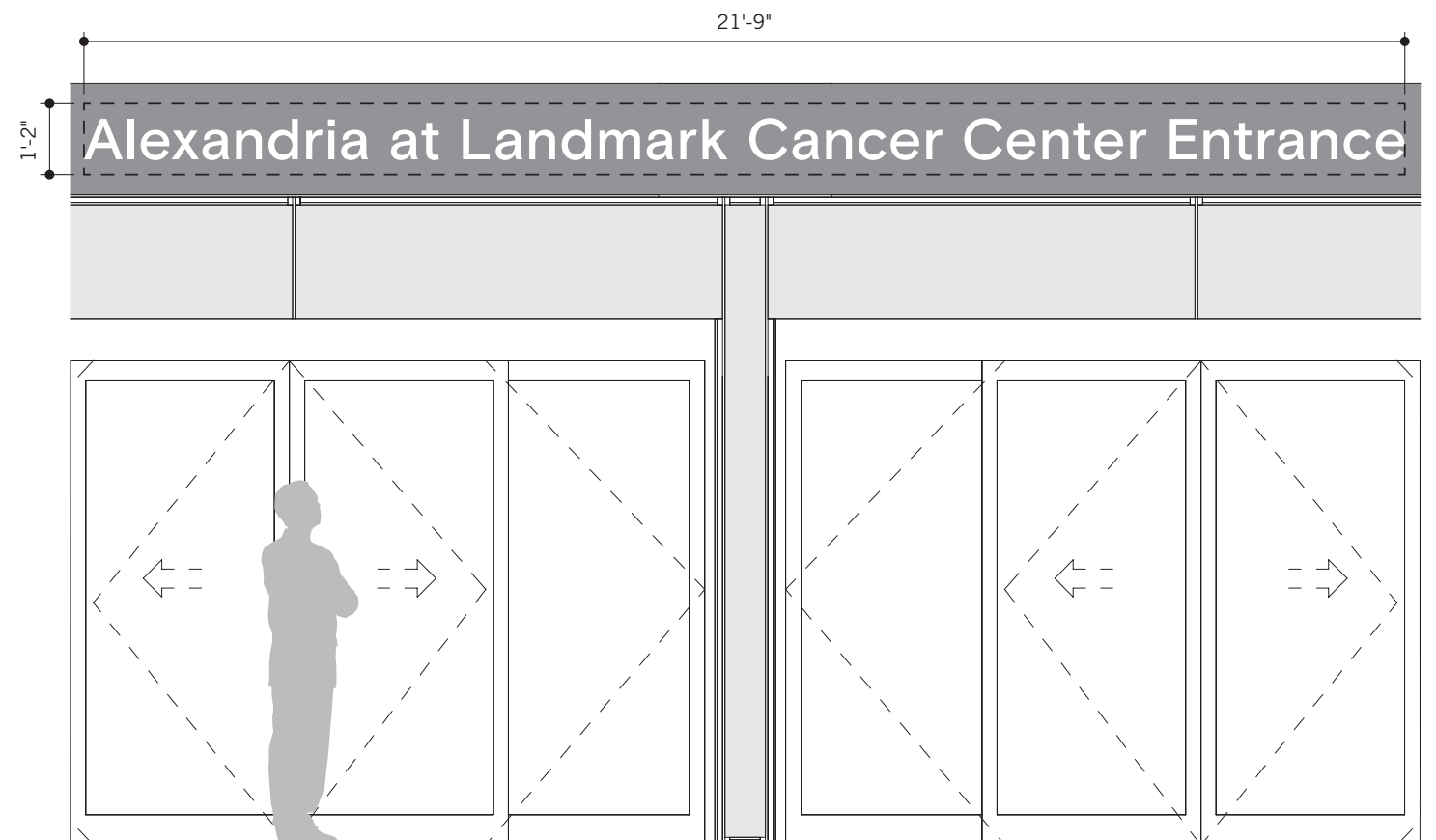
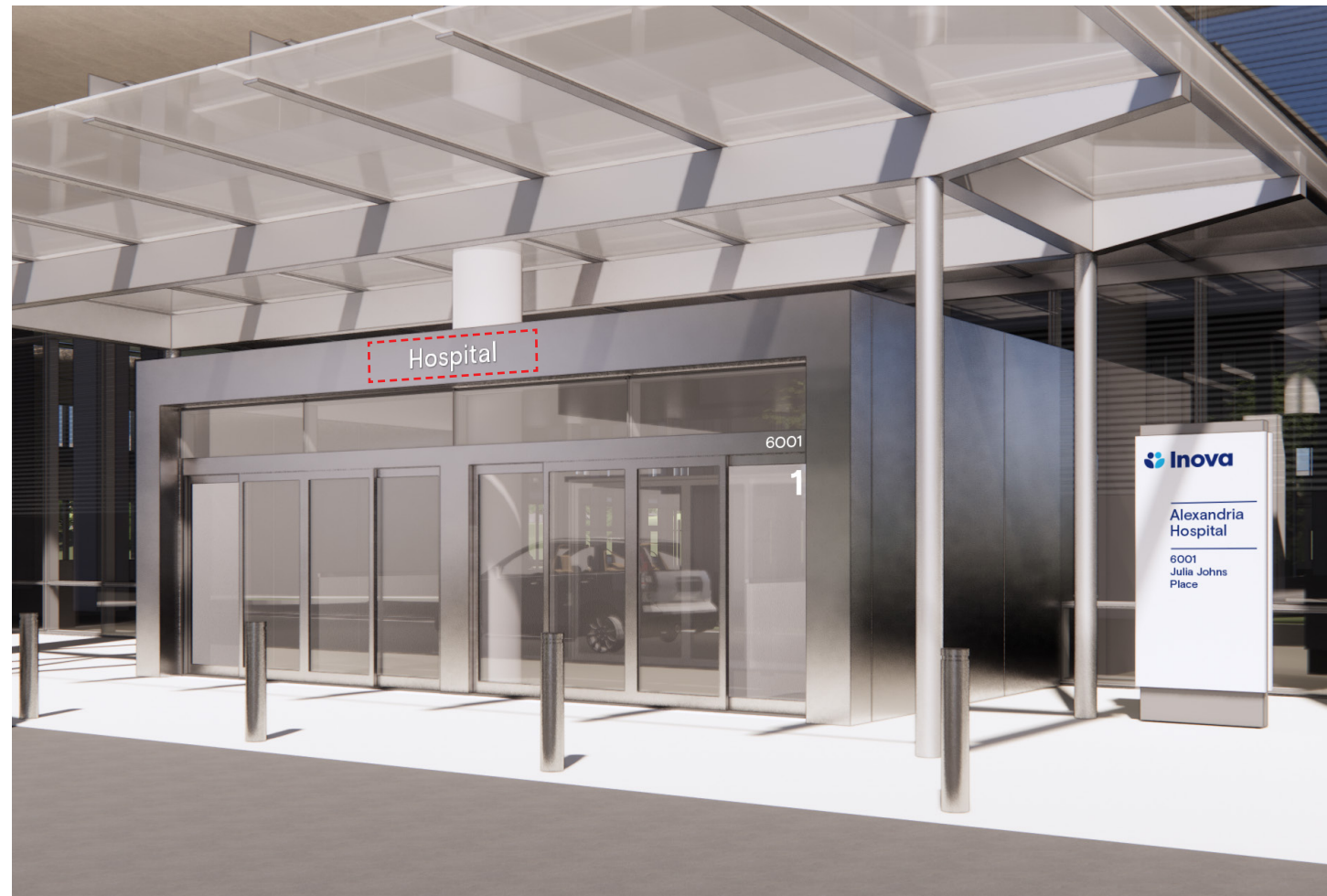

A5.2 - EMERGENCY BUILDING ID, LETTERS

QTY: 2

Elevated dimensional letters with red illuminated faces identify entrances designated exclusively for Ambulance drivers.

This sign is scaled smaller than the Emergency entrance signs intended for the public, but the color and illumination are intentional to alert users to the exclusive nature of this entrance.

Design Specifications

- Dimensions: 7'-7" w x 11" h, Sign Area: 6.95 sqft. (accommodates varying messages)
- Internally illuminated LED Channel Letters with painted gray metal returns, red faces during day and illuminated red faces at night.
- Face of letters sit 1 1/2-inches proud of building facade.

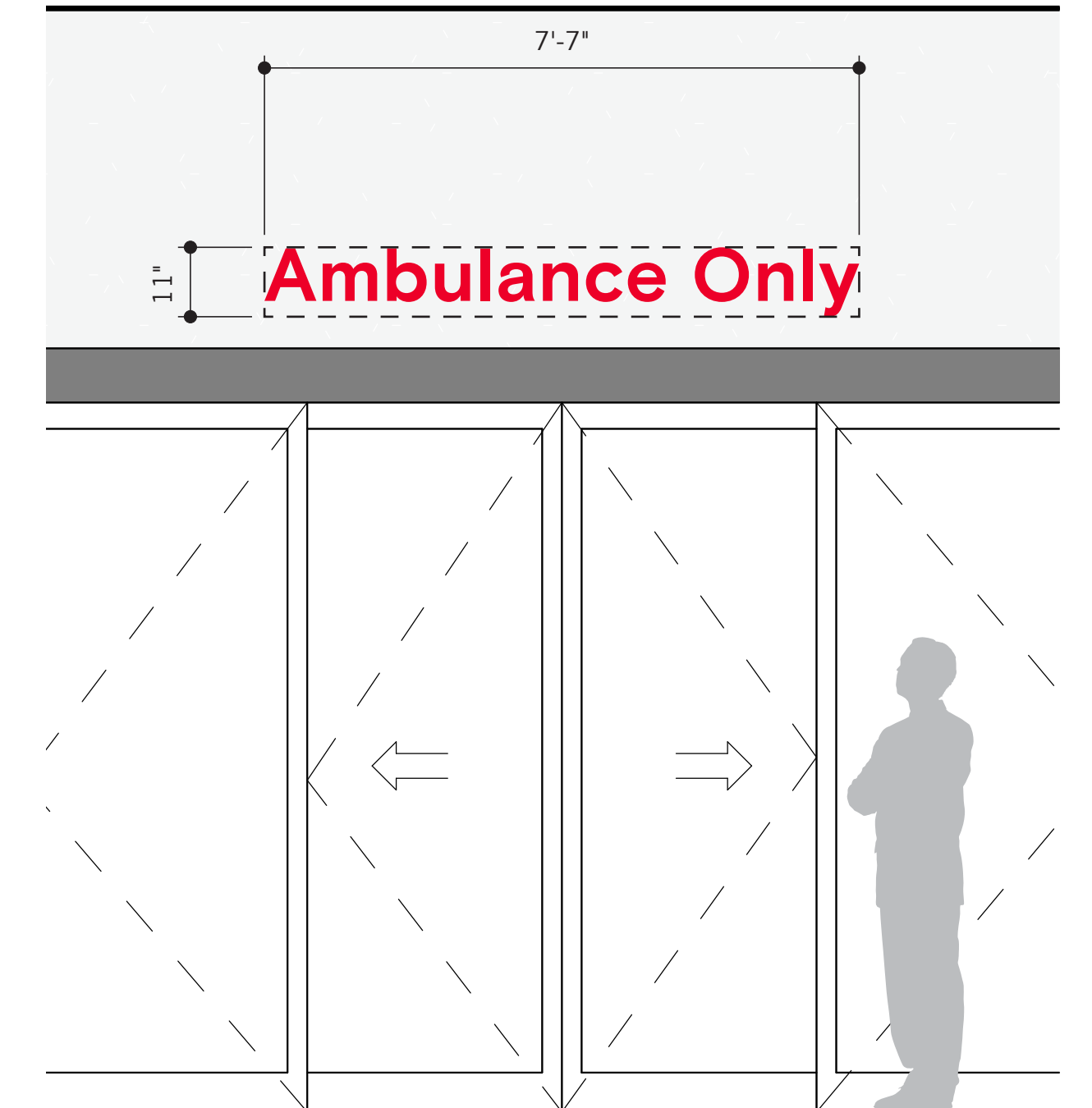

A5.4 - EMERGENCY BUILDING ID, CANOPY LETTERS

QTY: 1

Internally illuminated channel letters are attached to the front of the canopy over the Emergency entrance to the Inova Hospital at Landmark.

The elevated height and increased size are necessary for visibility from a further distance as the public-facing emergency entrance is designed largely for vehicular drop off.

Design Specifications

- Dimensions: 10'-1" w x 1'-9" h, Sign Area: 17.65 sqft.
- Internally illuminated LED Channel Letters with painted gray metal returns and red illuminated faces 24/7 365 days a year.
- Face of letters sit 2-inches proud of canopy fascia

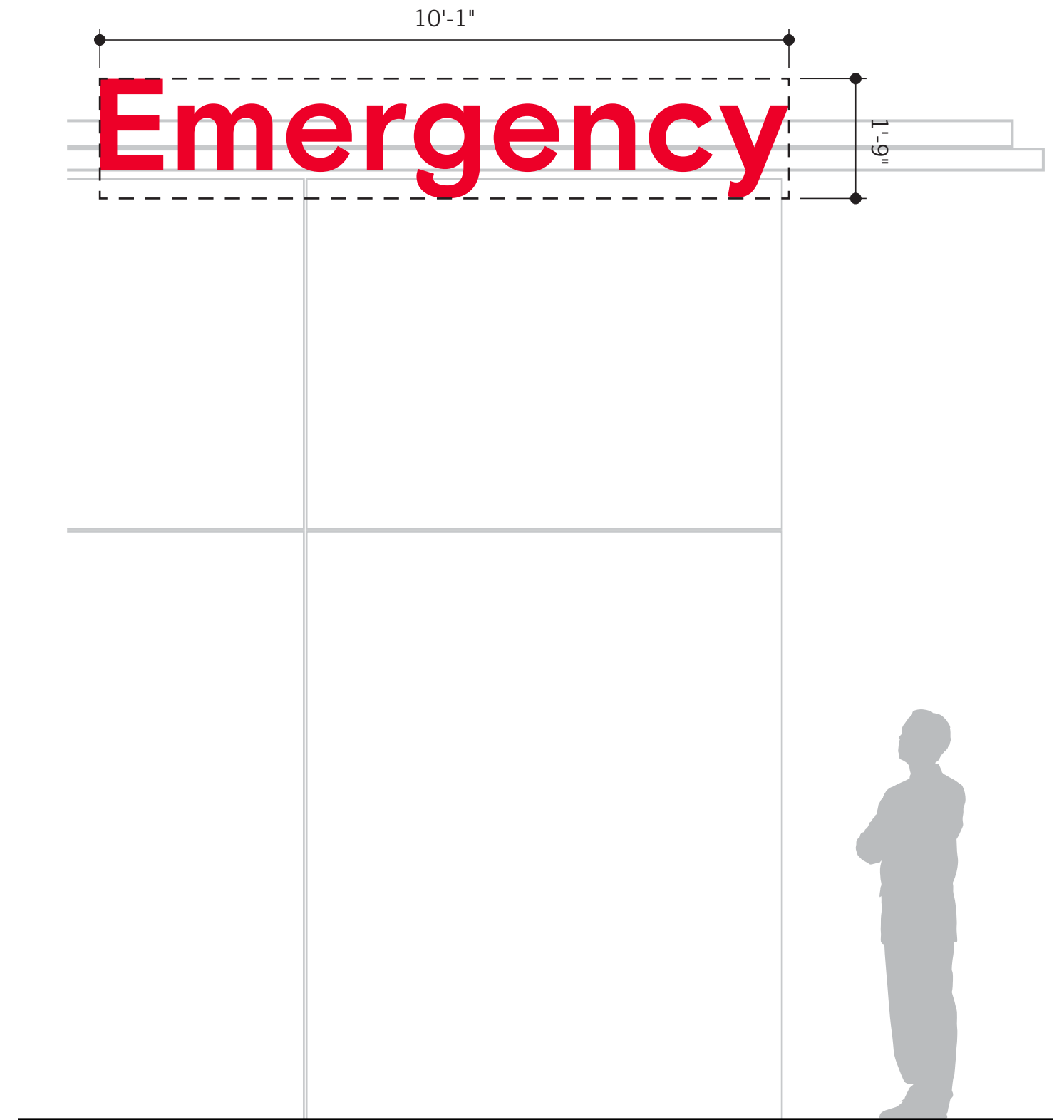

A6.1 - BUILDING ID, FREESTANDING

QTY: 4

Freestanding signs that identify the main entrances to each building within the Hospital campus: this sign is positioned adjacent to each main entrance vestibule to confirm that the user has reached the correct facility for their desired destination.

Design Specifications

- Dimensions: 3'-8" w x 8'-8" h, Sign Area: 33.9 sqft.
- Double-sided free-standing sign with halo-lit painted metal sign panels applied to front and back sides of concrete sign core.
- External in-ground uplighting to illuminate graphics on sign panel(s).

Sign messages shown on elevation for design intent only. Final content TBD.



A8.1 - SECONDARY BUILDING ENTRANCE ID

QTY: 4

Surface mounted vinyl messages at secondary entrances including specific site and building information.

Design Specifications

- Dimensions: 3'-2"w x 3'-4"h, Sign Area: 10.56 sqft.
- Surface-mounted heavy-duty exterior grade vinyl

Sign messages shown on elevation for design intent only. Final content TBD.



A10.1 - BUILDING ADDRESS ID

QTY: 4

Address numerals 4" tall are required by state code to be displayed at the entrance to each building. The typical mounting location for this sign is right-aligned at the metal transom over entrance doors. The alignment and positioning for this sign should be considered with the large entrance number, a separate sign required by Fire Code and applied at the glass door below the address numerals.

Design Specifications

- Dimensions: 1'-3"w x 4"h, Sign Area: 0.5 sqft. (accommodates varying messages)
- 1/2" thick aluminum characters mounted to transom

Sign messages shown on elevation for design intent only. Final content TBD.

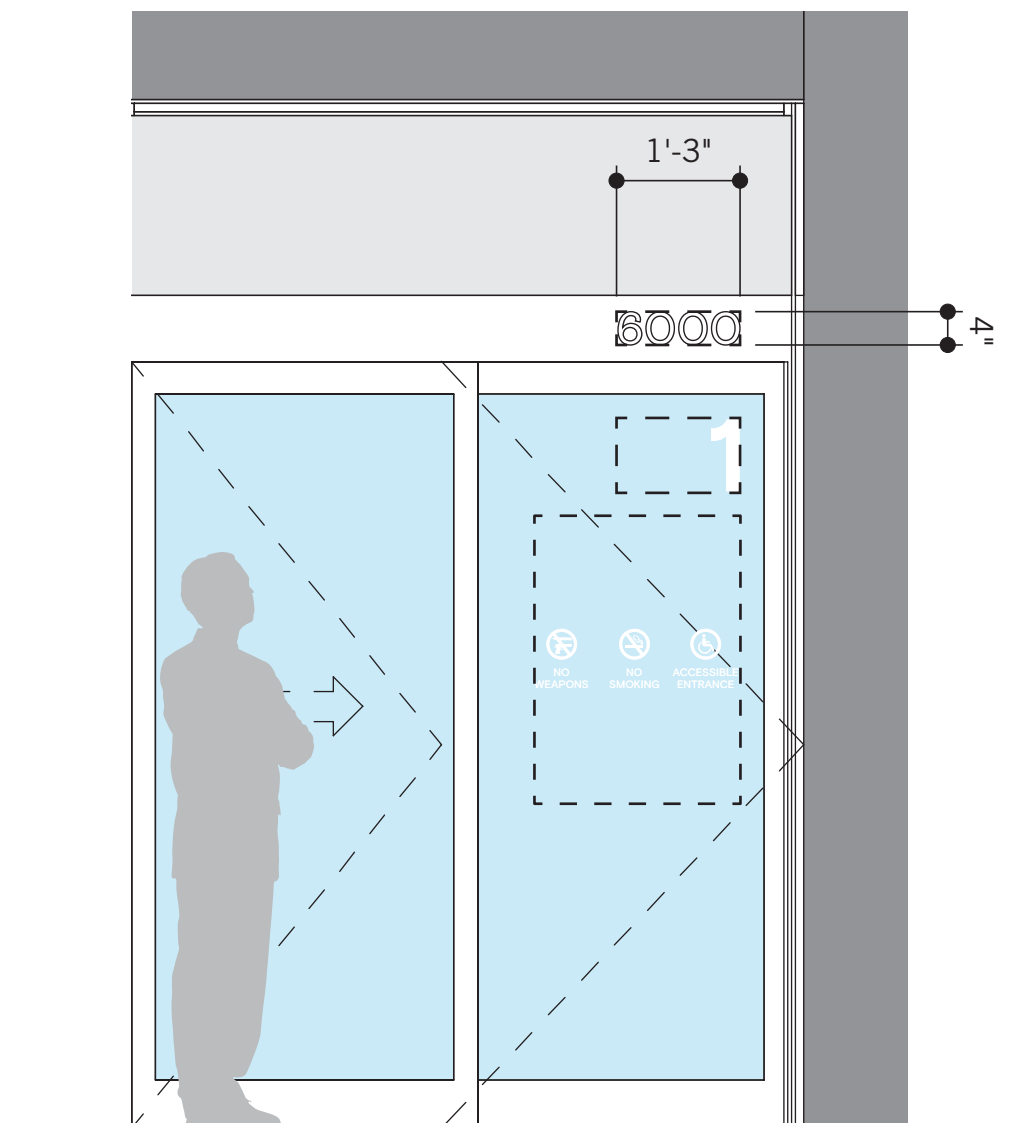

A11.1 - BUILDING ENTRANCE NUMBER

QTY: 27

These 9 inch high cut vinyl letters are required by Fire Code to identify different door entrances for rapid response vehicles in the case of an emergency.

Design Specifications

- Dimensions: 1'-4"w x 9"h,
Sign Area: 1 sqft. (accommodates varying messages)
- First surface applied vinyl messaging installed on glass at entry or on each entrance/exit door



Reference photo of existing building entrance

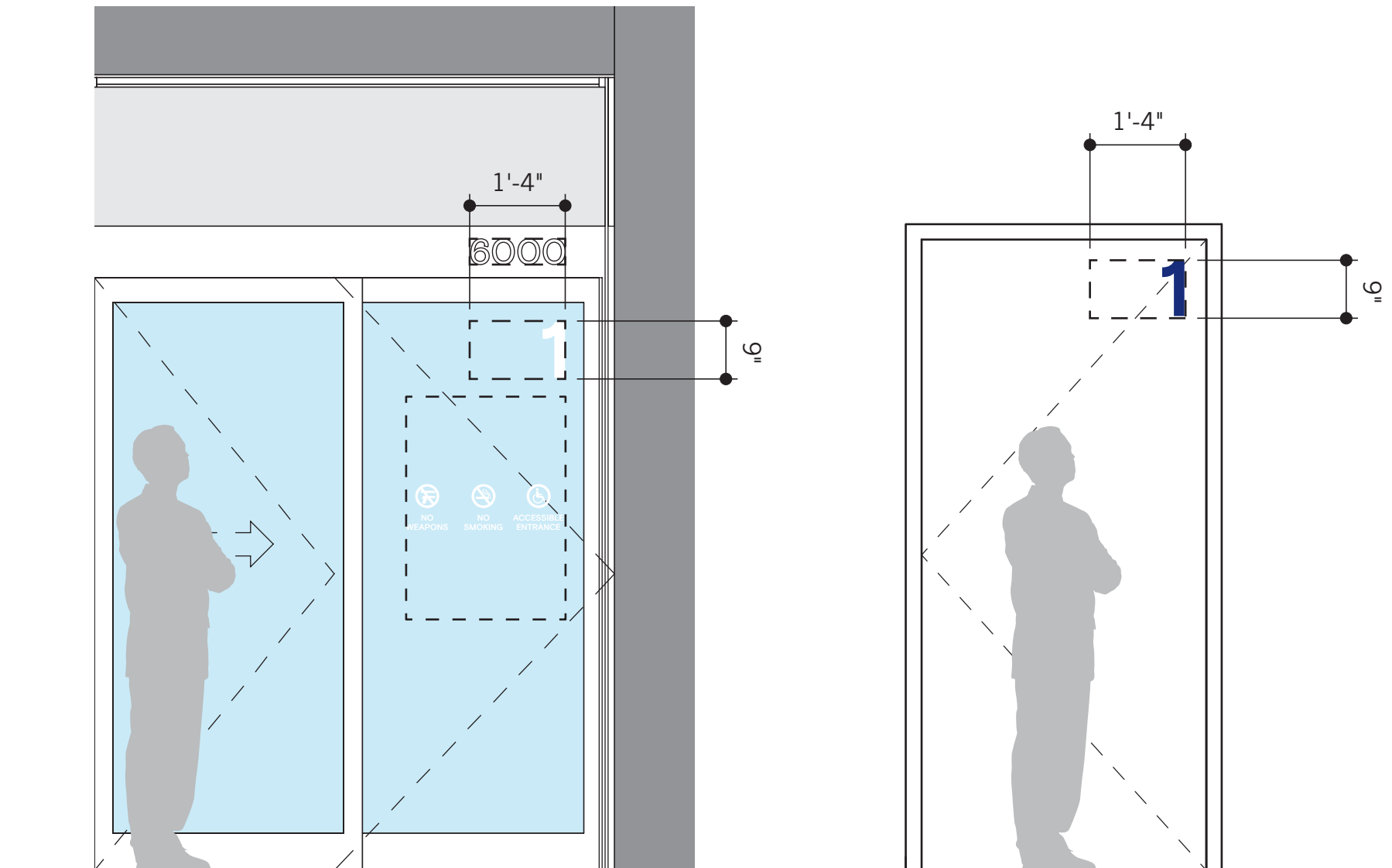

Sign messages shown on elevation for design intent only. Final content TBD.

A12.1 - PARK ID, FREESTANDING

QTY: 1

This ground mounted free-standing sign provides information guided by the City of Alexandria related to the publicly accessible exterior spaces that help make the site amenable to pedestrians. This information includes park hours, rules, regulations, and emergency contact information. It may also provide information about the flora and fauna found on the site or describe elements of sustainable design undertaken by the site developer.

Design Specifications

- Dimensions: 1'-3" w x 4'-0" h, Sign Area: 6.25 sqft.
- Double-sided free-standing sign with halo-lit painted metal sign panels applied to front and back sides of concrete sign core. Sign panel faces are non-illuminated.
- External ambient lighting to illuminate graphics on sign panels.

Sign messages shown on elevation for design intent only. Final content TBD.

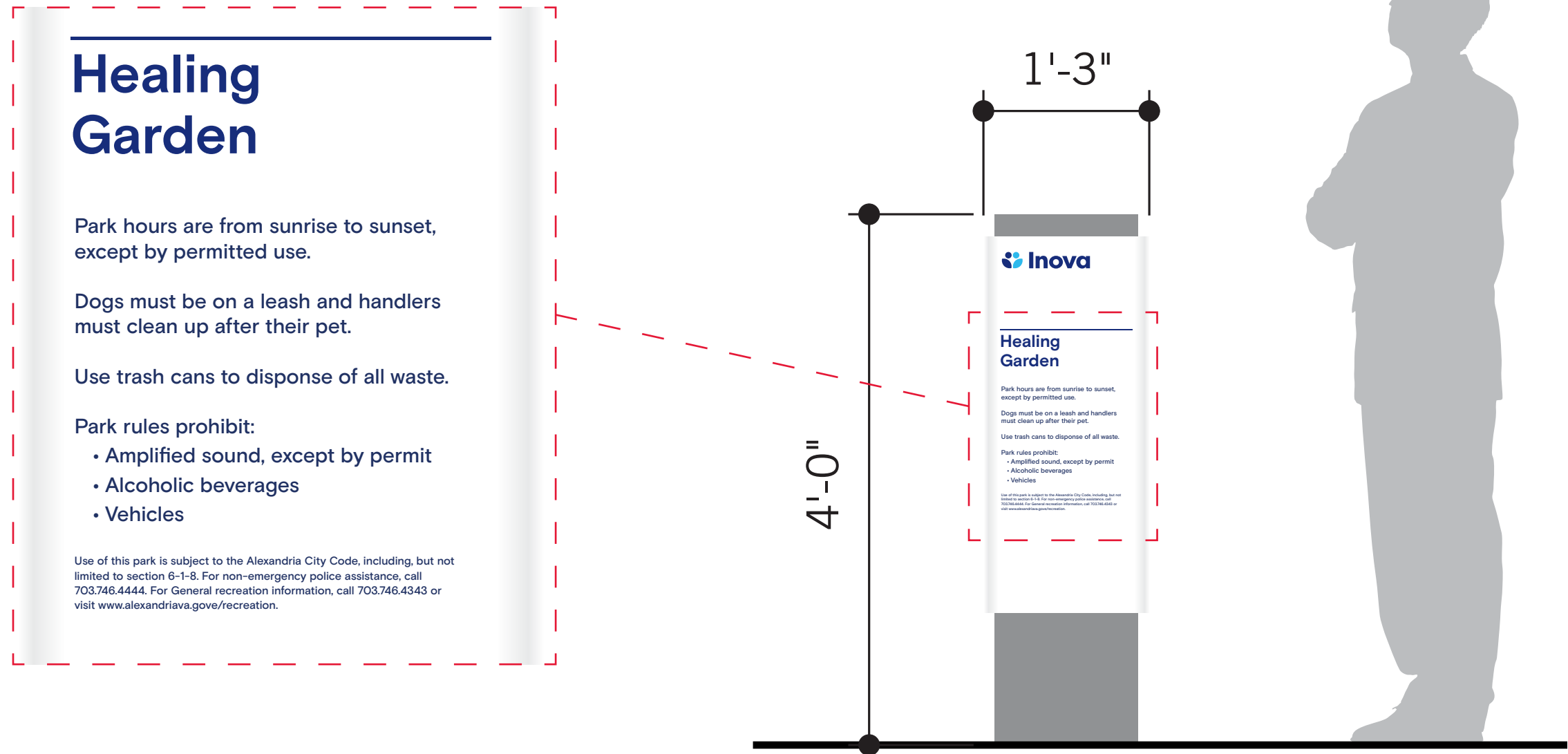

A12.2 - PARK ID, NON-REGULATORY FREESTANDING

QTY: 6

This ground mounted free-standing sign identifies outdoor spaces. It may provide information about the flora and fauna found on the site or describe elements of sustainable design undertaken by the site developer.

Design Specifications

- Dimensions: 1'-3" w x 4'-0" h, Sign Area: 6.25 sqft.
- Double-sided free-standing sign with halo-lit painted metal sign panels applied to front and back sides of concrete sign core. Sign panel faces are non-illuminated.
- External ambient lighting to illuminate graphics on sign panels.

Sign messages shown on elevation for design intent only. Final content TBD.

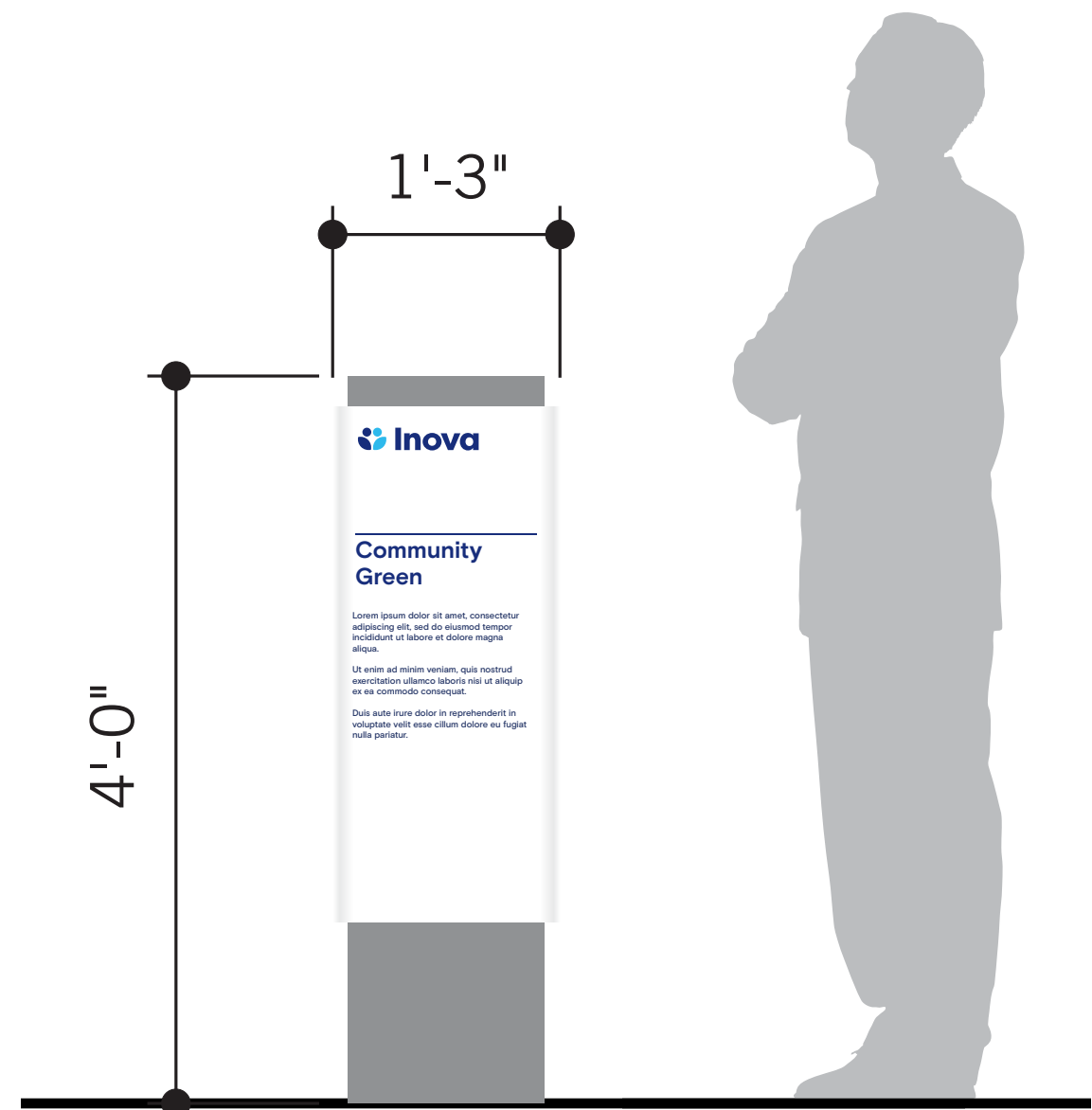

A16.1 - PARKING ID, DIGITAL

QTY: 2

Freestanding sign that identifies different parking garage entrances within the Hospital campus. This sign is positioned at the approach to each garage entrance as part of the driver journey. Arrival is confirmed with building mounted letters (Sign A18.1) placed over the garage entrance portal. The digital display component informs the approaching driver of the availability of parking within the garage.

Design Specifications

- Dimensions: 3'-8" w x 8'-8" h, Sign Area: 33.9 sqft.
- Double-sided free-standing sign with halo-lit sign panels applied to front and back sides of structural sign core.
- External in-ground uplighting to illuminate graphics on sign panel(s)
- Digital display indicating the status of the parking garage

Sign messages shown on elevation for design intent only. Final content TBD.

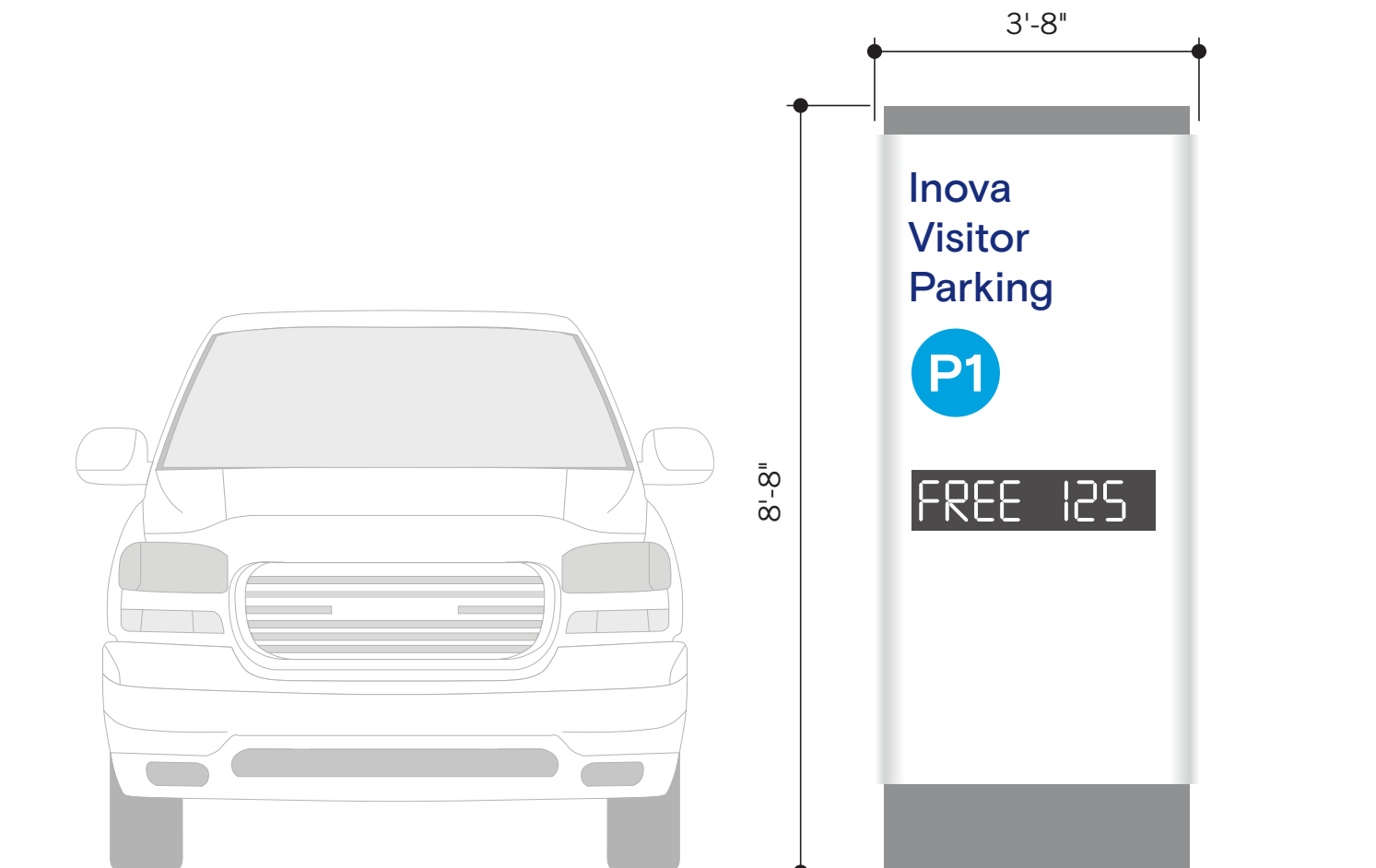

A16.2 - PARKING ID, DIGITAL / DIRECTIONAL

QTY: 1

A hybrid freestanding sign that identifies Hospital campus parking garage entrances and provides directional information to help support and facilitate driver decision making along the major campus thoroughfare. This sign is positioned at the approach to a garage entrance as part of the driver journey. Arrival is confirmed with building mounted letters (Sign A18.1) placed over the garage entrance portal. The digital display component informs the approaching driver of the availability of parking within the garage.

Design Specifications

- Dimensions: 5'-0"w x 11'-9"h, Sign Area: 58.75 sqft.
- Double-sided free-standing sign with halo-lit sign panels applied to front and back sides of structural sign core.
- External in-ground uplighting to illuminate graphics on sign panel(s)
- Digital display indicating the status of the parking garage

Sign messages shown on elevation for design intent only. Final content TBD.

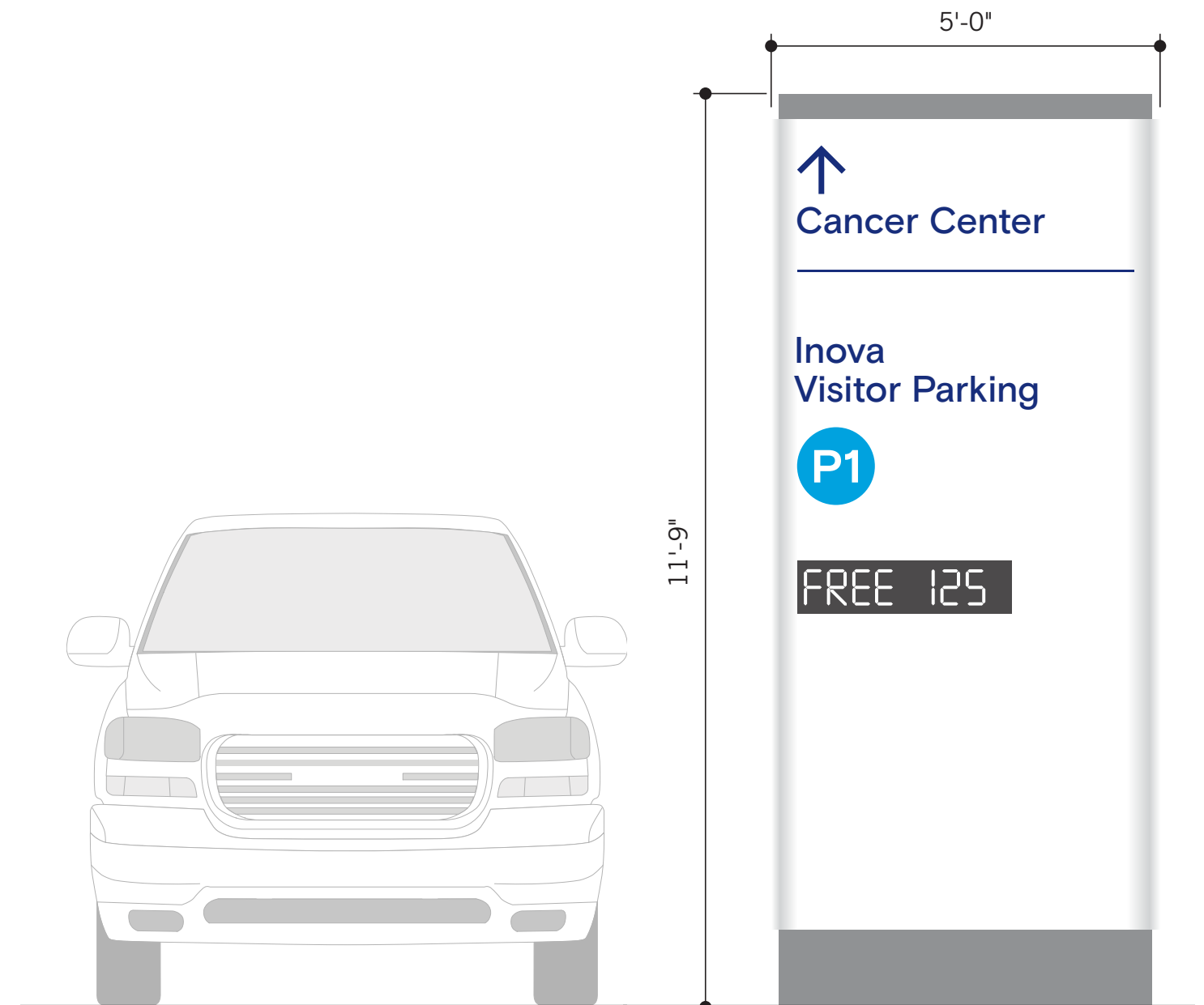

A18.1 - PARKING ID, LETTERS

QTY: 4

Elevated dimensional letters with blue illuminated faces are mounted to the building facade over the public entrance portals to the parking garage.

Supplementary entrance, exit, and height clearance information is supplied by additional signage below as required to regulate circulation at the garage portals.

Design Specifications

- Dimensions: 12'-11" w x 1'-5" h, Sign Area: 18.45 sqft. (accommodates varying messages)
- Internally illuminated LED Channel Letters with painted gray metal returns, blue faces during day and illuminated white faces at night.

Sign messages shown on elevation for design intent only. Final content TBD.

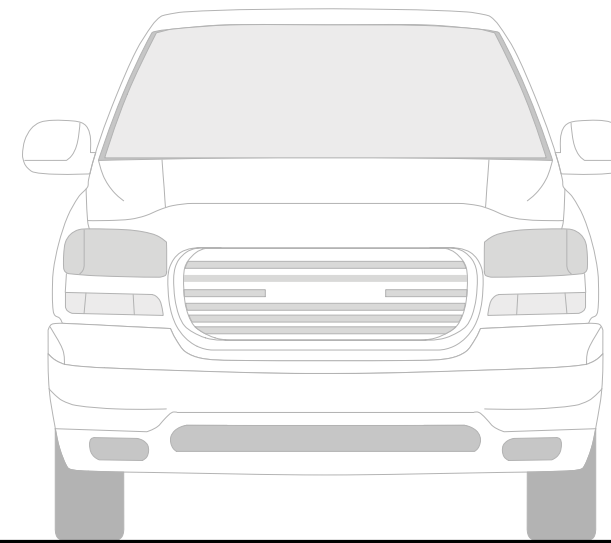

A18.2 - PARKING ENTRANCE / EXIT, LETTERS

QTY: 4

Entrance and exit information is mounted as smaller dimensional letters under the garage identification letters, directly over the portal, in order to regulate circulation in and out of the parking garages.

Design Specifications

- Dimensions: 6'-9"w x 11"h, 2'-3"w x 11"h
Sign Area: 9.45 sqft. (accommodates varying messages)
- Internally illuminated LED Channel Letters with painted gray metal returns, black faces during day and illuminated white faces at night.

Sign messages shown on elevation for design intent only. Final content TBD.

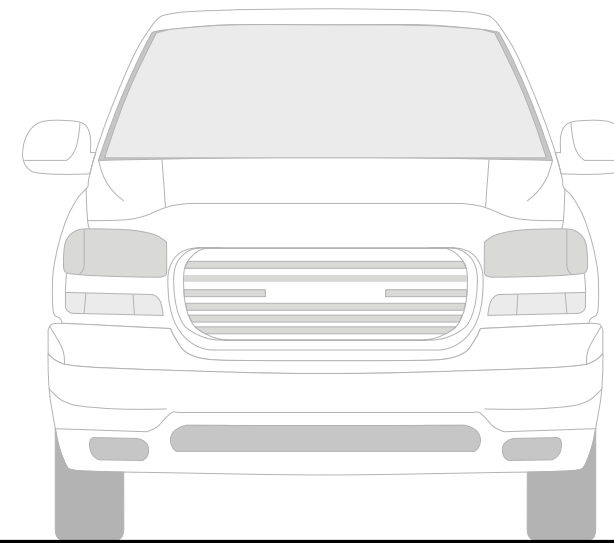
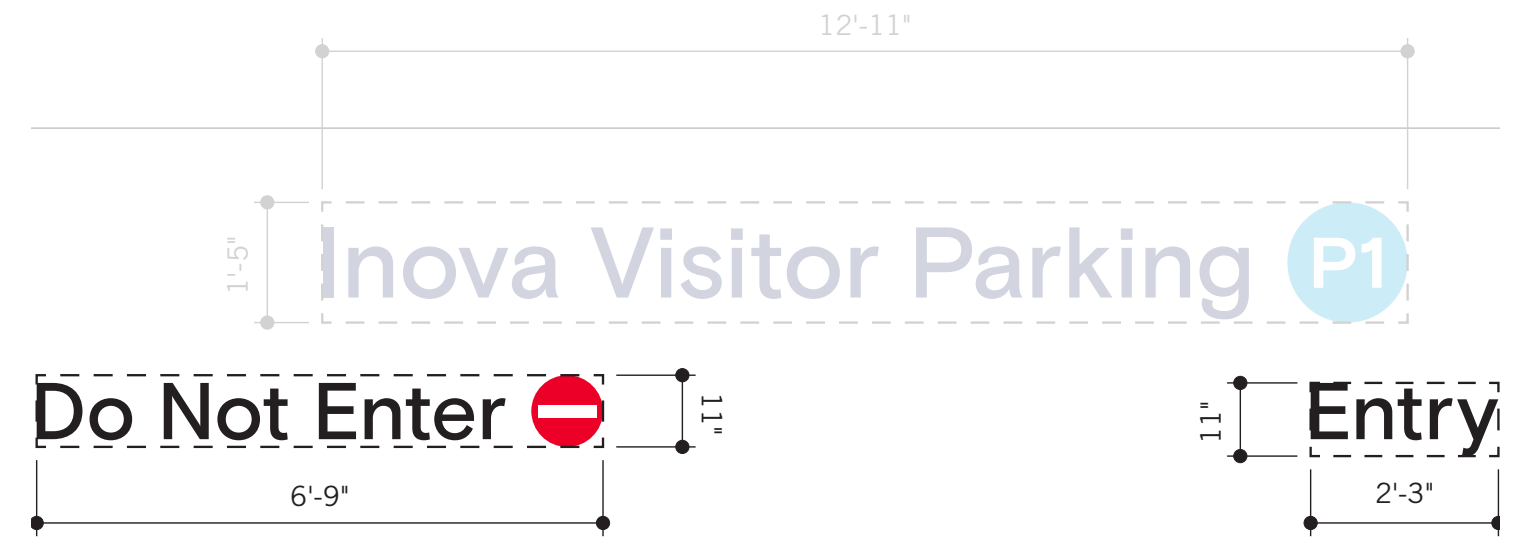

B1.1 - VEHICULAR DIRECTIONAL, FREESTANDING

QTY: 7

Directional free-standing signs are located at major intersections, particularly along Julia Johns Place, to direct vehicular traffic to prominent parking and building entrance drop-off locations. This sign is intended to help support and facilitate driver decision making along the major campus thoroughfare.

Design Specifications

- Dimensions: 5'-0"w x 11'-9"h, Sign Area: 58.75 sqft.
- Double-sided free-standing sign with halo-lit painted metal sign panels applied to front and back sides of concrete sign core.
- External in-ground uplighting to illuminate graphics on sign panel(s)

Sign messages shown on elevation for design intent only. Final content TBD.

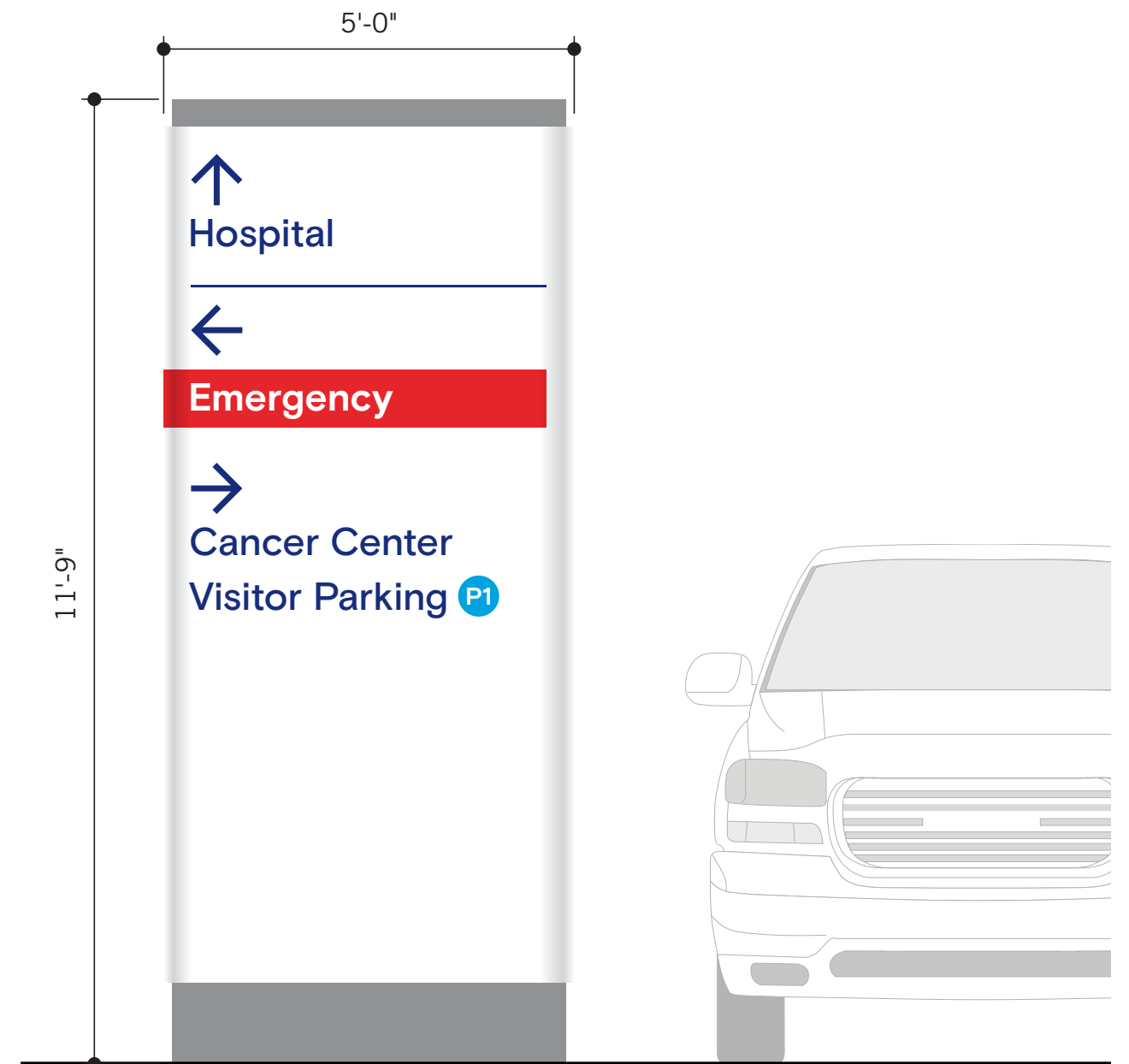

B1.2 - VEHICULAR DIRECTIONAL, FREESTANDING

QTY: 6

Smaller scale directional free-standing sign located at Tucker Place and at the perimeter of the Hospital. The reduced size of this sign is more appropriate for the denser intersections and throughways where traffic will be moving slower and the directional signs should not compete with adjacent identification signs.

Design Specifications

- Dimensions: 4'-0"w x 9'-3"h, Sign Area: 37 sqft.
- Double-sided free-standing sign with halo-lit painted metal sign panels applied to front and back sides of concrete sign core.
- External in-ground uplighting to illuminate graphics on sign panel(s)

Sign messages shown on elevation for design intent only. Final content TBD.

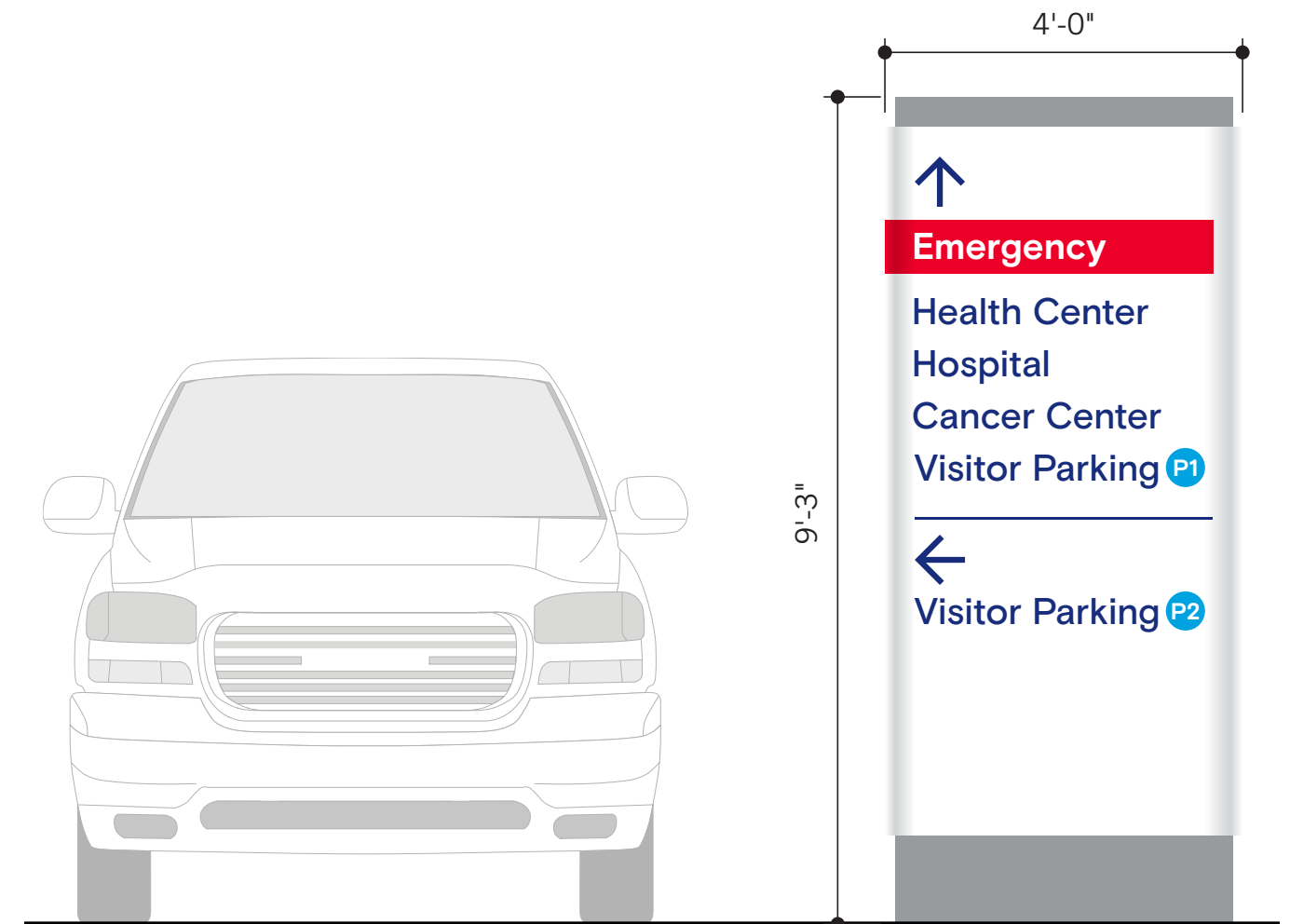

B1.3 - VEHICULAR DIRECTIONAL, FREESTANDING

QTY: 1

A small scale directional free-standing sign located along West End Boulevard. With only a single message to deliver, the smaller size of this sign is adequately suited for delivering directional information without appearing too prominent within its environment. This sign is situated close to the road with an unobstructed view for motorists.

Design Specifications

- Dimensions: 1'-0" w x 1'-7 1/2" h, Sign Area: 8.13 sqft.
- Double-sided free-standing sign with halo-lit painted metal sign panels applied to front and back sides of concrete sign core.
- External in-ground uplighting to illuminate graphics on sign panel(s)

Sign messages shown on elevation for design intent only. Final content TBD.

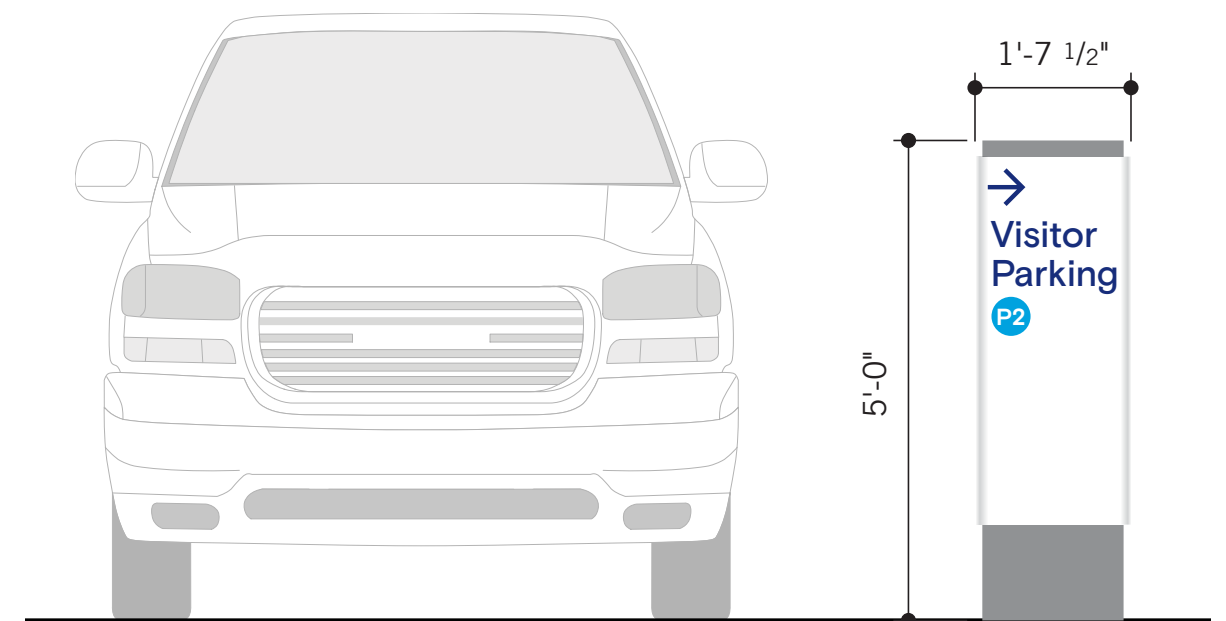

B1.4 - VEHICULAR DIRECTIONAL, FREESTANDING (ALT)

QTY: 8

This vehicular movement control sign is placed only at locations where public traffic must be directed away from a paved vehicular path.

Design Specifications

- Dimensions: 2'-8" w x 8'-8" h, Sign Area: 23.11 sqft.
- Double-sided free-standing sign with halo-lit painted metal sign panels applied to front and back sides of concrete sign core.
- External in-ground uplighting to illuminate graphics on sign panel(s)

Sign messages shown on elevation for design intent only. Final content TBD.

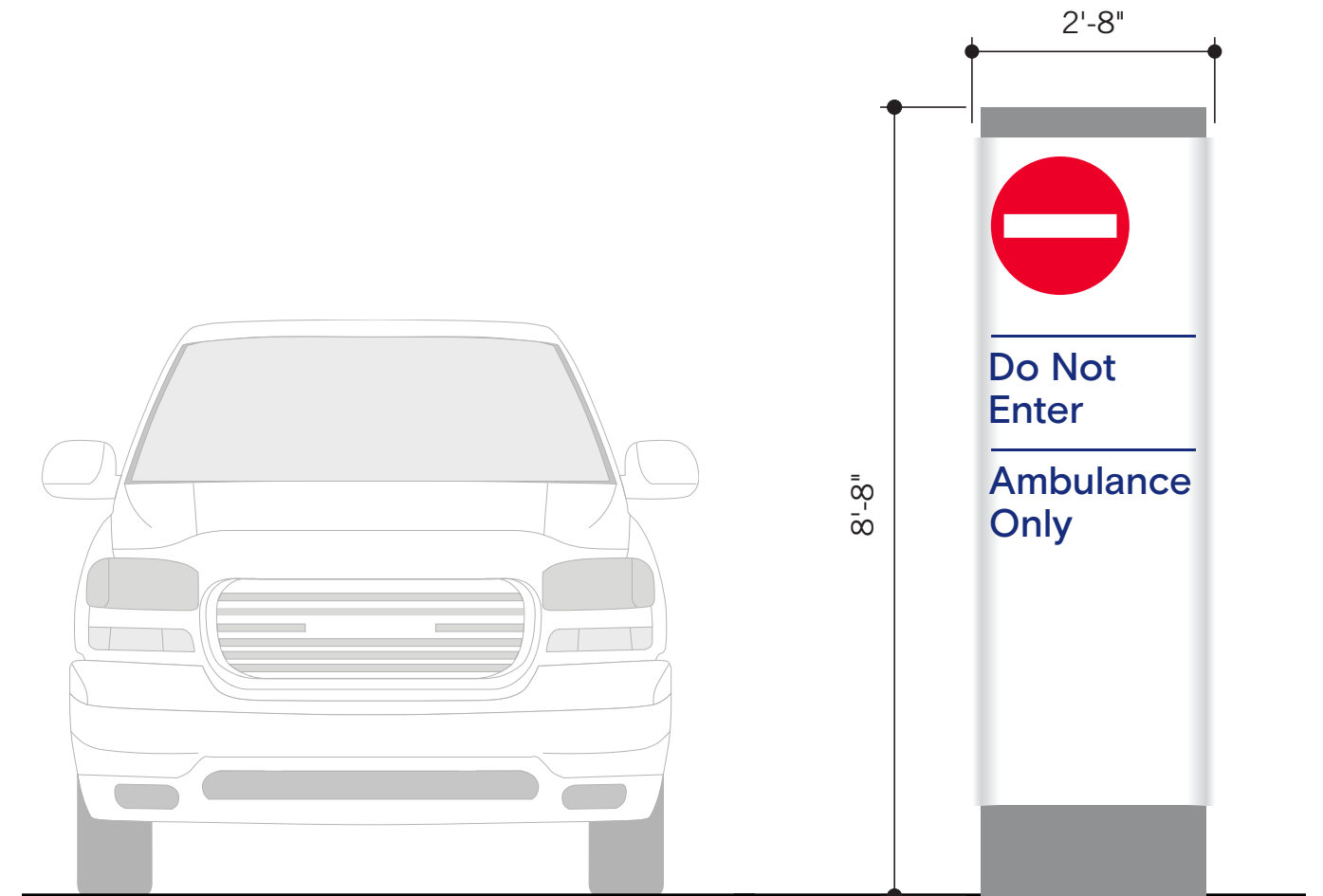

B2.1 - PEDESTRIAN DIRECTIONAL & MAP, FREESTANDING

QTY: 11

Pedestrian scale directional free-standing signs are located at major intersections to aid visitors in navigating the multi-building Hospital campus. More information is able to be provided at eye level to pedestrians who can orient themselves through directional information or directory maps.

Design Specifications

- Dimensions: 1'-3"w x 6'-0"h, Sign Area: 7.5 sq.
- Double-sided free-standing sign with halo-lit painted metal sign panels applied to front and back sides of concrete sign core.
- External ambient lighting to illuminate graphics on sign panels.

Sign messages shown on elevation for design intent only. Final content TBD.

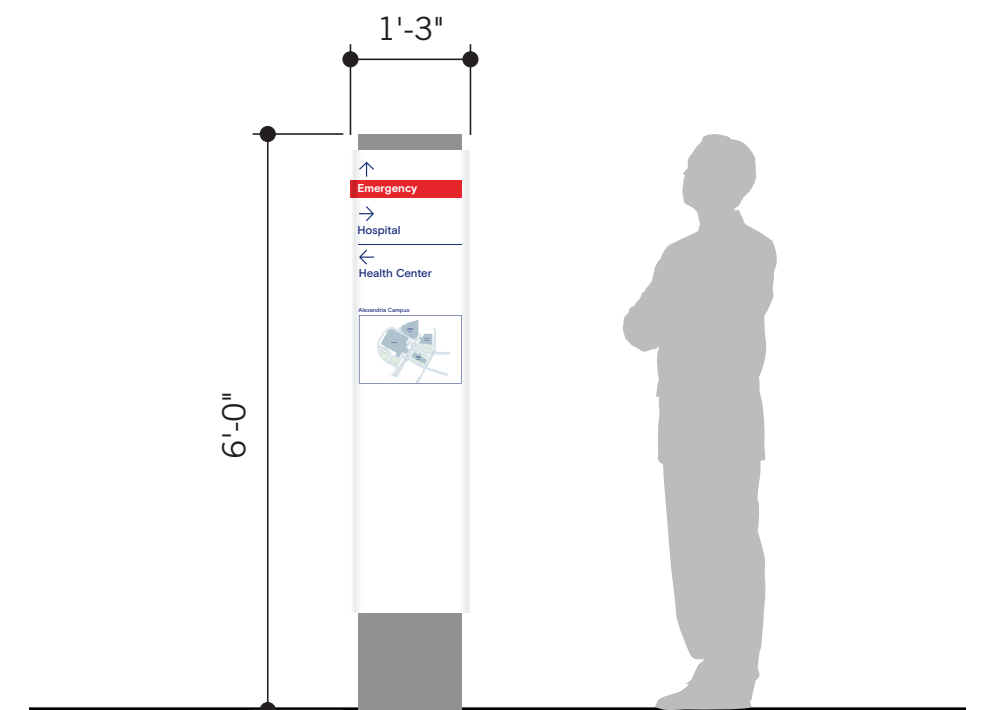

B3.1 - VALET ID / DROP-OFF ID

QTY: 4

Smaller scale freestanding sign is used to designate areas reserved for pick up and drop off in order to regulate circulation on active drive ways.

Design Specifications

- Dimensions: 1'-3"w x 6'-0"h, Sign Area: 7.5 sq.
- Double-sided free-standing sign with halo-lit painted metal sign panels applied to front and back sides of concrete sign core.
- External ambient lighting to illuminate graphics on sign panels.

Sign messages shown on elevation for design intent only. Final content TBD.

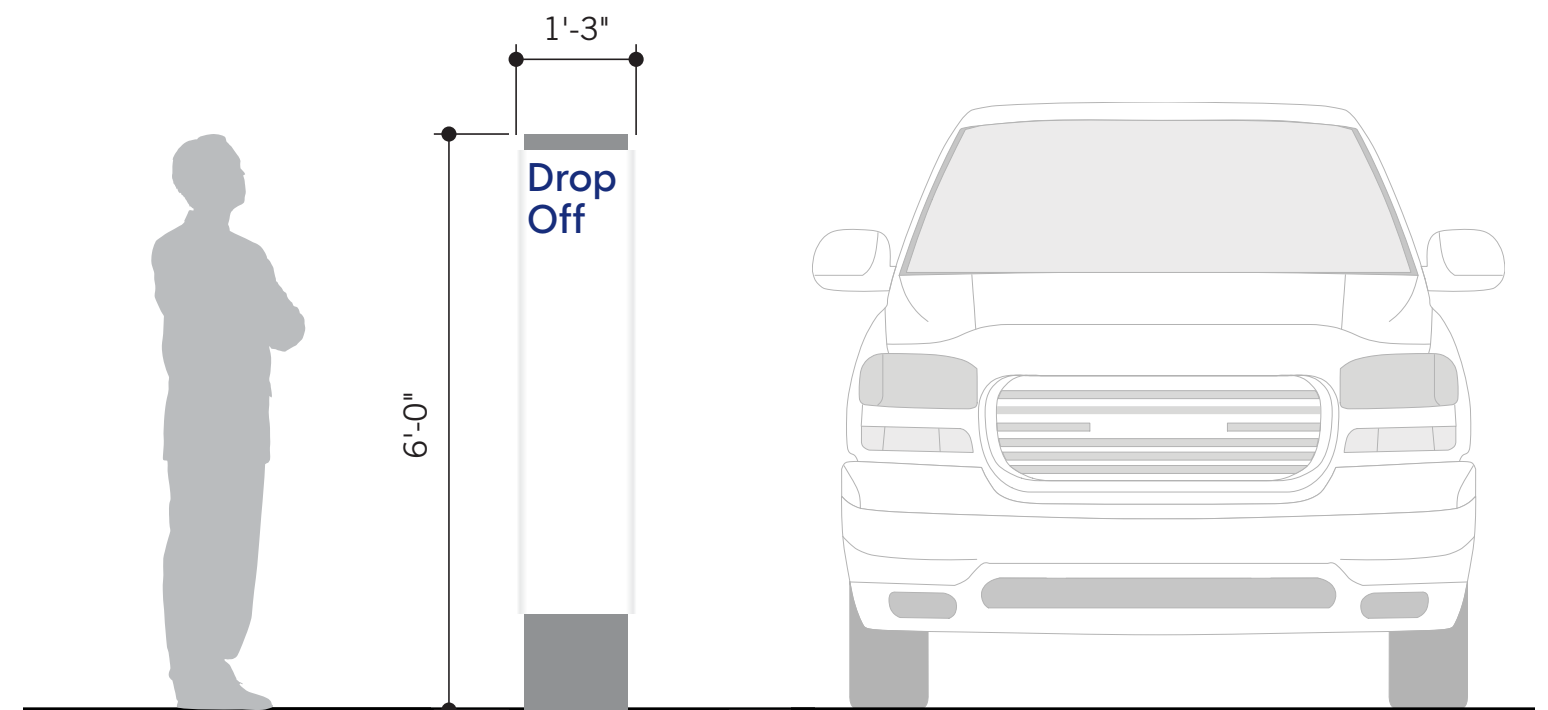

R8.3 - ENTRANCE INFORMATION

QTY: 10

Glass mounted vinyl messages at entrances providing specific site and building information, such as hours of operation, address, visitors policies, or any other required information.

Design Specifications

- Dimensions: 2'-2" w x 3'-0" h, Sign Area: 6.5 sqft.
- Second surface applied reverse cut vinyl messages installed at entrance vestibules

Sign messages shown on elevation for design intent only. Final content TBD.

